



# WX350 Tractor Mount Splitter Parts Manual

S/N 600067 & After



## Foreword

EMB Mfg. has prepared this parts manual to assist customers in ordering quality OEM replacement parts.

Proper and regular service and replacing old, worn or broken parts with the correct OEM parts are essential to prolonging the life of your EMB product. Please refer to this manual before ordering any replacement parts.

All information contained in this parts manual is based on the latest product specification available at the time of printing this manual. If your product differs from the specifications contained within this manual contact EMB Mfg. for information.

EMB reserves the right to alter specifications on their products at any time.

Reproduction of this parts manual of any kind is prohibited without prior written permission from EMB Mfg.

# Table of Contents

Cylinder	5
Main Parts	7
Valve Assembly	8
Valve and Fittings	10
4-Way Wedge (Optional)	11
Decal Breakdown	12

This Page is Intentionally Blank

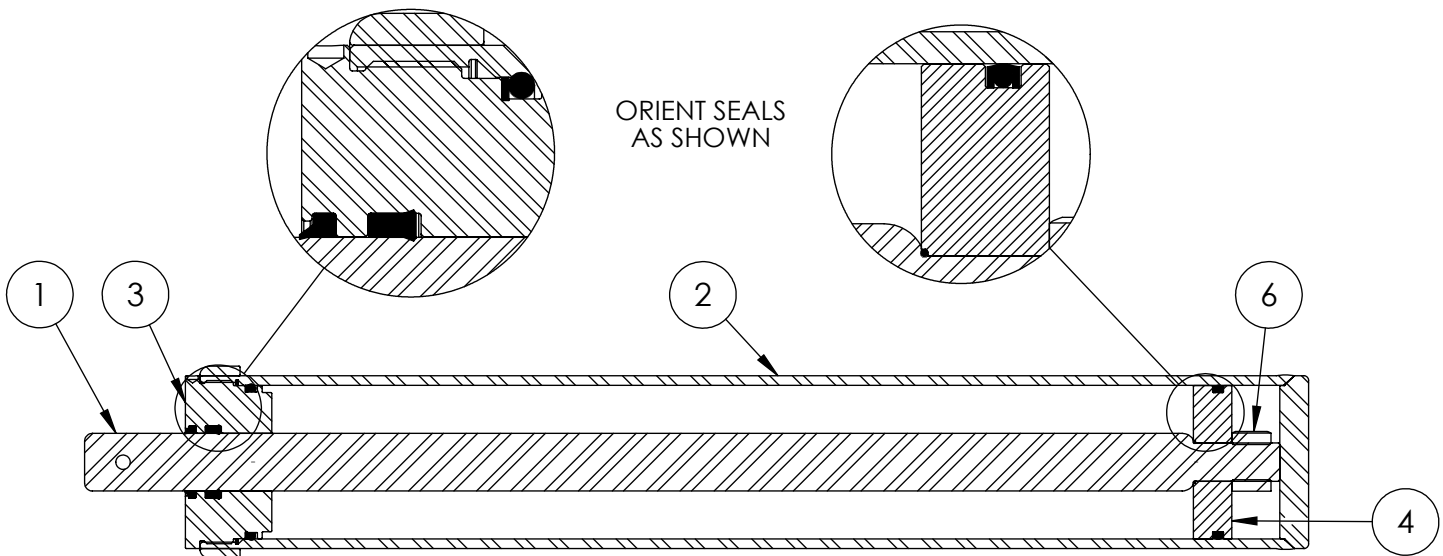

**4" x 24" STROKE CYLINDER PARTS**

ITEM	PART NO.	Description	QTY.
1	2011C1012	Rod, 1-1/2 x 1	1
2	2011C1014	Barrel, 4"	1
3	G400-150SA	4" Bore x 1-1/2" Rod Gland	1
4	P100-400SA	4" Bore Piston	1
5	SLK-4015	Seal Kit, 4 x 1-1/2	1
6	Z72292G8	Hex Lock Nut 1NF Grade 8	1

This Page is Intentionally Blank

Main Parts

BOM ID	Part No.	Description	Qty
1	2011C101	Cylinder, 4 x 24 x 1-1/2	1
2	2014A401	Assembly, Wide Sliding Wedge	1
3	2014S414	Plate, Sliding Wedge Capture	1
4	2014S421	Plate, Cylinder Retaining (Bolt)	1
5	2014W402	Weldment, Sliding Wedge	1
6	2014W403	Lower 3pt Weldment	1
7	2014W405	WX370 H/V Base	1
8	Z51331	Elbow 90, MP x FPX 0808	1
9	Z51926	Quick Coupler, FP08 x M ISO 7241-1	2
10	Z52301	1/2" Hose, MP08 x MP08 x 13"	1
11	Z52305	1/2" Hose, MP08 x MP08 x 21"	1
12	Z52310	1/2" Hose, MP08 x MP08 x 45"	2
13	Z71325	Hex Bolt, 3/8NC x 2-1/2"	1
14	Z71555	Hex Bolt, 1/2NC x 5-1/2"	3
15	Z71576G8	Hex Bolt, 1/2NF x 1-1/2" G8	4
16	Z72231	Hex Lock Nut, 3/8NC	1
17	Z72251	Hex Lock Nut, 1/2NC	7
18	Z76251	Carriage Bolt, 1/2NC x 1-1/2"	4

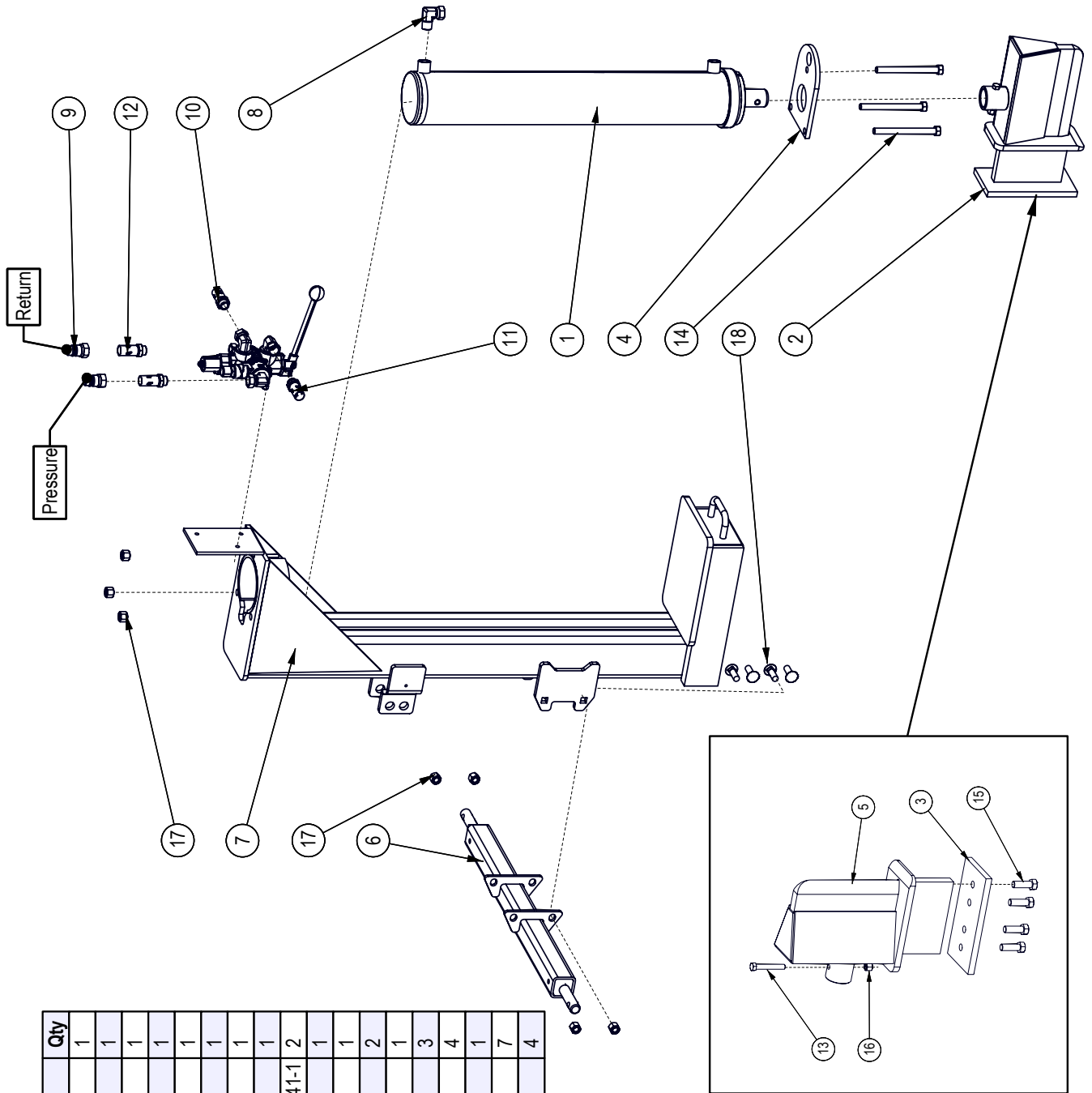

# Valve Assembly

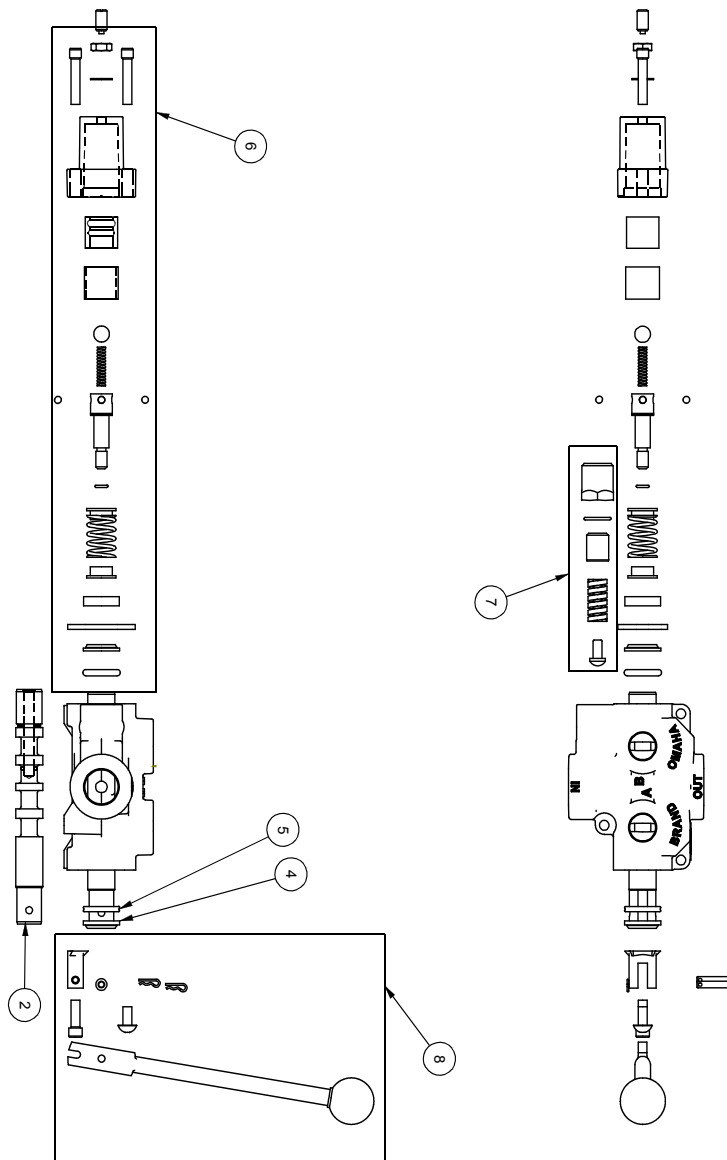

ITEM NO.	QTY.	PART NO.	DESCRIPTION
1	1	AOCASTB	AO CASTING
2	1	LS304T4J	SPOOL
3	1	P1740	NAME TAG
4	1	SF305	WIPER
5	1	SF304	QUAD RING
6	1	SUB4LS	SUB-LS
		B3057	7/16 BALL
		DC7604	3/16 BALL
		SF306	RETAINER
		SF477L	SH LS ENDCAP
		XDC672	LS SLEEVE
		SF483	SPACER
		SF486	ALLEN SCREW
		SF489	CENTER STOP
		SF490	CENTERING SPRING
		SF492	HOUSING
		SF315	SPACER
		LS305	DETENT SPRING
		DC7583	O-RING 3-902
		SF496	O-RING, BLUE, METRIC
		LS306	LS WIPER
		SF902	5/16 LOCK WASHER
		SF903	PLUNGER, SPRING
		SF904	5/16-HEX JAM NUT
		SUB-R	RELIEF
		P1603	CAP NUT
		SF322	O-RING 2-016
		SF364A	ADJ. SCREW
		B505	SPRING
		SF361A	POPET
		Z56915	HANDLE KIT
		SF377	RETAINER
		SF376	SEAL RETAINER
		SF367A	CLEVIS
		SF368	HANDLE
		SF369	PIN
		P1767	PIN CLIP
		HP5	MACH. SCREW
		SF311	KNOB
		SF308	CAP SCREW
		SF303T4J	SPOOL
		P1654	WARNING TAG



ITEM NO.	QTY.	PART NO.	DESCRIPTION
1	1	B5057	7/16 BALL
2	4	DC7604	3/16 BALL
3	1	SF306	RETAINER
4	1	SF477L	SH LS ENDCAP
5	1	SF480	SD SLEEVE
6	1	SF483	SPACER
7	2	SF486	ALLEN SCREW
8	2	SF489	CENTER STOP
9	1	SF490	CENTERING SPRING
10	1	SF492	HOUSING
11	1	SF315	SPACER
12	1	LS305	DETENT SPRING
13	1	DC7583	O-RING 3-902
14	1	SF496	METRIC O-RING
15	1	LS306	LS WIPER
16	1	SF502	5/16 LOCK WASHER
17	1	SF503	SPRING PLUNGER
18	1	SF504	5/16 HEX JAM NUT

Note: This diagram is for reference only. Parts not sold separately.

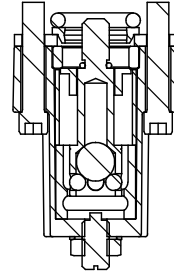
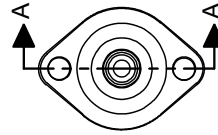
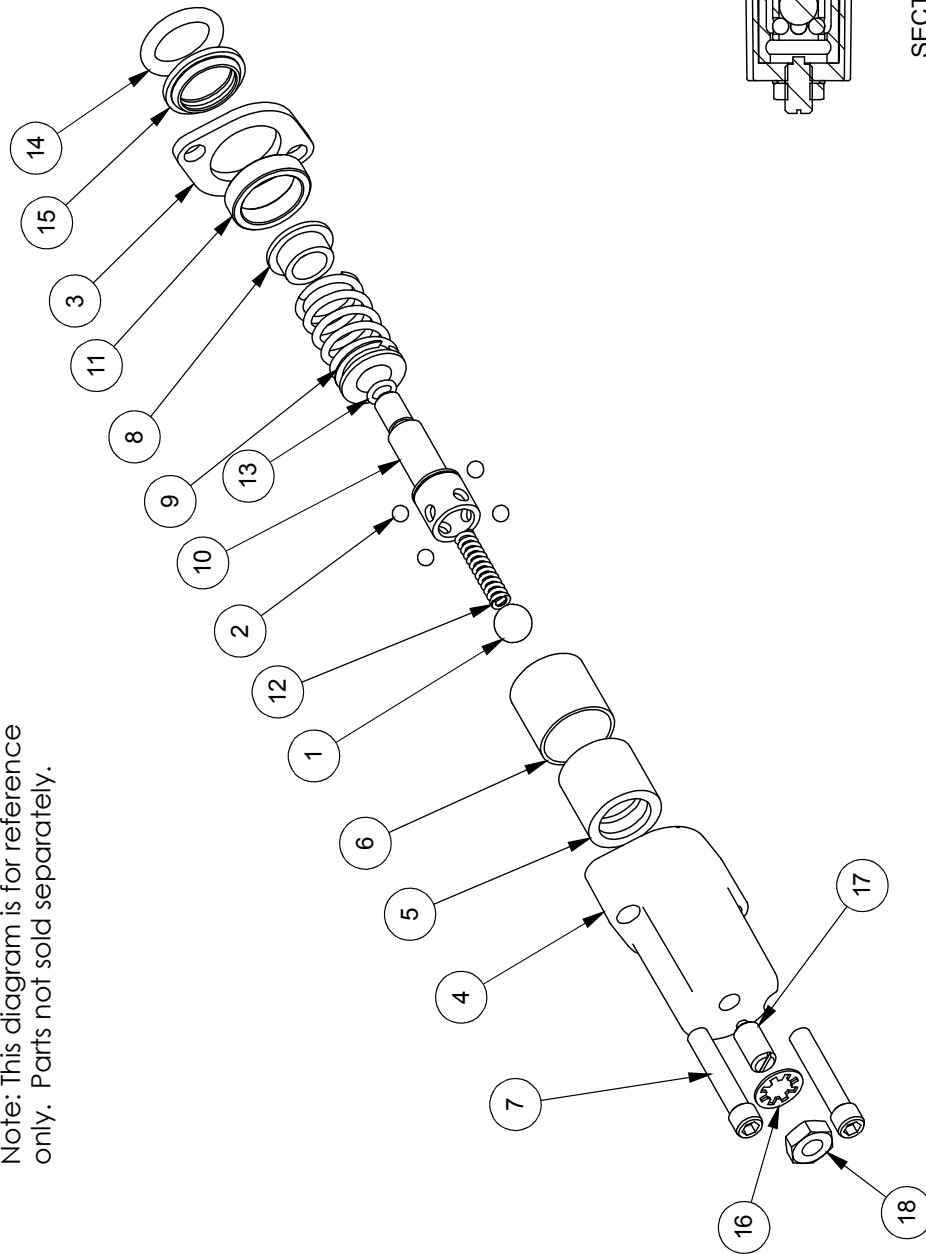

SECTION A-A

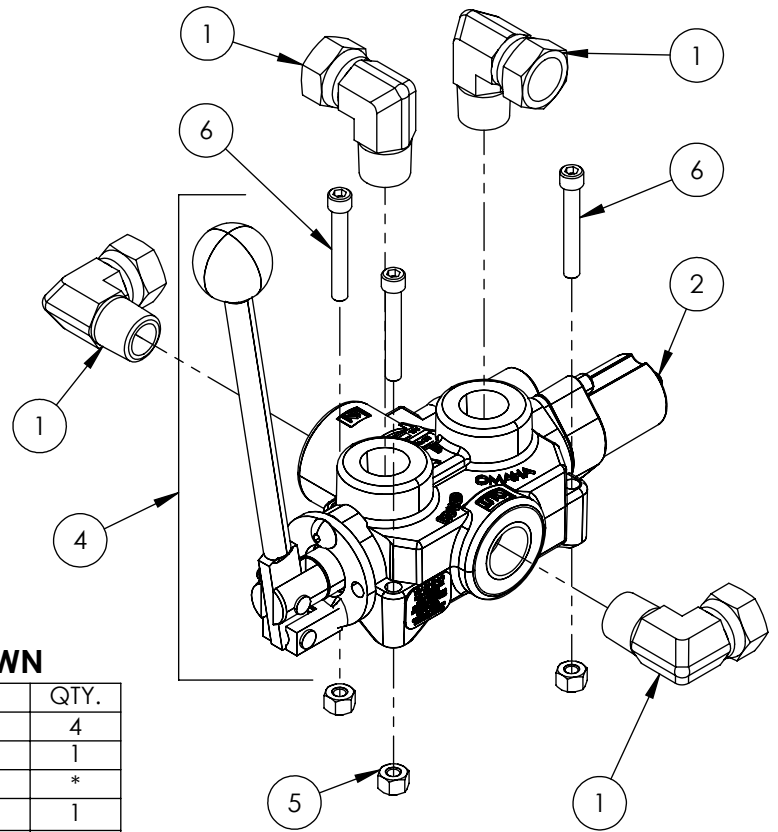

**VALVE AND FITTINGS PARTS BREAKDOWN**

ITEM	PART NO.	Description	QTY.
1	Z51331	Elbow 90 MP x FPX 0808	4
2	Z56209	Valve, Single Function Detent	1
3	*Z56210*	Valve, Closed Center	*
4	Z56915	Complete Handle Kit for Z56209	1
5	Z72111	Hex Lock Nut 1/4NC	3
6	Z75114	SHCS, 1/4NC x 1-3/4	3

\*CLOSED CENTER VALVE REQUIRED FOR "C" MODELS.\*

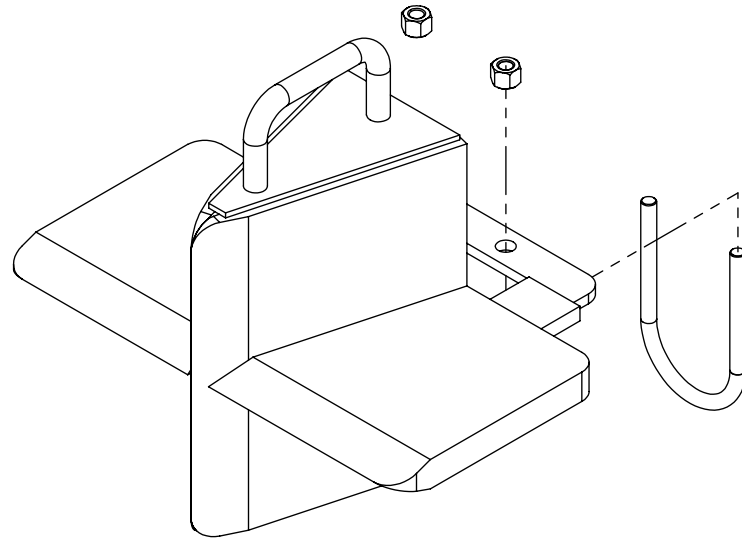

**W4120 4-Way Wedge (Optional)**

ITEM	PART NO.	DESCRIPTION	QTY
1	2082W201	Weldment, Main W4120	1
2	2082S201	Safety U-bolt	1
3	Z72231	Hex Lock Nut 3/8NC	2

### WX350 DECAL BREAKDOWN

ITEM	PART NO.	DESCRIPTION	QTY
1	Z94039	CAUTION - Read Manual	1
2	Z94040	WARNING - Moving Wedge	2
3	Z94067	Clear Guide	2
4	Z94056	Wallenstein	2
5	Z94019	Made in Canada	4
6	Z94066	Apply Oil or Grease	1

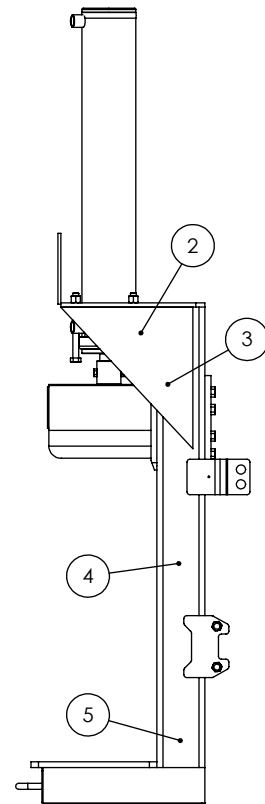
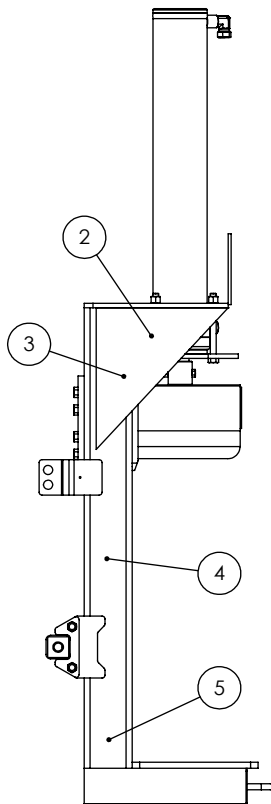
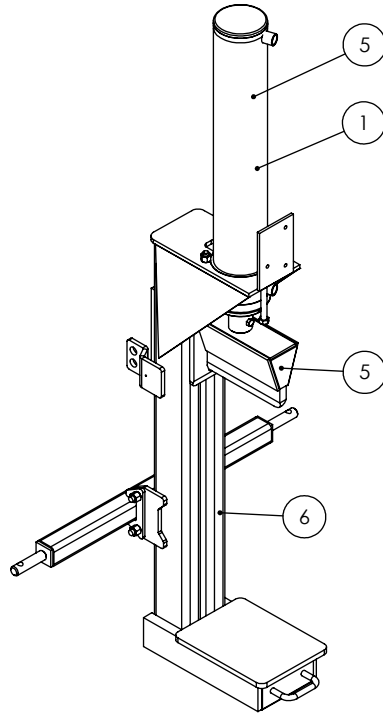

## 3PH Splitter Decals

Z94056



Z94067



Z94019



Z94066

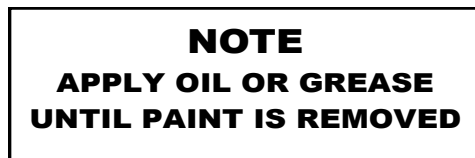

Z94039

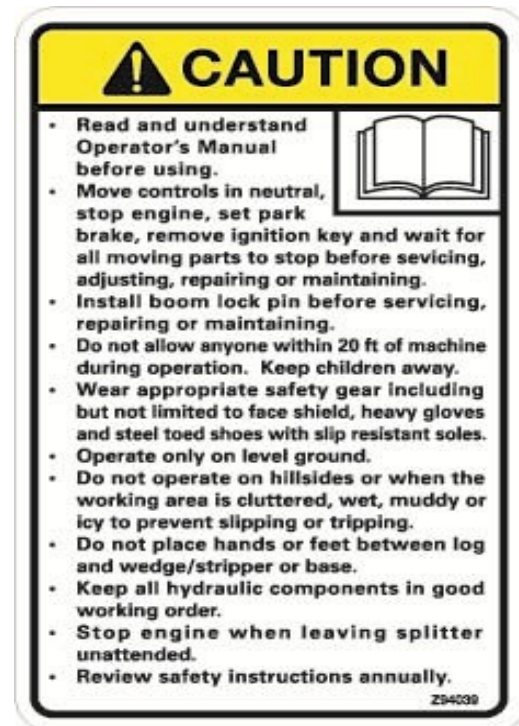

Z94040



### WX350 DECAL BREAKDOWN

ITEM	PART NO.	DESCRIPTION	QTY
1	Z94119	CAUTION - Read Manual	1
2	Z94123	Keep Feet Back	1
3	Z94067	Clear Guide	2
4	Z94056	Wallenstein	2
5	Z94019	Made in Canada	4
6	Z94124	Keep Hands Back	1

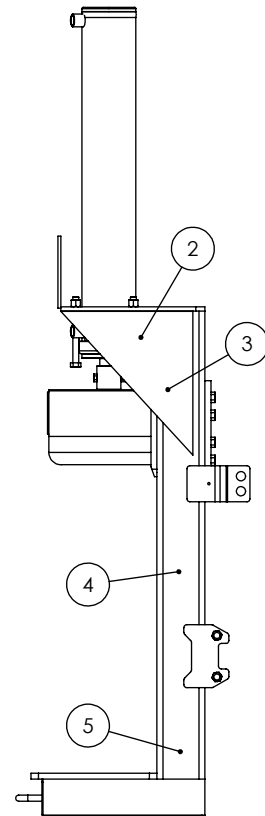
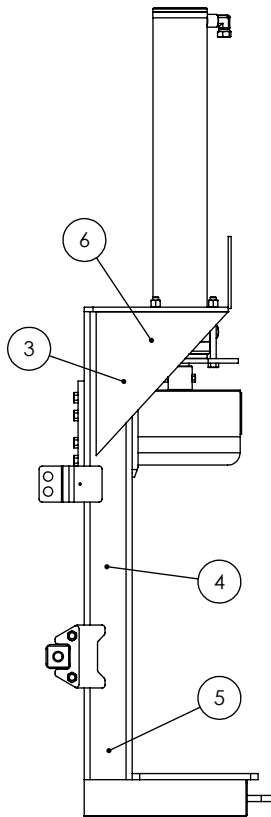
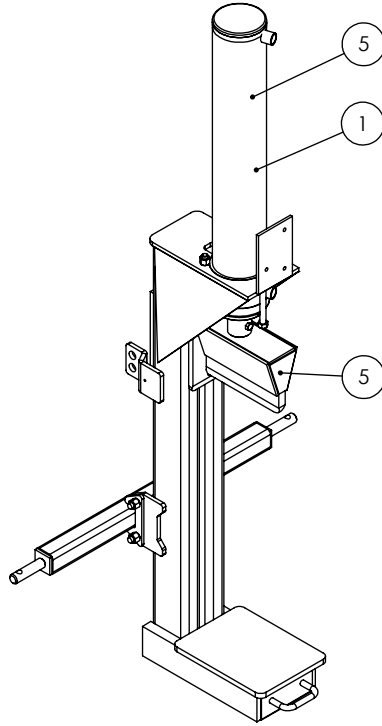

# Two Panel 3PH Splitter Decals

Z94019



Z94067



Z94056



Z94119



Z94123



Z94124





**WALLENSTEIN Products Manufactured by:**

**EMB MFG Inc.**

4144 Boomer Line  
St. Clements, Ontario  
Canada N0B 2M0  
Phone: 1-877-695-9283  
Fax: 519-699-4146  
[www.embmfg.com](http://www.embmfg.com)