

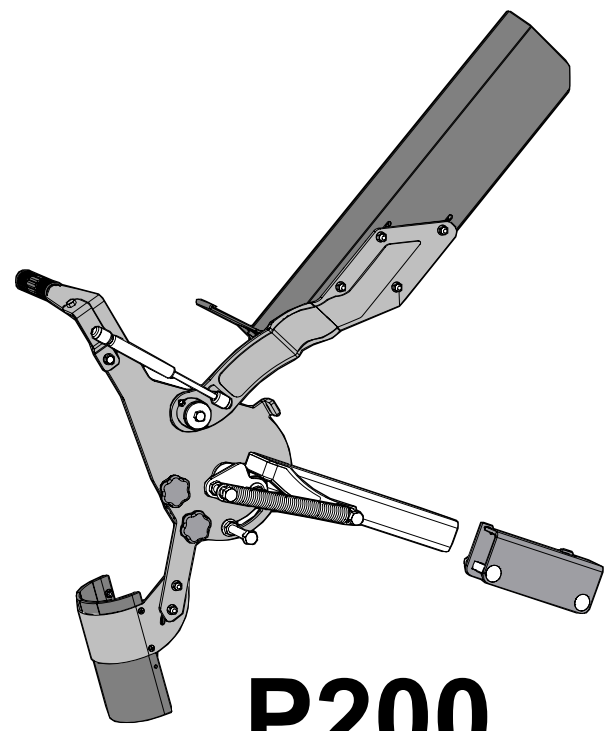

EMB Manufacturing Inc.
4144 Boomer Line · St. Clements, On · N0B 2M0 · Canada
Ph: (519) 699-9283 · Fax: (519) 699-4146
www.embmfg.com



P200

PIVOTING CHAINSAW HOLDER

Accessory Installation Instructions

**Kit #P200: will fit all Wood Processor Models
WP230, WP260, WP630, WP830 & WP860**

Please read these instructions before attempting to assemble, install and operate this kit



This Safety Alert symbol means
ATTENTION! BECOME ALERT! YOUR SAFETY IS INVOLVED!
The Safety Alert symbol identifies important safety messages in this instruction. When you see this symbol, be alert to the possibility of personal injury or death. Follow the instructions in the safety message.

Accessory Installation Instructions

PIVOTING CHAINSAW HOLDER



Always wear the appropriate safety gear when installing this kit or working around the machine. This includes but is not limited to:

- Hard hat for protection to the head.
- Safety glasses protection for the eyes.
- Heavy gloves for hand protection.
- Safety shoes with slip resistant soles and steel toes.



Caution: this kit is constructed of heavy gauge steel, be sure to use caution moving and installing the kit, avoid dropping or pinching body parts on corners and edges of the kit.

The **#P200** kit comes unassembled. Illustrations show typical assembly. This assembly procedure is one time only. Once assembled regular maintenance and only minor adjustments are required.

This kit will work on older version wood processors, and will require a mounting bracket to be welded in place. Newer wood processors will have this bracket pre-installed and will not require any welding.

The maximum diameter of log that your wood processor will handle is 22". We recommend that the chainsaw has an effective cutting area of at least 24" to ensure a full cut on a single pass with a maximum sized log. A smaller chainsaw can be used, but may limit the size of wood that can be cut.

If your wood processor has the bracket shown in the diagram, then proceed to the "Assembly" section of this manual.

If your processor does not have the bracket start at the "Weld" section.

Note: Wood Processors after these serial numbers have chainsaw pivot brackets installed:

WP230	#680005
WP260	#670005
WP630	#640008
WP860	#2E9US1118DS660024

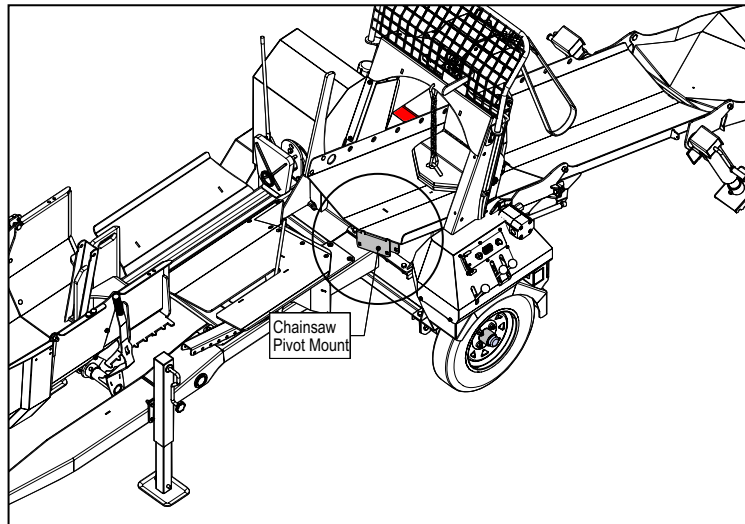

Review your chainsaw manual for safe operating and handling procedures before beginning work.

Installation Instructions:



Ensure the wood processor and the area around it is clean and free of debris, resting on dry level ground, wheel chock applied and the engine shut off. Have the P200 kit close by on a work surface.

Unpack the pivot kit, using the parts list in the back of this manual check that all parts are included. All hardware and small parts are packaged in a plastic hardware bag.

WELD

1. If your wood processor does not have the bracket shown in the diagram then you will have to weld on the mounting bracket included with this kit.
2. The bracket will be mounted to the log chute. On the top of the chute measure 7.5cm (3") from the inside edge and mark the spot. (see illustration)
3. Place the bracket on the edge of the log chute so that the tabs butt up against the edge, set the bracket at the 7.5cm (3") mark and clamp in place.
4. Weld the bracket, let it cool and touch up the welded area to prevent rusting.
5. Loosely install the 2 x carriage bolts and nuts.

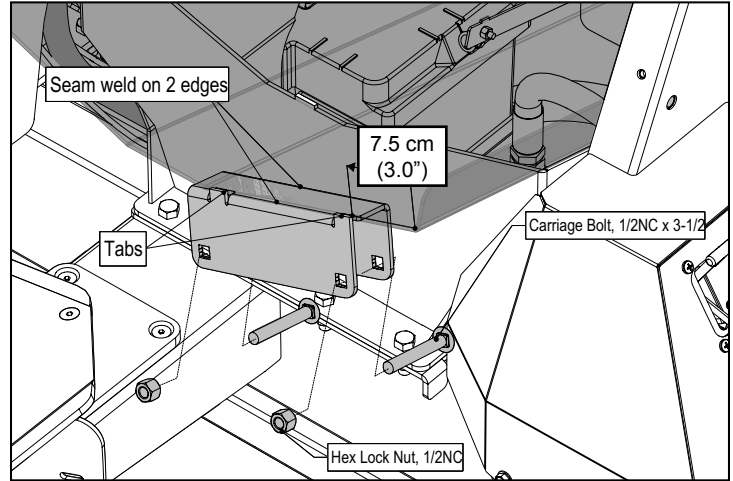

ASSEMBLY

Before you start, you'll need some grease and tools: wrenches and sockets,

- 5/16"
- 7/16"
- 1/2"
- 9/16"
- 3/4"

1. Assemble the 2 parts of the debris guard as shown in the diagram. Set the assembly aside.

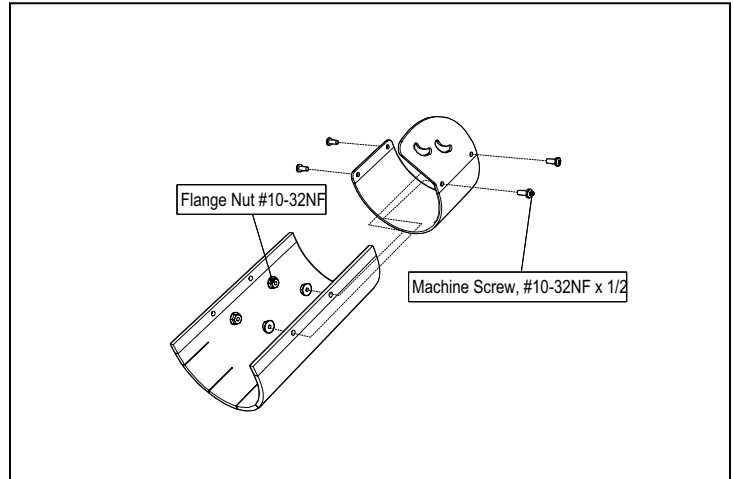

2. Follow the diagram and assemble the 2 parts of the chain guard, and the ball stud. Set the assembly aside.

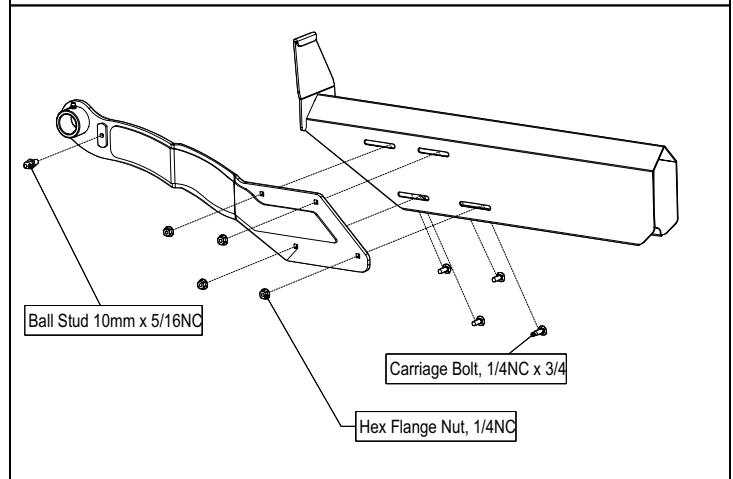

- Find the chainsaw pivot weldment, assemble the spring mount clip and hardware to the weldment as shown in the diagram. Set the assembly aside.

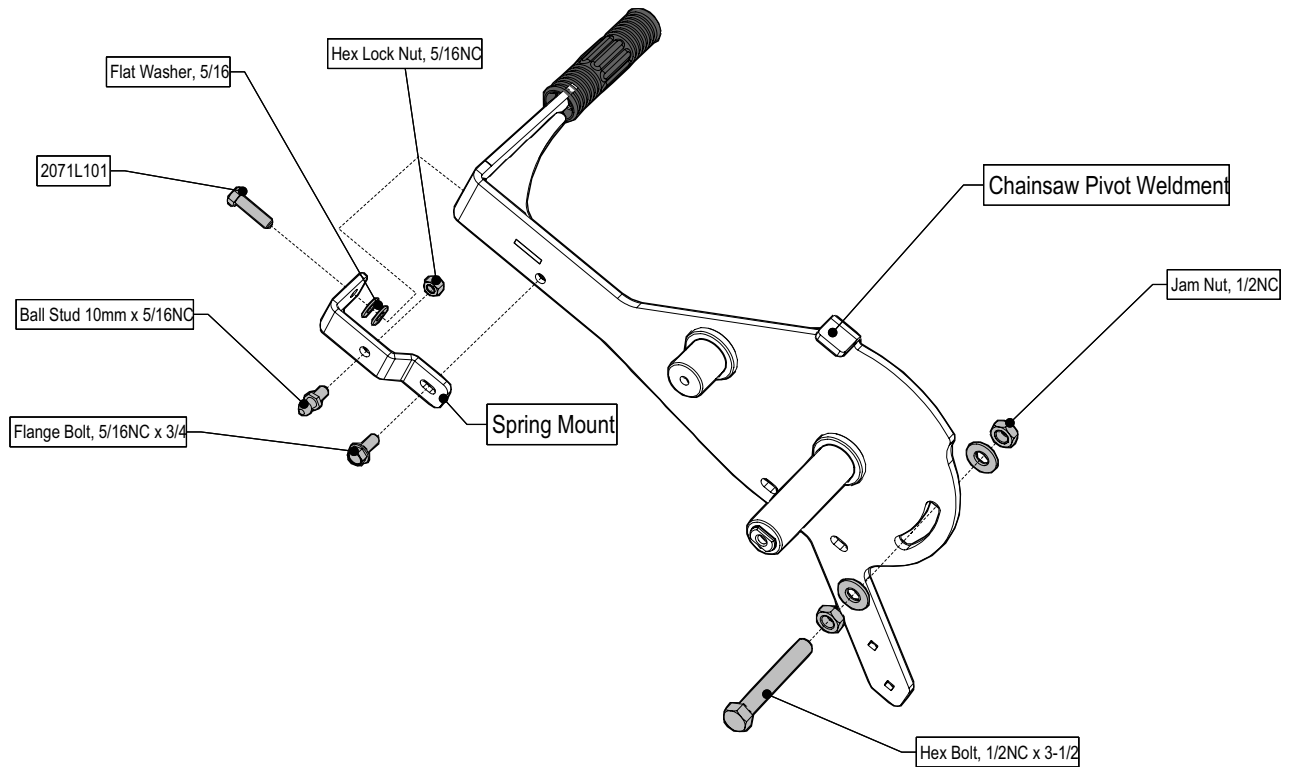

- Begin the main assembly by placing the Pivot base in to pivot clamp on the wood processor, install the 2 x carriage bolts and nuts, and loosely tighten the nuts
- Lightly grease the pivot pin on the weldment assembly, and slide the pivot pin into the pivot base.
- Secure the pivot weldment with the pivot stop washer, hex bolt and washer as shown.
- Find the spring and insert the 2 1/2" hex bolt thru one end of the spring and assemble a hex nut on the end, then assemble to the pivot stop washer with a hex nut.
- Insert the 2" hex bolt thru the other end of the spring, assemble a hex nut on the end, and assemble to the pivot base.
- Tighten up the hex bolts / nuts to secure everything in place.

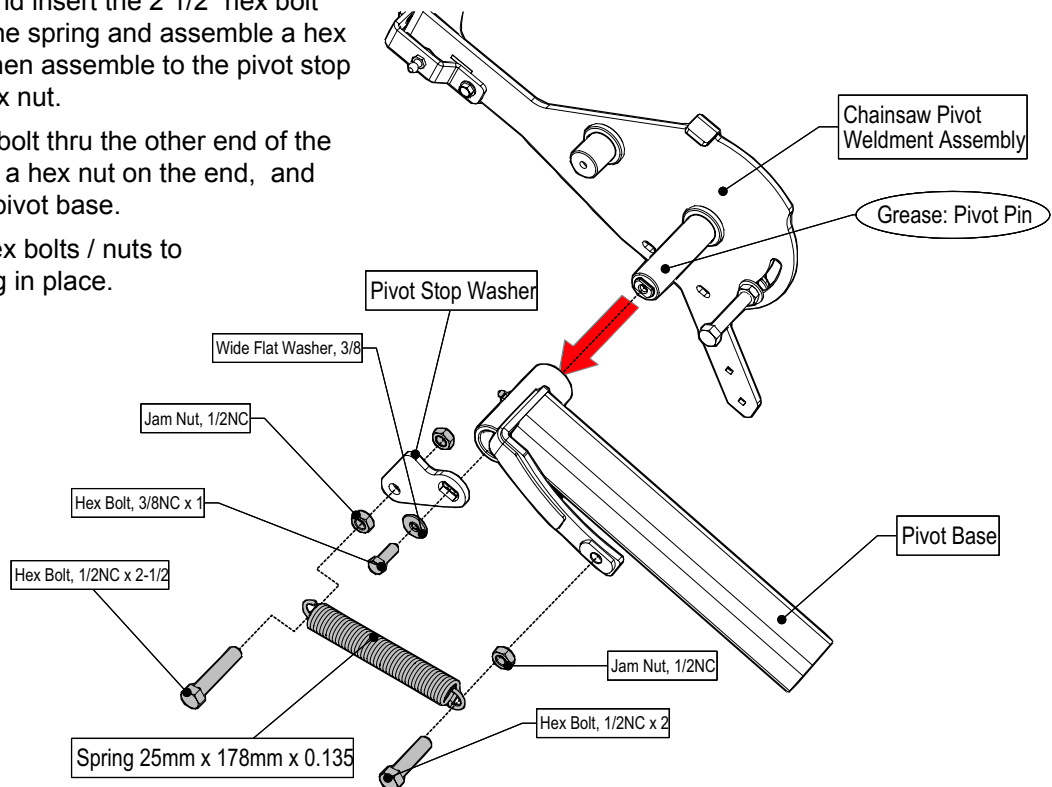

10. Find the debris guard and install onto the main assembly with the 2 x carriage bolts and hex flange nuts.
11. Lightly grease the guard pivot pin, and slide the chainsaw guard onto the pin, securer the guard with the hex bolt and washer.
12. Snap the gas spring into place onto the ball studs of the chainsaw guard and main assembly.

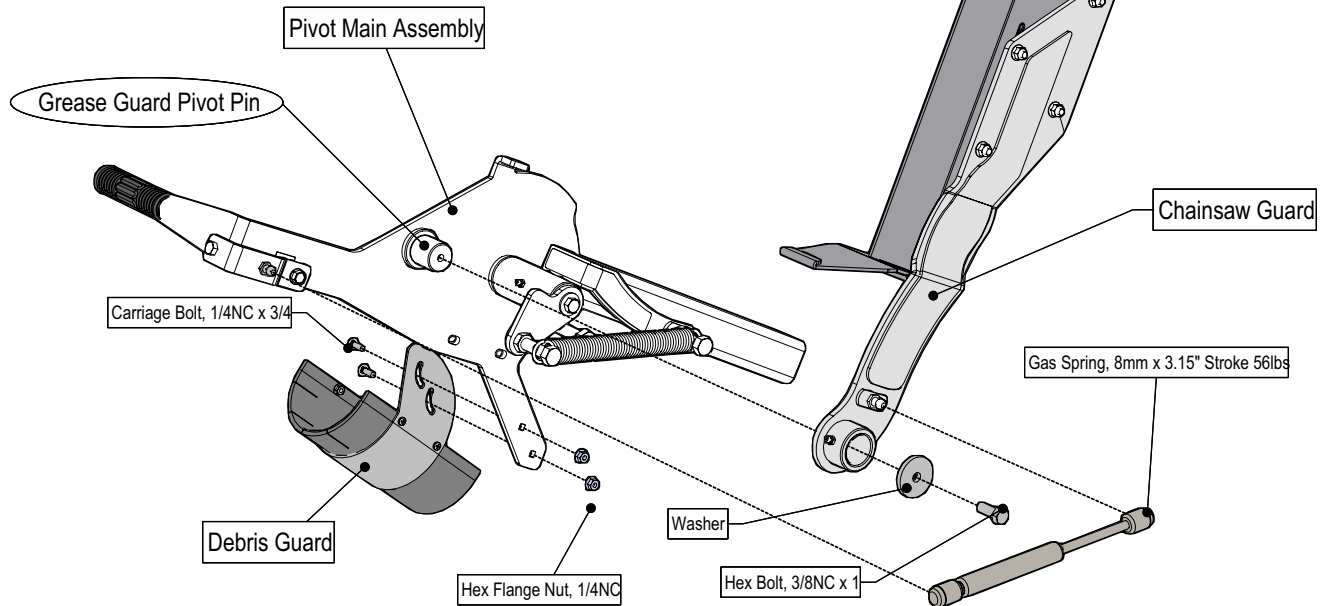

13. Remove the guidebar nuts on the chainsaw.
14. Install the 2 x bar mounting studs onto the chainsaw guidebar studs. Tighten down mounting studs.
15. Assemble the elliptical insert to the mounting studs with the 2 x hex bolts, and tighten down.

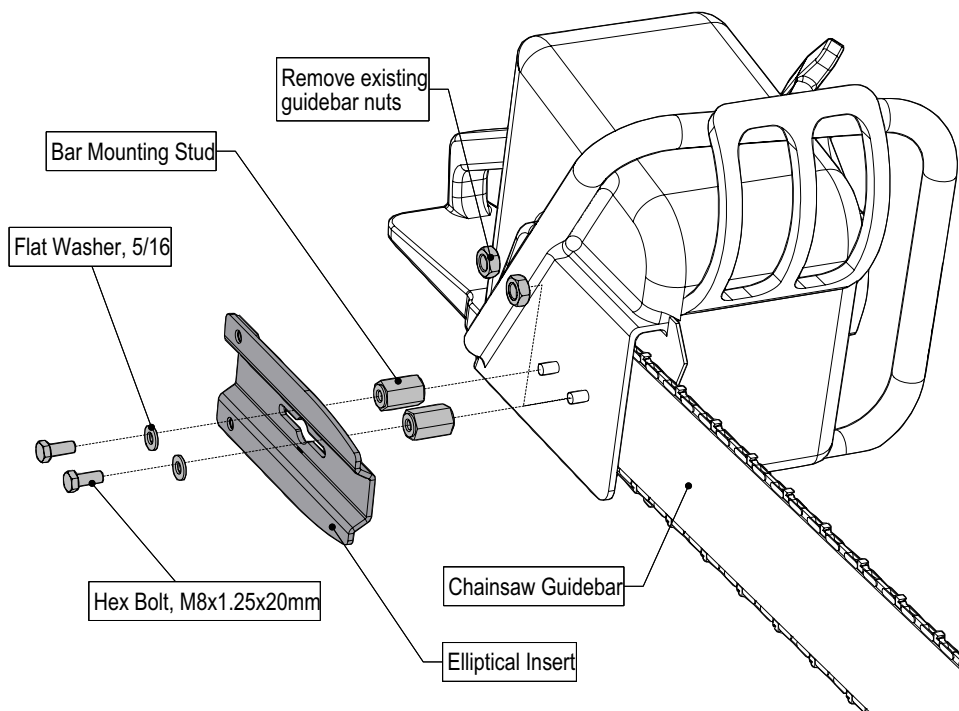

16. Slide the chainsaw into the gibb plates on the main pivot assembly.

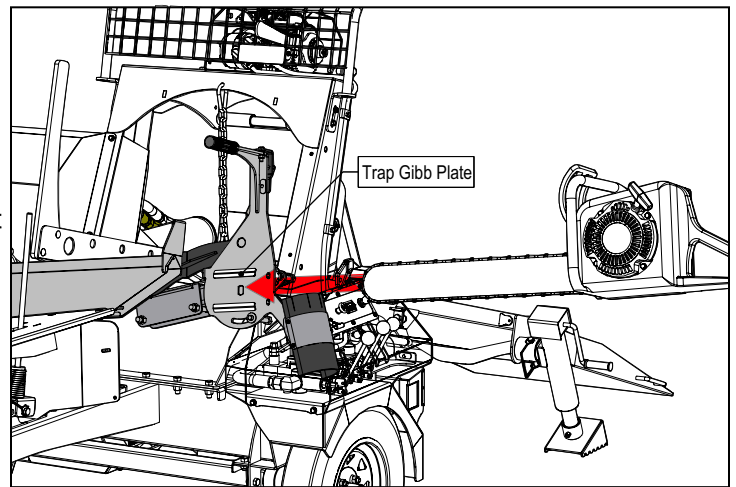

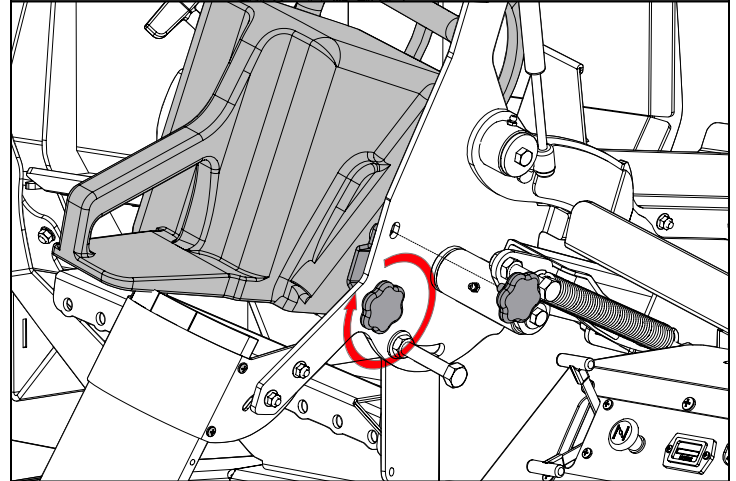

17. Install the 2 x plastic knobs to secure the chainsaw to the pivot main assembly.



18. To make adjustments to the cutting range of the chainsaw, loosen the 2 hex nuts on the pivot clamp and adjust the pivot in or out as required.

19. Anytime an adjustment is made to the pivot, always check for clearance in the chainsaws movement to prevent accidental contact with parts of the processor while the chainsaw is running.

 Always ensure the chainsaw pivot is in the up position before pulling up any logs or operating the splitter ram, damage or injury could result from parts colliding.

 Always apply the chainsaw brake while working around the chainsaw while it is idling.

 After making adjustments to the chainsaw pivot, always check that there is sufficient clearance throughout the chainsaws range of movement to prevent accidental contact between the chainsaw and the processor.

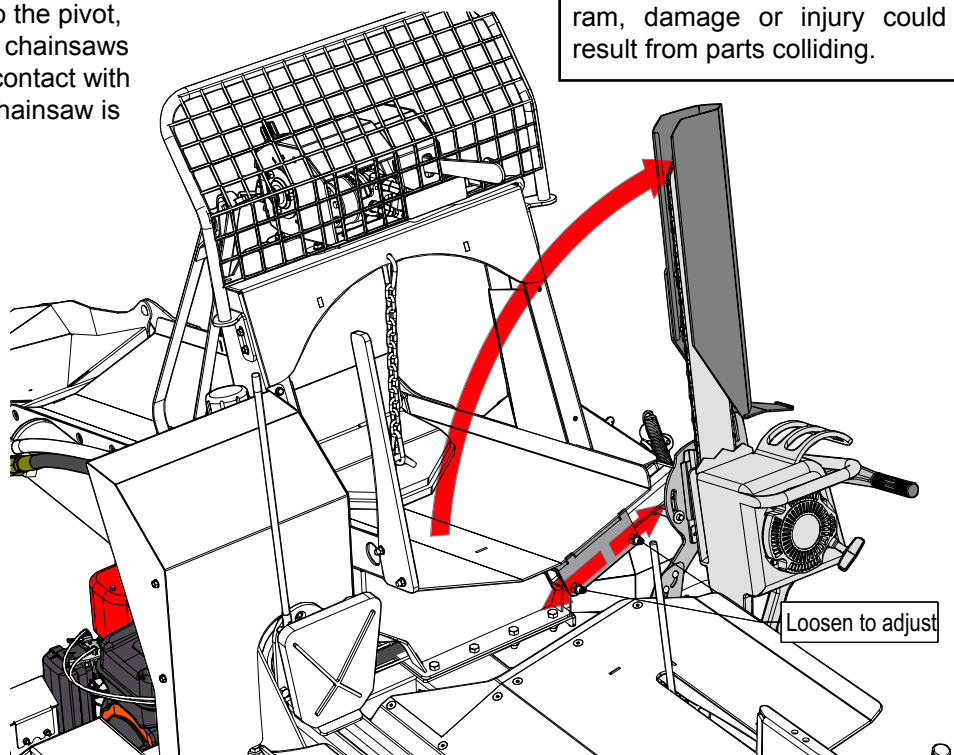

P200 Chainsaw Pivot Parts List

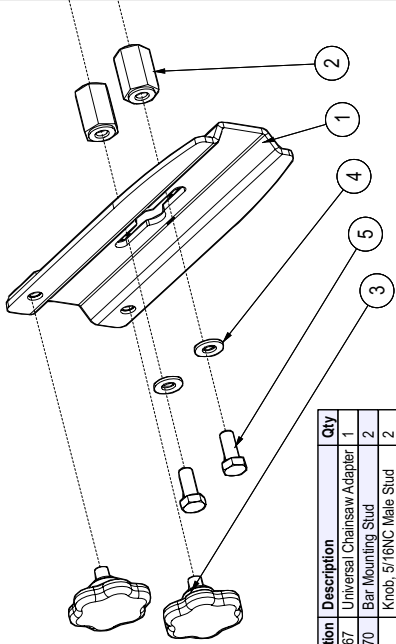

BOM ID	Description	Qty
1	Universal Chainsaw Adapter	1
2	Bar Mounting Stud	2
3	Knob, 5/16NC Male Stud	2
4	Flat Washer, 5/16	2
5	Hex Bolt, M8x1.25x20mm	2

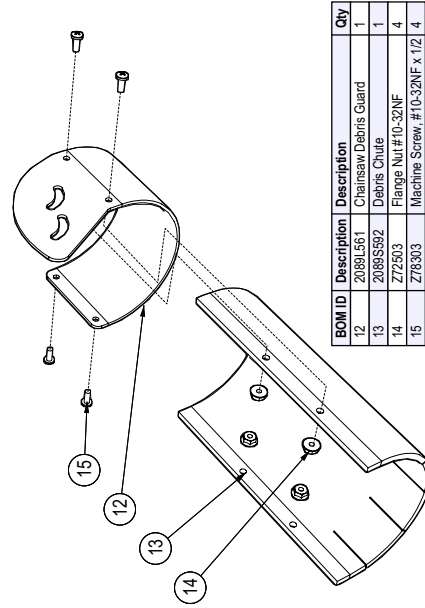

BOM ID	Description	Qty
12	2089L561 Chainsaw Debris Guard	1
13	2089S592 Debris Chute	1
14	Z77503 Flange Nut #10-32NF	4
15	Z75303 Machine Screw #10-32NF x 1/2	4

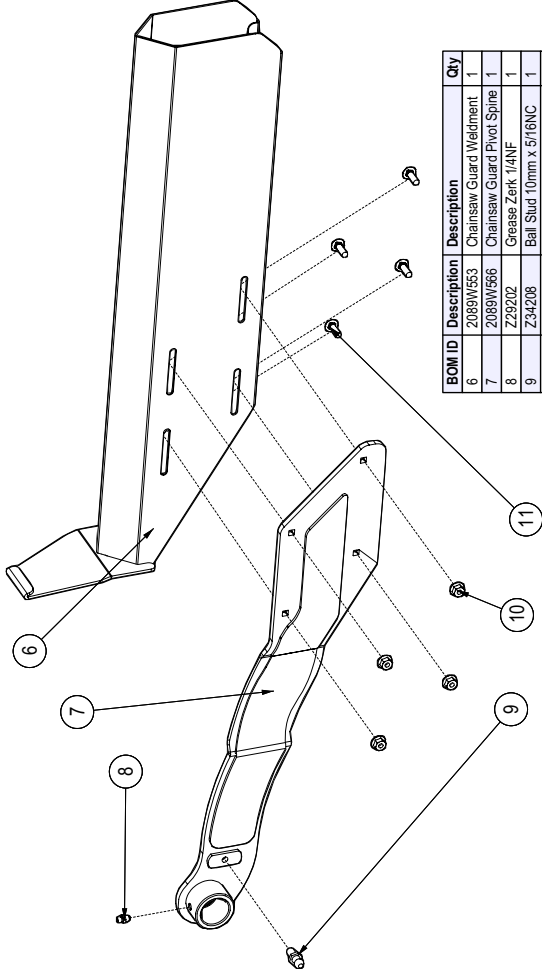

BOM ID	Description	Qty
6	2089W553 Chainsaw Guard Weldment	1
7	2089W566 Chainsaw Guard Pivot Spine	1
8	Z29202 Grease Zerk 1/4NF	1
9	Z34208 Ball Stud 10mm x 5/16NC	1
10	Z72511 Hex Flange Nut, 1/4NC	4
11	Z76211 Carriage Bolt, 1/4NC x 3/4	4

BOM ID	Description	Qty
16	2089W562 Chainsaw Pivot Weldment	1
17	2089W565 Pivot Base	1
18	2089L574 Pivot Stop Washer	1
19	2089L595 Chainsaw Pivot Base Mount	1
20	2089L599 Spring Mount	1
21	Z19321 Grip, 1" x 5"	1
22	Z29202 Grease Zerk 1/4NF	1
23	Z31404 Spring 25mm x 178mm x 0.135	1
24	Z34208 Ball Stud 10mm x 5/16NC	1
25	Z71212 Hex Bolt, 5/16NC x 1-1/4	1
26	Z71310 Hex Bolt, 3/8NC x 1	1
27	Z71620 Hex Bolt, 1/2NC x 2	1
28	Z71625 Hex Bolt, 1/2NC x 2-1/2	1
29	Z71635 Hex Bolt, 1/2NC x 3-1/2	1
30	Z72221 Hex Lock Nut, 5/16NC	2
31	Z72251 Hex Lock Nut, 1/2NC	2
32	Z72351 Jam Nut, 1/2NC	5
33	Z73122 Flat Washer, 5/16	2
34	Z73151 Flat Washer, 1/2	2
35	Z73231 Wide Flat Washer, 3/8	1
36	Z76121 Flange Bolt, 5/16NC x 3/4	1
37	Z76210 Carriage Bolt, 1/2NC x 3-1/2	2

