

INSTALLATION INSTRUCTIONS

PTO62 & PTO72 PTO Pump Kit for Backhoes

Wallenstein PTO Hydraulic Pump Kit is required when mounting a Wallenstein backhoe on a tractor that does not have auxiliary hydraulic power.

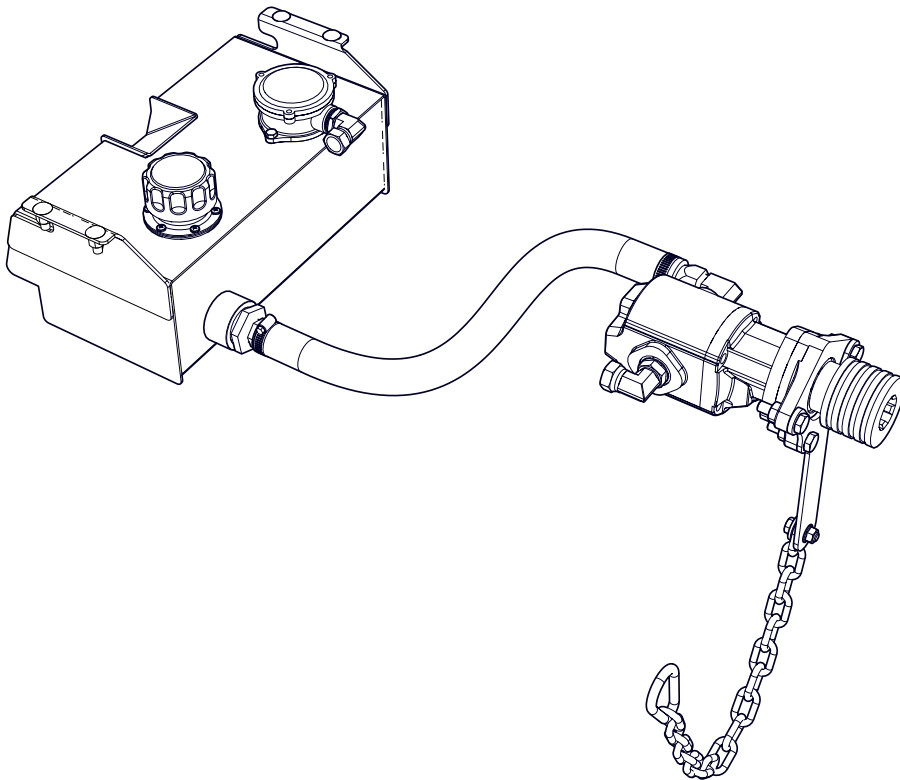

Z97824_En

Safety

Safety Alert Symbol

This Safety Alert Symbol means:

ATTENTION! BE ALERT!

YOUR SAFETY IS INVOLVED!

The **Safety Alert Symbol** identifies important safety messages on the machine and in this instruction. This symbol means be alert to the possibility of personal injury or death. Follow instructions provided.



Signal Words

The signal words **DANGER**, **WARNING** and **CAUTION** determine the seriousness level of the warning messages in this manual. The appropriate signal word for each message in this manual has been selected using the following guidelines:

DANGER –

Indicates an imminently hazardous situation that, if not avoided, **will** result in death or serious injury. This signal word is to be limited to the most extreme situations typically for machine components which, for functional purposes, cannot be guarded.

WARNING –

Indicates a potentially hazardous situation that, if not avoided, **could** result in death or serious injury, and includes hazards that are exposed when guards are removed. It may also be used to alert against unsafe practices.

CAUTION –

Indicates a potentially hazardous situation that, if not avoided, **may** result in minor or moderate injury. It may also be used to alert against unsafe practices.

IMPORTANT – To avoid confusing equipment protection with personal safety messages, a signal word **IMPORTANT** indicates a situation that if not avoided, could result in damage to the machine.

Equipment Operation

 **WARNING!**

Avoid the risk of personal injury or machine damage! Read the operator's manual before using this equipment. Carefully read all safety messages in the manual and follow all safety signs on the machine.

Operator Orientation

The directions left, right, front and rear as mentioned throughout this instruction, are determined when sitting in the tractor driver's seat, facing the direction of forward travel.

Parts Breakdown

PT062

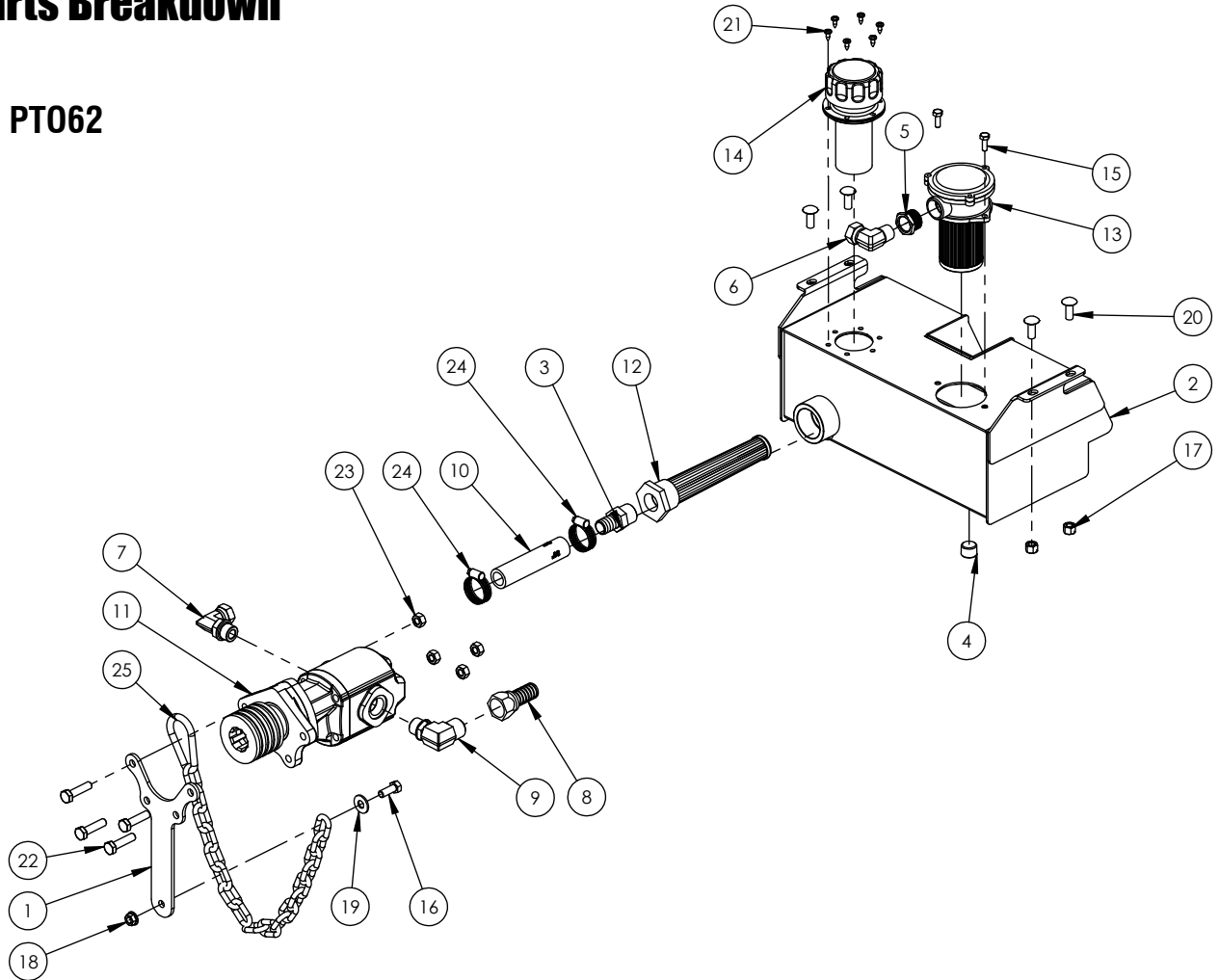

ITEM	PART NO.	DESCRIPTION	QTY
1	3081L107	Lever, Stop	1
2	3081W101	Tank, 2-1/2 Gallon	1
3	Z51181	3/4NPT x 3/4 Hose Barb	1
4	Z51192	Socket Plug 1/2NPT	1
5	Z51221	Reducer FP x MP 1208	1
6	Z51331	Elbow 90 MP x FPX 0808	1
7	Z51384	#10ORB x 1/2FNPT 90 Elbow	1
8	Z51591	#12JIC x 3/4 Hose Barb	1
9	Z51654	#12JIC x #10ORB 90 Elbow	1
10	Z52403	3/4 Plain Hose x 36"	1
11	Z53102	Pump, 2.38 CIR	1
12	Z55101	Tank Strainer, Suction	1
13	Z55201	Tank Mounted Return Filter	1
14	Z55401	Breather Filler Cap	1
15	Z71107	Hex Bolt 1/4NC x 3/4	2
16	Z71310	Hex Bolt 3/8NC x 1	1
17	Z72231	Hex Lock Nut 3/8NC	4
18	Z72531	Flange Nut 3/8NC	1
19	Z73230	Wide Flat Washer 3/8	1
20	Z76231	Carriage Bolt 3/8NC x 1	4
21	Z76711	Self-tapping Screw #10	6
22	Z77161	Hex Bolt, M10 x 40mm	4
23	Z77260	Hex Nut, M10	4
24	Z79401	Hose Clamp, #16	2
25	Z92303	Safety Chain 1/4 x 2'	1

— Seal Kit SK FP20-R-13T1

— Return Filter Element HEK06-10.100-AS-MS090-O-B

Fig. 1 –PT062 Parts Breakdown

PT072

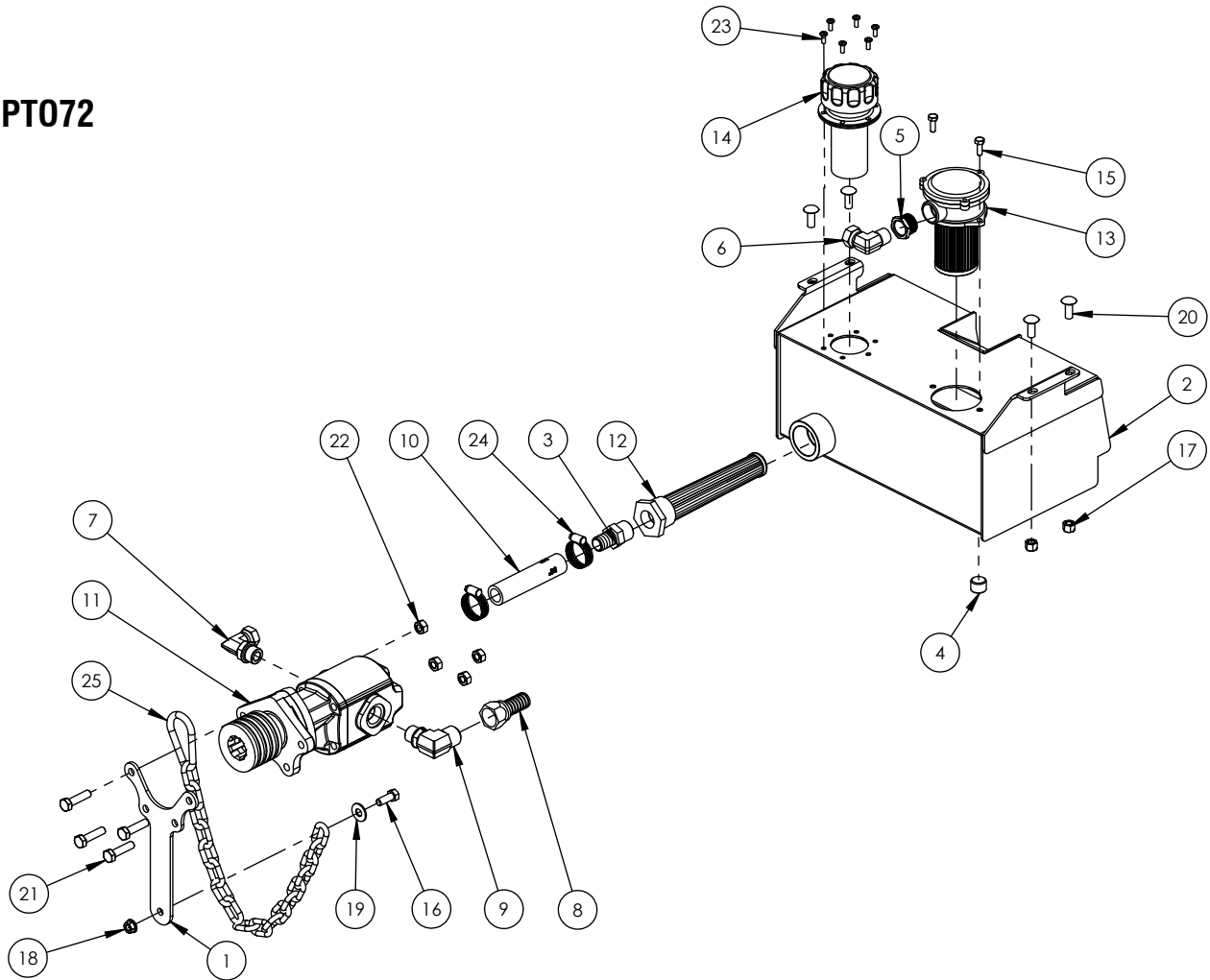

ITEM	PART NO.	DESCRIPTION	QTY
1	3081L107	Lever, Stop	1
2	3081W151	Tank, 3-1/4 Gallon	1
3	Z51181	3/4NPT x 3/4 Hose Barb	1
4	Z51192	Socket Plug 1/2NPT	1
5	Z51221	Reducer FP x MP 1208	1
6	Z51331	Elbow 90 MP x FPX 0808	1
7	Z51384	#10ORB x 1/2FNPT 90 Elbow	1
8	Z51591	#12JIC x 3/4 Hose Barb	1
9	Z51654	#12JIC x #10ORB 90 Elbow	1
10	Z52403	3/4 Plain Hose x 36"	1
11	Z53102	Pump, 2.38 CIR	1
12	Z55101	Tank Strainer, Suction	1
13	Z55201	Tank Mounted Return Filter	1
14	Z55401	Breather Filler Cap	1
15	Z71107	Hex Bolt 1/4NC x 3/4	2
16	Z71310	Hex Bolt 3/8NC x 1	1
17	Z72231	Hex Lock Nut 3/8NC	4
18	Z72531	Flange Nut 3/8NC	1
19	Z73230	Wide Flat Washer 3/8	1
20	Z76231	Carriage Bolt 3/8NC x 1	4
21	Z77161	Hex Bolt, M10 x 40mm	4
22	Z77260	Hex Nut, M10	4
23	Z78303	Machine Screw #10NF x 1/2	6
24	Z79401	Hose Clamp, #16	2
25	Z92303	Safety Chain 1/4 x 2'	1

— Seal Kit SK FP20-R-13T1

— Return Filter Element HEK06-10.100-AS-MS090-O-B

Fig. 2—PT072 Parts Breakdown

Installation Instructions

CAUTION!

Risk of a hazardous situation if kit is installed improperly or modified in any way. Damage to the machine could result. Read and follow all installation and setup instructions.

W091

Tractors without rear hydraulics available for implements require a PTO-driven pump kit. The tractor must have a 1-3/8", 6-spline PTO shaft to fit the pump drive coupler. Shaft adapters cannot be used, and the tractor cannot operate at any speed other than 540 rpm.

IMPORTANT! Installing Wallenstein backhoes on tractors with a variable speed PTO is not recommended. Operating at speeds higher than 540 rpm can overspeed the pump and cause early failures.

PTO Pump Kit ¹	Capacity	Backhoe Model
PT062	7 gpm (26.5 Lpm) oil flow	GX620
	2.5 US gal (9.5 L) reservoir	
PT072	7 gpm (26.5 Lpm) oil flow	GX720, GX920, GX920XT
	3.25 US gal (12.3 L) reservoir	

¹ Make sure pump kit is matched to your backhoe model.

Both PTO Hydraulic Pump Kits install in the same way for all models. Installation and setup instructions apply to both kits unless specified. **Please follow this instruction carefully.**

The PTO Hydraulic Pump Kit comes partially assembled. Illustrations show typical assembly. This assembly procedure is one time only. Once assembled only regular maintenance and minor adjustments are required.

Tighten all hardware using the Bolt Torque table on page 12. Tighten all hydraulic connections using the Hydraulic Fitting Torque table on page 13.

Preparation

- Basic shop tools are required, including 9/16" wrenches and sockets, thread sealant.
- Dexron® III Automatic Transmission Fluid (ATF) is used as hydraulic fluid in this system. Dexron VI or Mercon® ATF are also acceptable substitutions. See capacities noted above.
- Make sure the tractor and the area around it is clean and free of debris. Park on dry, level ground with the brake applied and the engine shut off.
- Leave backhoe on the shipping skid.

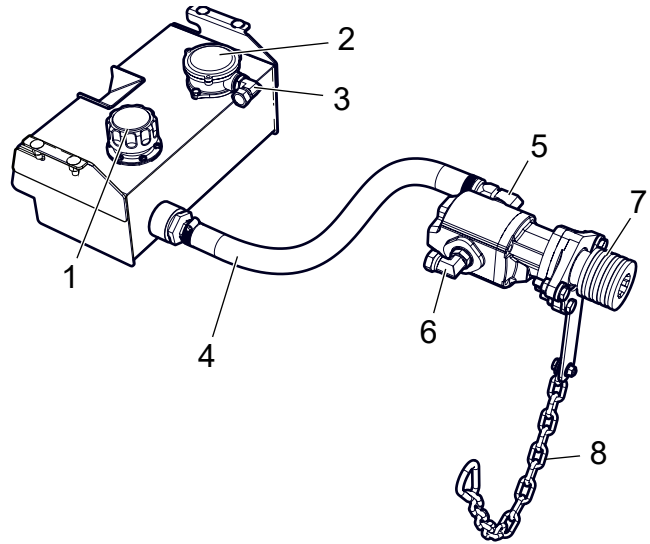

Fig. 3—PTO Pump Kit Parts

1. Reservoir Filler Cap
2. Return Filter
3. Return Connection (from Backhoe)
4. Pump Suction Hose
5. Pump Suction Port
6. Pump Pressure Port (to Backhoe)
7. Locking Collar
8. Safety Chain

Procedure

Before starting, clear the area of any bystanders, especially small children.

Step 1

- On the workbench, attach the 1/2" elbow connector to the filter head (pre-installed on PT072).
- Attach the 3/4" barbed hose fitting to the tank.
- Tighten connections as specified in Hydraulic Fitting Torque on page 13.
- Slip the gear clamps over the suction hose. Attach one end to the tank and to the other end to the input of the PTO pump. Tighten the gear clamps.

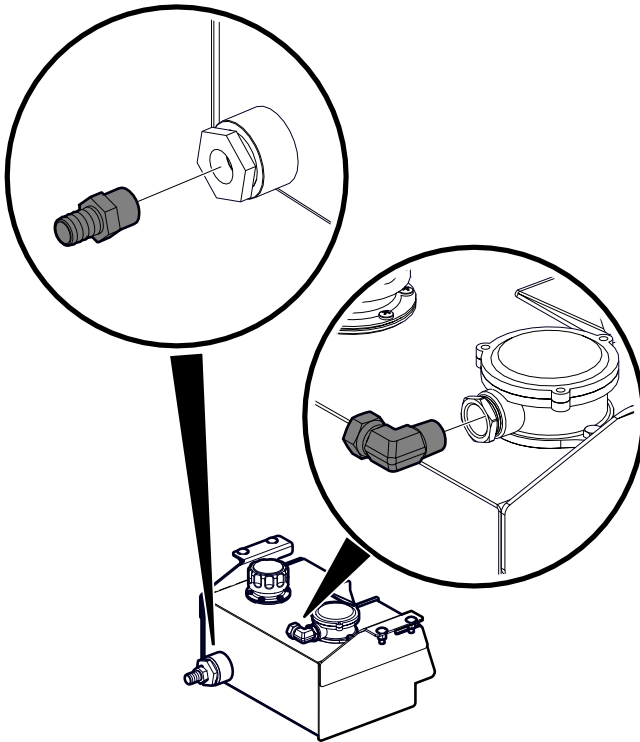

Fig. 4—Reservoir Fittings

Step 2

Prepare to install the reservoir tank by making sure the backhoe frame is clear and the hydraulic hoses are moved out of the way.

- Move the tank into position.
- Install bolts through rectangular holes in the foot rest into the tank mounting holes.
- Adjust the tank position as required then tighten mounting bolts.



Fig. 5—Installing Reservoir in Backhoe Frame

Step 3

Connect the pressure line and return lines. The pressure line is connected to the pump pressure port. The return line is connected to the return connection on the reservoir. (Refer to the illustration on the next page.)

Apply thread sealant to the hose threads to prevent leaks. Tighten connections as specified in the Hydraulic Fitting Torque on page 13.



If unsure, the hoses are connected to the control valve on the backhoe as follows:

- The pressure line on the backhoe is connected to the right-hand side of the control valve at the **P** port (marked on the valve body).
- The return line is connected at the left-hand side of the valve at the **T** port.



Fig. 6—Pressure and Return Hoses

The backhoe directional control valve does not allow reverse flow if lines are connected incorrectly.

Fig. 14—Pressure and Return Line Connections

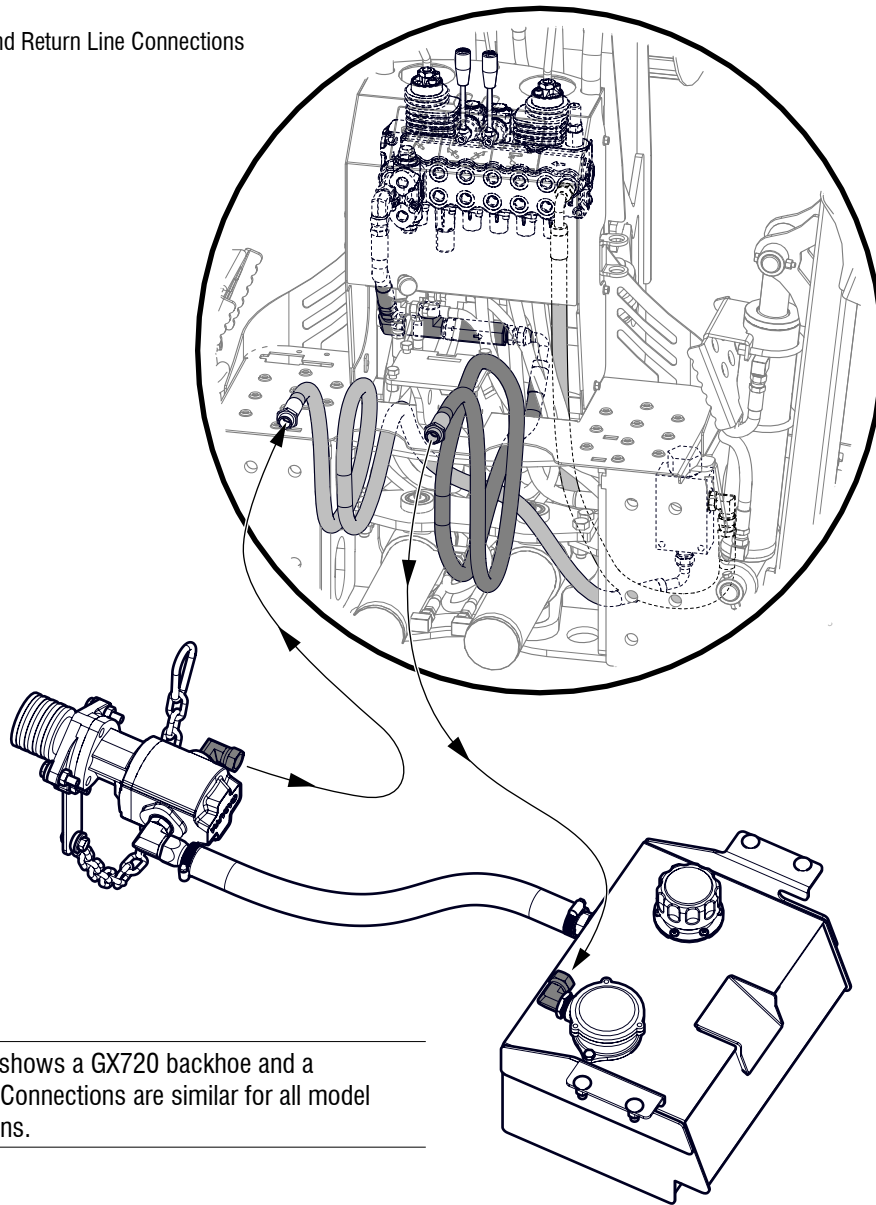

Illustration shows a GX720 backhoe and a PT072 kit. Connections are similar for all model combinations.

! WARNING!

Hydraulic oil under pressure can penetrate the skin or eyes causing serious injury.

- Tighten all connections before applying pressure.
- Search for leaks with a piece of cardboard or wood, not your hand. Take care to protect hands and body from high-pressure fluids. Wear a face shield or goggles for eye protection.
- If an accident occurs, see a doctor familiar with this type of injury immediately.

W040

Step 4

Fill the hydraulic tank and circuit with Dexron® III Automatic Transmission Fluid (ATF). Dexron VI or Mercon® ATF are also acceptable substitutions.

Wipe up any spilled oil.

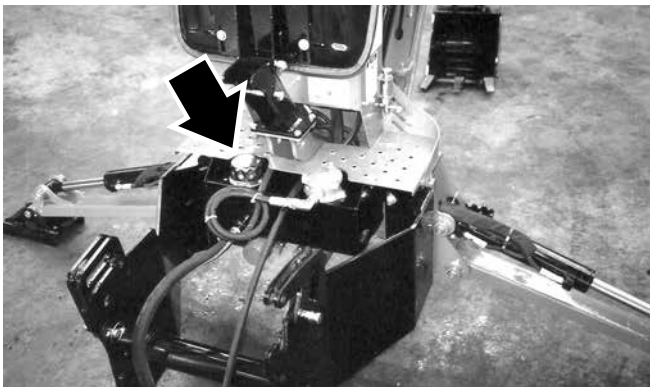

Fig. 7 – Reservoir Filler Cap



Fig. 8 – Fill Reservoir with Oil

Step 5

Reverse the tractor up to the backhoe to connect the pump to the PTO.

! WARNING!

Never let anyone stand between the tractor and the implement during hitching. Too fast of an approach or the operator's foot slipping from the clutch can lead to injury or fatality to the person standing nearby.

W048

Stop close enough so hydraulic hose slack allows the pump to be mounted onto the tractor PTO shaft. Set the park brake and remove the ignition key.



Fig. 9 – Positioning Tractor

Retract the lock collar and slide the pump over the PTO shaft. Make sure the collar seats in the groove and locks. Tug on the pump to ensure the collar has locked.

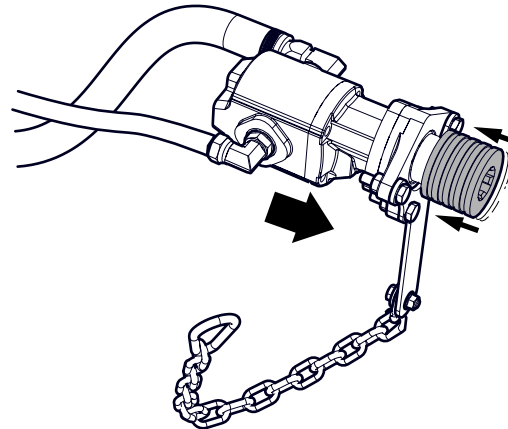

Fig. 10 – Pump Collar and Anchor Chain

Attach the anchor chain to a part of the frame to prevent the pump from turning.

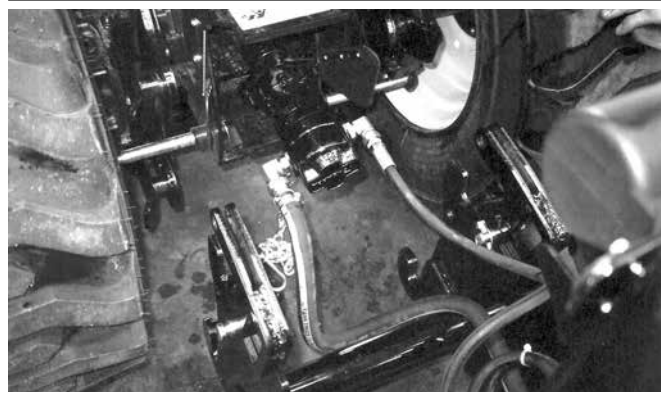

Fig. 11 – Pump Installed



Wrap up any extra hose length into loops and secure with plastic tie wraps.

! WARNING!

Hydraulic oil under pressure can penetrate the skin or eyes causing serious injury.

- Tighten all connections before applying pressure.
- Search for leaks with a piece of cardboard or wood, not your hand. Take care to protect hands and body from high-pressure fluids. Wear a face shield or goggles for eye protection.
- If an accident occurs, see a doctor familiar with this type of injury immediately.

W040

Step 6

Install the backhoe on the tractor following the instructions provided in the Backhoe Operator's Manual.

Test the installation. Start the tractor, set park brake, and engage the PTO. Set the throttle at mid-range to power up the hydraulic system on the backhoe. Carefully move one of the valve control levers to check system function.

! WARNING!

Risk of personal injury from component failure.



Excessive PTO speeds above 540 rpm or incorrect rotation can result in machine damage.

W084

Maintenance**Hydraulic Oil, Changing**

Change the hydraulic oil at 100 hours of operation or annually. Clean the return filter and suction strainer in the hydraulic tank at the same time.

1. Apply parking brake and shut down engine. Allow system to cool.

! CAUTION!

Risk of burns to exposed skin. Hydraulic oil becomes hot during operation. Hoses, lines, and other parts become hot as well. Wait for the oil and components to cool before starting any maintenance or inspection work.

W028

2. Place a drain pan of suitable capacity underneath the reservoir drain plug.

Reservoir capacities:

PT062 2.5 US gal (9.4 L)

PT072 3.25 US gal (12.3 L)

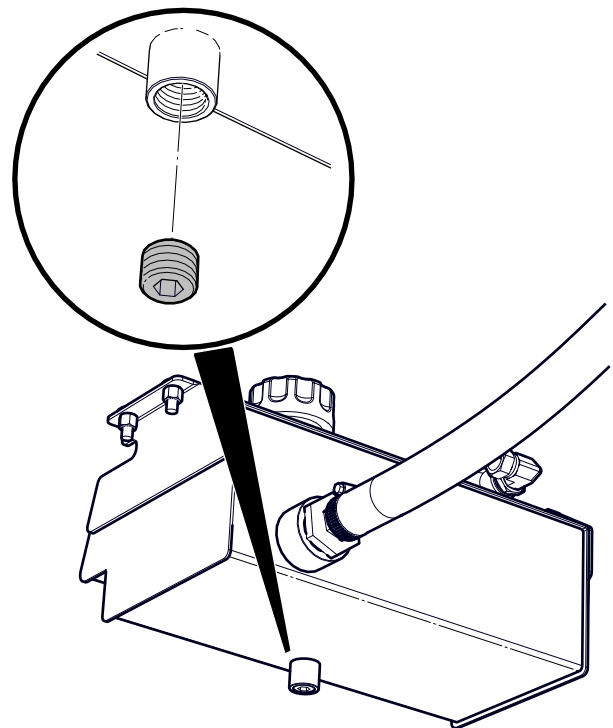

Fig. 12—Reservoir Drain

3. Clean the area around drain and remove the drain plug.
4. Allow the oil to fully drain, then flush the tank. Dispose of used oil in an environmentally acceptable fashion.
5. Install the drain plug.
6. Clean the filter suction strainer before filling the tank.

IMPORTANT! Dispose of the waste fluid in an environmentally responsible way at a chemical recycler or in accordance with hazardous waste laws in your area. Do not dispose of the fluid in any way that would result in contaminating the environment.

IMPORTANT! Clean return filter element and suction strainer when reservoir oil is changed.

Suction Strainer – Cleaning

With the hydraulic tank emptied, the suction strainer should be removed and cleaned. The strainer is made of stainless-steel screen and is reused.

- Remove the suction hose, then remove the strainer.
- Place the suction strainer in a solvent tank and use a small brush to clean it. Examine the strainer screen and replace it if there are holes or damage.
- Dry the suction screen thoroughly, then re-install.

Hydraulic Oil Filter – Cleaning

With the hydraulic tank emptied, the hydraulic return filter should be removed and cleaned. The filter is made of stainless-steel screen and is reused.

The filter is located on top of the hydraulic oil tank.

- Remove the three screws on the filter cover and pull the cover off.
- Remove the filter element and clean the bottom of the bowl.
- Check that the O-rings are not damaged. If they are, replace them.
- Place the filter element in a solvent tank and use a small brush to clean it. Examine the screen and replace it if there are holes or damage.
- Install the filter. Reinstall the filter cover and tighten the screws to **44 lbf•in (5 N•m)**.

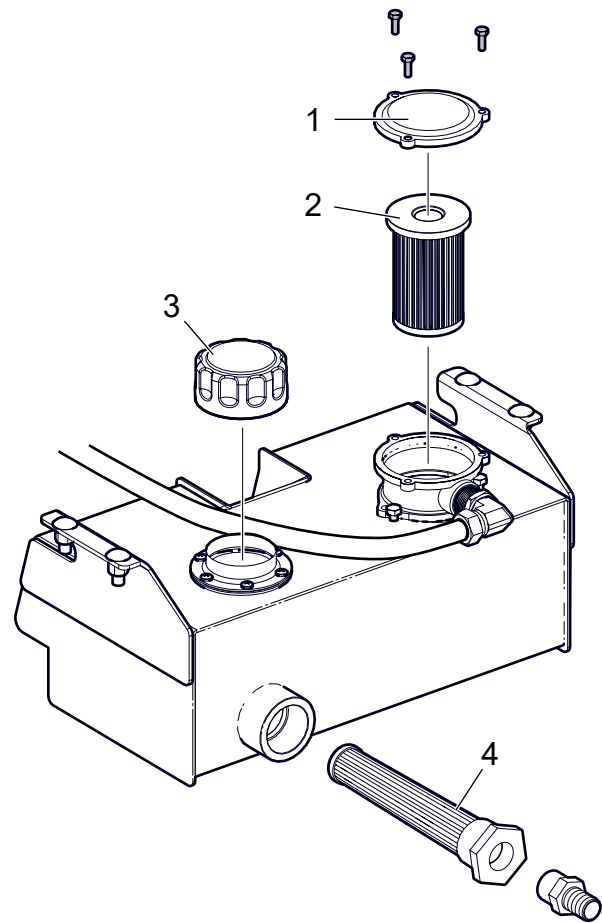

Fig. 13—Return Filter and Suction Strainer

1. Return Filter Cover
2. Return Filter Element
3. Reservoir Filler Cap
4. Suction Strainer

- Fill the reservoir with Dexron® III Automatic Transmission Fluid (ATF). Dexron VI or Mercon® ATF are also acceptable substitutions. Fluid level should be about 1" (25 mm) from the top of the tank. Wipe up any spilled oil.
- Start up the machine and operate the controls for 1–2 minutes. Check for leaks.

Product Warranty



LIMITED WARRANTY

Wallenstein products are warranted to be free of defects in materials and workmanship under normal use and service, for a period of

Five Years for Consumer Use

Two Years for Commercial/Rental Use

from the date of purchase, when operated and maintained in accordance with the operating and maintenance instructions supplied with the unit. Warranty is limited to the repair of the product and/or replacement of parts.

This warranty is extended only to the original purchaser and is not transferable.

Repairs must be done by an authorized dealer. Products will be returned to the dealer at the customer's expense. Include the original purchase receipt with any claim.

This warranty does not cover the following:

- 1) Normal maintenance or adjustments
- 2) Normal replacement of wearable and service parts
- 3) Consequential damage, indirect damage, or loss of profits
- 4) Damages resulting from:
 - Misuse, negligence, accident, theft or fire
 - Use of improper or insufficient fuel, fluids or lubricants
 - Use of parts or aftermarket accessories other than genuine Wallenstein parts
 - Modifications, alteration, tampering or improper repair performed by parties other than an authorized dealer
 - Any device or accessories installed by parties other than an authorized dealer
- 5) Engines. Engines are covered by the manufacturer of the engine for the warranty period they specify. For the details of your engine warranty, see your engine owner's manual. Information about engine warranty and service is also available in the FAQ section at www.wallensteinequipment.com

Bolt Torque Specifications

Checking Bolt Torque

The tables shown give correct torque values for various bolts and capscrews. Tighten all bolts to the torque values specified in the table, unless indicated otherwise. Check tightness of bolts periodically.

IMPORTANT! If replacing hardware, use fasteners of the same grade.

IMPORTANT! Torque figures indicated in the table are for non-greased or non-oiled threads. Do not grease or oil threads unless indicated otherwise. When using a thread locker, increase torque values by 5%.

 **NOTE:** Bolt grades are identified by their head markings.

Imperial Bolt Torque Specifications						
Bolt Diameter	Torque Value					
	SAE Gr. 2		SAE Gr. 5		SAE Gr. 8	
	lbf•ft	N•m	lbf•ft	N•m	lbf•ft	N•m
1/4"	6	8	9	12	12	17
5/16"	10	13	19	25	27	36
3/8"	20	27	33	45	45	63
7/16"	30	41	53	72	75	100
1/2"	45	61	80	110	115	155
9/16"	60	95	115	155	165	220
5/8"	95	128	160	215	220	305
3/4"	165	225	290	390	400	540
7/8"	170	230	420	570	650	880
1"	225	345	630	850	970	1320



Metric Bolt Torque Specifications				
Bolt Diameter	Torque Value			
	Gr. 8.8		Gr. 10.9	
	lbf•ft	N•m	lbf•ft	N•m
M3	0.4	0.5	1.3	1.8
M4	2.2	3	3.3	4.5
M6	7	10	11	15
M8	18	25	26	35
M10	37	50	52	70
M12	66	90	92	125
M14	83	112	116	158
M16	166	225	229	310
M20	321	435	450	610
M30	1,103	1 495	1,550	2 100

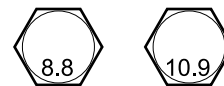

Hydraulic Fitting Torque

Tightening Flare Type Tube Fittings

1. Check flare and flare seat for defects that might cause leakage.
2. Align tube with fitting before tightening.
3. Hand-tighten swivel nut until snug.
4. To prevent twisting the tube, use two wrenches. Place one wrench on the connector body and tighten the swivel nut with the second. Torque to values shown.

If a torque wrench is not available, use the FFFT (Flats From Finger Tight) method.

Hydraulic Fitting Torque					
Tube Size OD	Hex Size Across Flats	Torque value		Flats From Finger Tight	
		Inches	N•m	Flats	Turns
3/16	7/16	6	8	2	1/6
1/4	9/16	11–12	15–17	2	1/6
5/16	5/8	14–16	19–22	2	1/6
3/8	11/16	20–22	27–30	1-1/4	1/6
1/2	7/8	44–48	59–65	1	1/6
5/8	1	50–58	68–79	1	1/6
3/4	1-1/4	79–88	107–119	1	1/8
1	1-5/8	117–125	158–170	1	1/8

Values shown are for non-lubricated connections.



WallensteinEquipment.com