

PARTS MANUAL

Serial number 1102385 and up

WXT15H Log Splitter

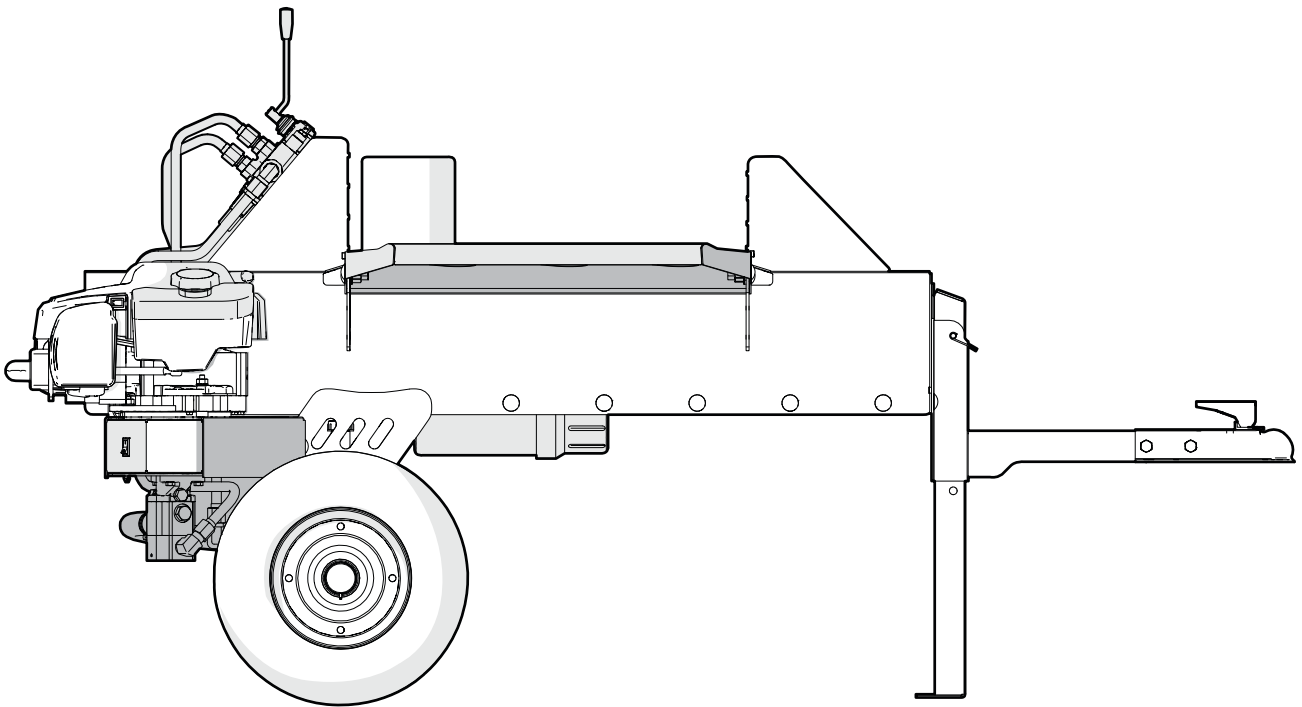

Revision B Oct-2024

Part Number: 2074TA000

WALLENSTEIN

Table of Contents

Introduction	3
Model and Serial Number Location.....	3
Main Parts.....	4
Log Base Assembly	5
Main Base Assembly.....	6
Engine and Hydraulics Assembly	7
Valve Assembly	8
Hydraulic Circuit.....	9
Label Locations	10
Accessories	11
Bolt Torque	12
Hydraulic Fitting Torque.....	13

Introduction

! WARNING!

For safety, operation, and maintenance information, see the Operator’s Manual for your product.

Only qualified people are approved to maintain the machine.

! WARNING!

Replace all safety labels that are missing, damaged, or illegible. If a component is replaced and it has a safety label on it, apply a safety label to the new component. If a person operates a machine with missing, damaged, or illegible safety labels it puts them at risk of serious injury or death.

W100

This document provides information about the original equipment manufacturer (OEM) components (parts). Always replace a part with the correct OEM part. For service, support, or to order parts, contact your local Wallenstein Equipment dealer or distributor.

Always provide the model and serial number of your Wallenstein product when you order parts, or request service or other information. The model and serial number location is shown in the following illustration.

Record the model and serial number of your product here:

Model	
Serial Number	

The information contained in this document was current at the revision date noted on the bottom of each page. Wallenstein Equipment reserves the right to change product specifications at any time without notice. If your product specifications are different from the information in this document, contact your local dealer or distributor. To find a local dealer or distributor, go to WallensteinEquipment.com and select **Dealer Locator** at the bottom of the page.

Wallenstein Equipment Inc. • © 2024. All rights reserved.

No part of this work may be copied, reproduced, replaced, distributed, published, displayed, modified, or transferred in any form or by any means except with the prior permission of Wallenstein Equipment Inc.

Model and Serial Number Location

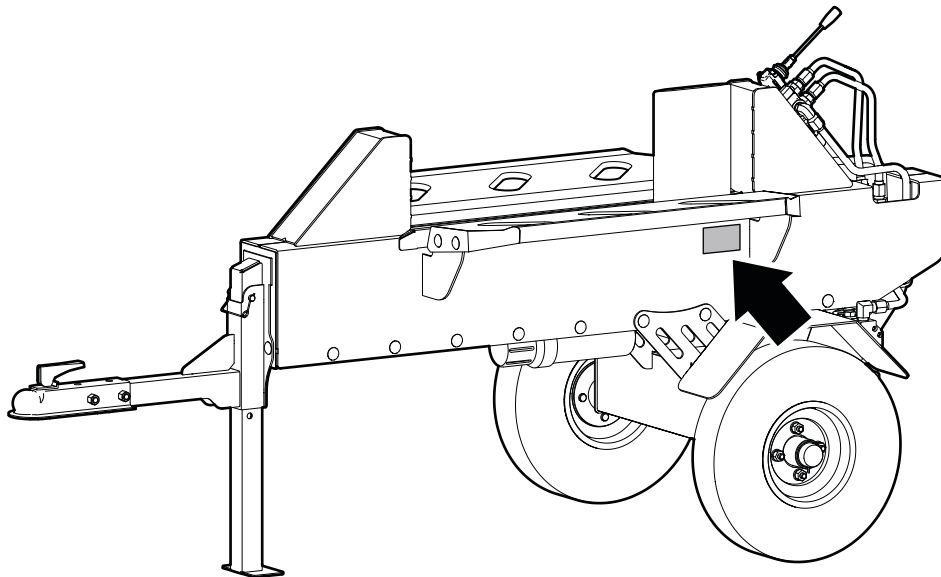

Main Parts

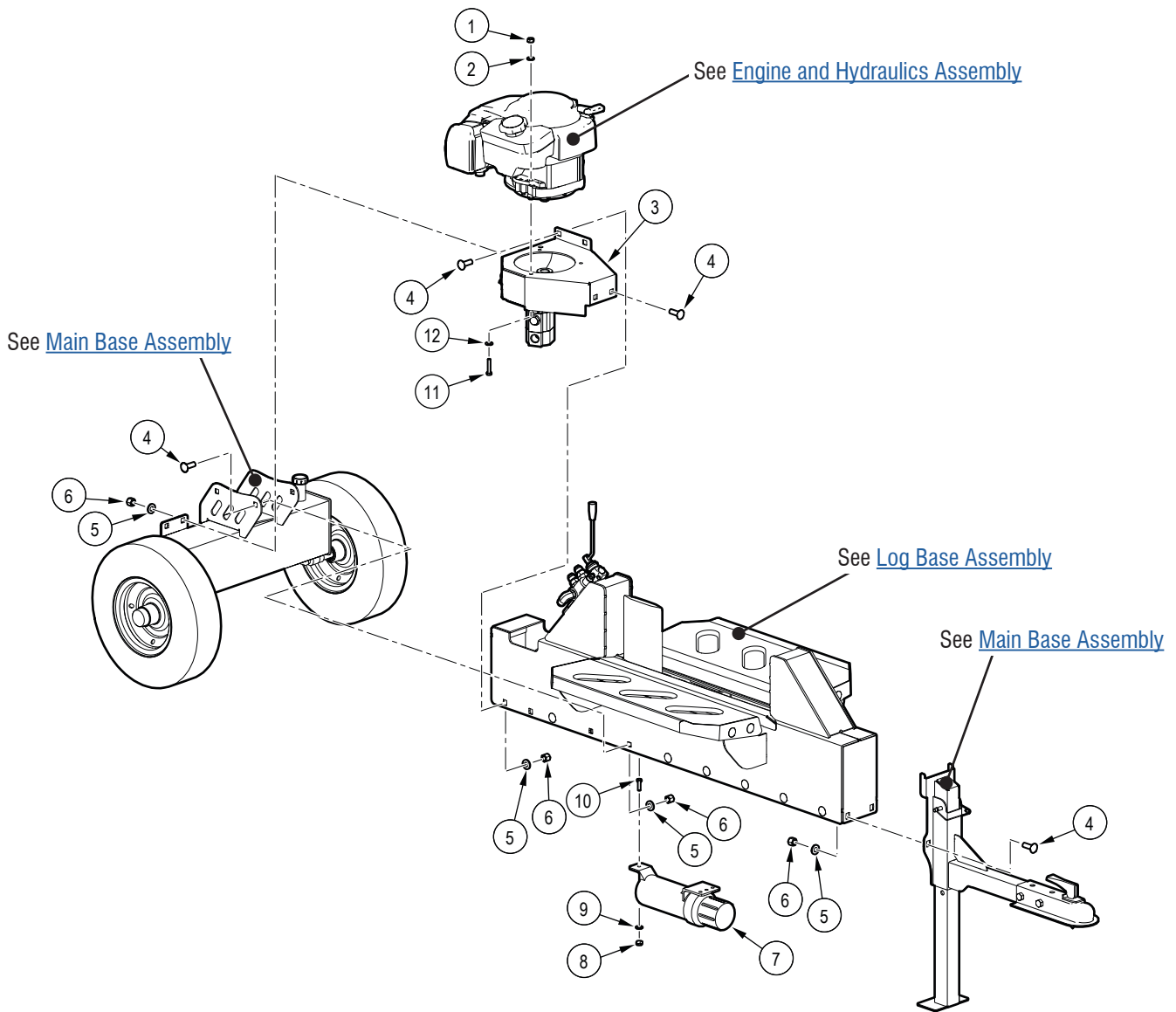

Item	Part number	Description	Quantity
1	Z77253	Hex Lock Nut, M8x1.25	3
2	Z77361	DIN 125 Washer, M10	6
3	2074W016	Motor Mount - Pump Mount, Weldment	1
4	Z76251	Carriage Bolt, 1/2NC x 1-1/2"	10
5	Z73151G8	SAE Washer, 1/2" Grade 8	10
6	Z72251	Hex Lock Nut, 1/2NC	10

Item	Part number	Description	Quantity
7	Z96503	Manual Tube, 3-1/2" Short	1
8	Z72221	Hex Lock Nut, 5/16NC	1
9	Z73122G8	SAE Washer, 5/16" Grade 8	1
10	Z79132	Weld Screw, 5/16NC x 5/8"	1
11	Z77156	Hex Bolt, M8x1.25 x 75mm	3

Log Base Assembly

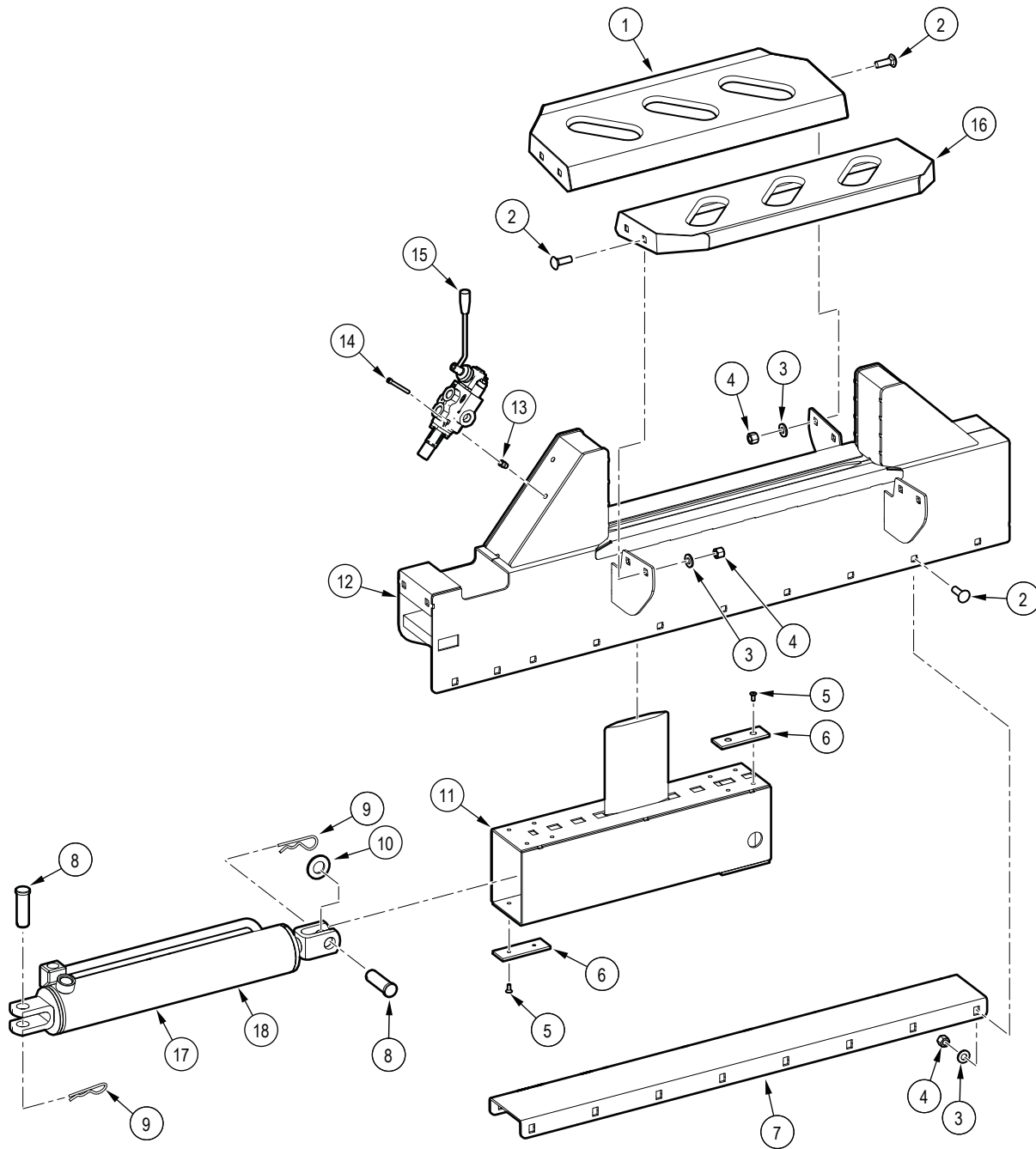

Item	Part number	Description	Quantity
1	2074W017	Table Weldment, LH	1
2	Z76251	Carriage Bolt, 1/2NC x 1-1/2"	12
3	Z73151G8	SAE Washer, 1/2" Grade 8	12
4	Z72251	Hex Lock Nut, 1/2NC	12
5	Z75213	FHCS, 1/4NC x 5/8"	16
6	2074S002	Low Friction Slider	8
7	2074W019	Rail Bottom, Weldment	1
8	2074M108	Clevis Pin, 1144SP, 1" x 3", 2-5/8" Usable	2
9	Z12245	Hitch Pin Clip, 11/64" x 3-3/4"	2

Item	Part number	Description	Quantity
10	Z73191G8	SAE Washer, 1" Grade 8	2
11	2074W011	Knife Slider Weldment	1
12	2074W003	Linear Rail Weldment	1
13	Z72962	Rivet Nut, 1/4NC x 260	2
14	Z75117	SHCS, 1/4NC x 2-1/4"	2
15	2074L007	Linear Bearing, Bottom	1
16	2074W018	Table Weldment, RH	1
17	2074C001	Cylinder, 3.5 x 18 x 1-1/4	1
18	SLK-3515	Seal Kit, 3-1/2" x 1-1/2" (not shown)	1

Main Base Assembly

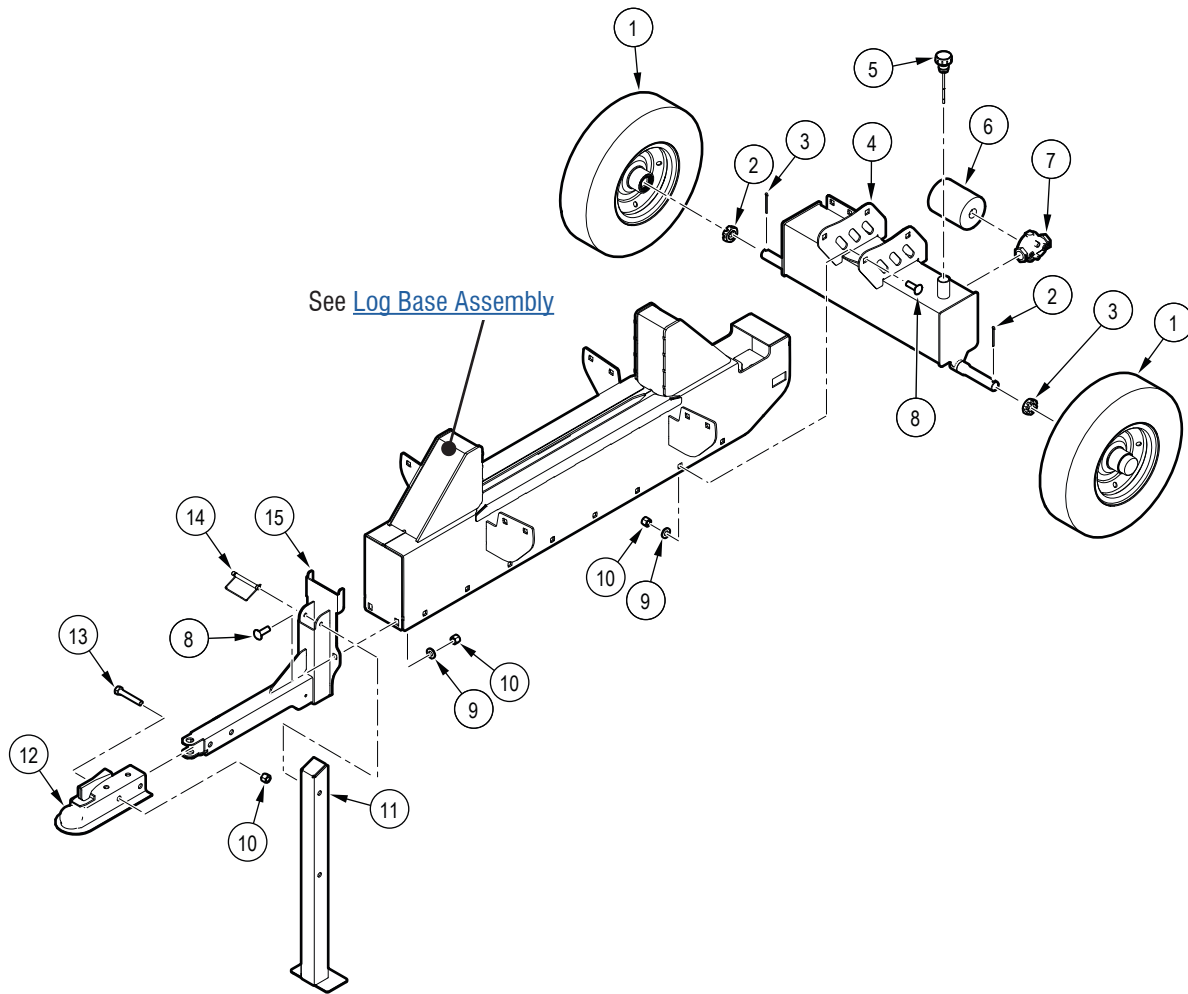

Item	Part number	Description	Quantity
1	Z91334	4.80-8 LRB 6PR 1" Bearing	2
2	Z72691	Castle Nut, 1NF x 9/16" Thick	2
3	Z12341	Cotter Pin, 5/32" x 2"	2
4	2074W005	Weldment, Tank	1
5	Z55402	Vented Plug Dipstick x 5"	1
6	Z55301	Particulate Filter, FP12	1
7	Z55302	Filter Cap, MP12 x FP12	1
8	Z76251	Carriage Bolt, 1/2NC x 1-1/2"	6

Item	Part number	Description	Quantity
9	Z73151G8	SAE Washer, 1/2" Grade 8	6
10	Z72251	Hex Lock Nut, 1/2NC	8
11	2074L166	Leg	1
12	Z91614	Hitch Coupler, 2" Ball x 2" x 3500lbs	1
13	Z71530	Hex Bolt, 1/2NC x 3"	2
14	Z12433	Snap Lock Pin, 3/8" x 3"	1
15	2074W115	Tongue, Weldment	1

Engine and Hydraulics Assembly

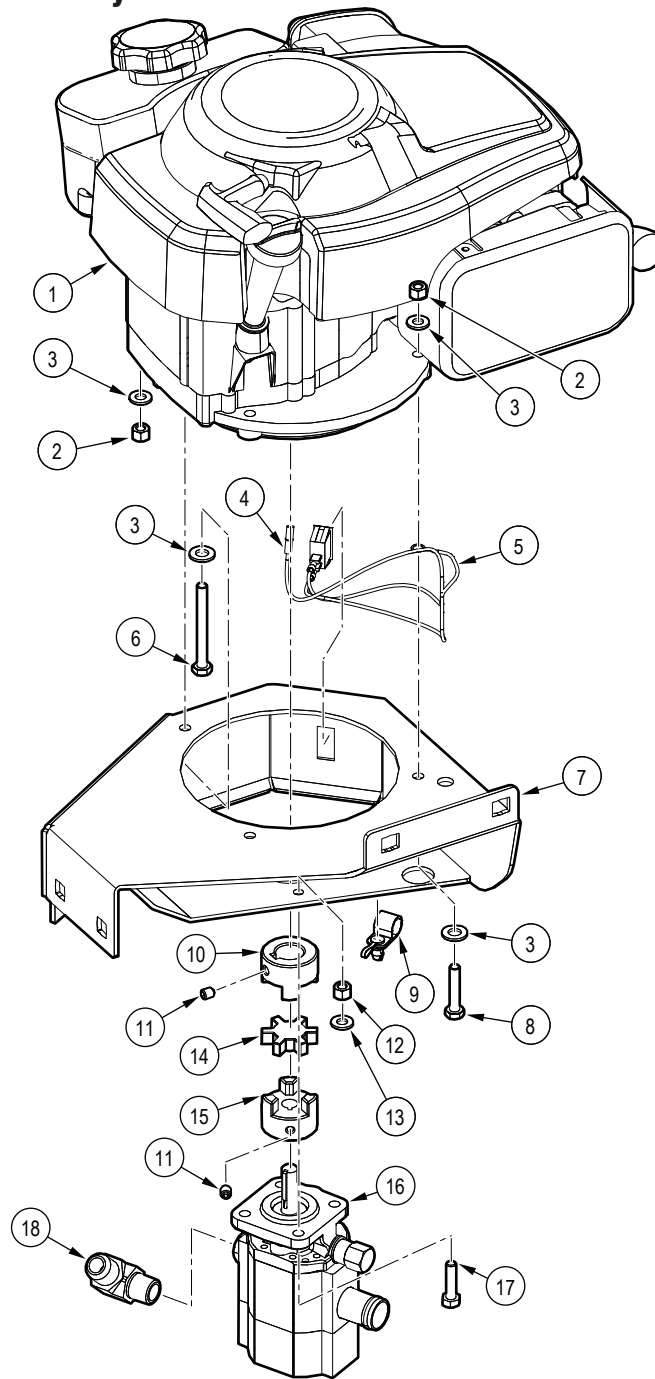

Item	Part number	Description	Quantity
1	Z47766	Briggs 5.8hp (190 cc) Engine	1
2	Z77253	Hex Lock Nut, M8x1.25	3
3	Z77361	DIN 125 Washer, M10	6
4	2074F009	WXT15V Switch Wire	1
5	2074F010	Ground wire	1
6	Z77156	Hex Bolt, M8x1.25 x 75mm	1
7	2074W016	Motor Mount - Pump Mount, Weldment	1
8	Z77151	Hex Bolt, M8x1.25 x 40mm	2
9	Z62828	Cable Clamp, P-Type Push In 1/2"	1

Item	Part number	Description	Quantity
10	Z46433	Shaft Coupling, L075 x 7/8" w/ 3/16" Keyway	1
11	Z74121	Set Screw, 5/16NC x 3/8"	2
12	Z72221	Hex Lock Nut, 5/16NC	4
13	Z73122G8	SAE Washer, 5/16" Grade 8	8
14	Z46408	Spider, L075	1
15	Z46410	Shaft Coupling, L075 x 1/2"	1
16	Z53204	Two-Stage Pump, 11GPM	1
17	Z71212	Hex Bolt, 5/16NC x 1-1/4"	4
18	Z514503	Elbow 90, MJIC x MP 1008	1

Valve Assembly

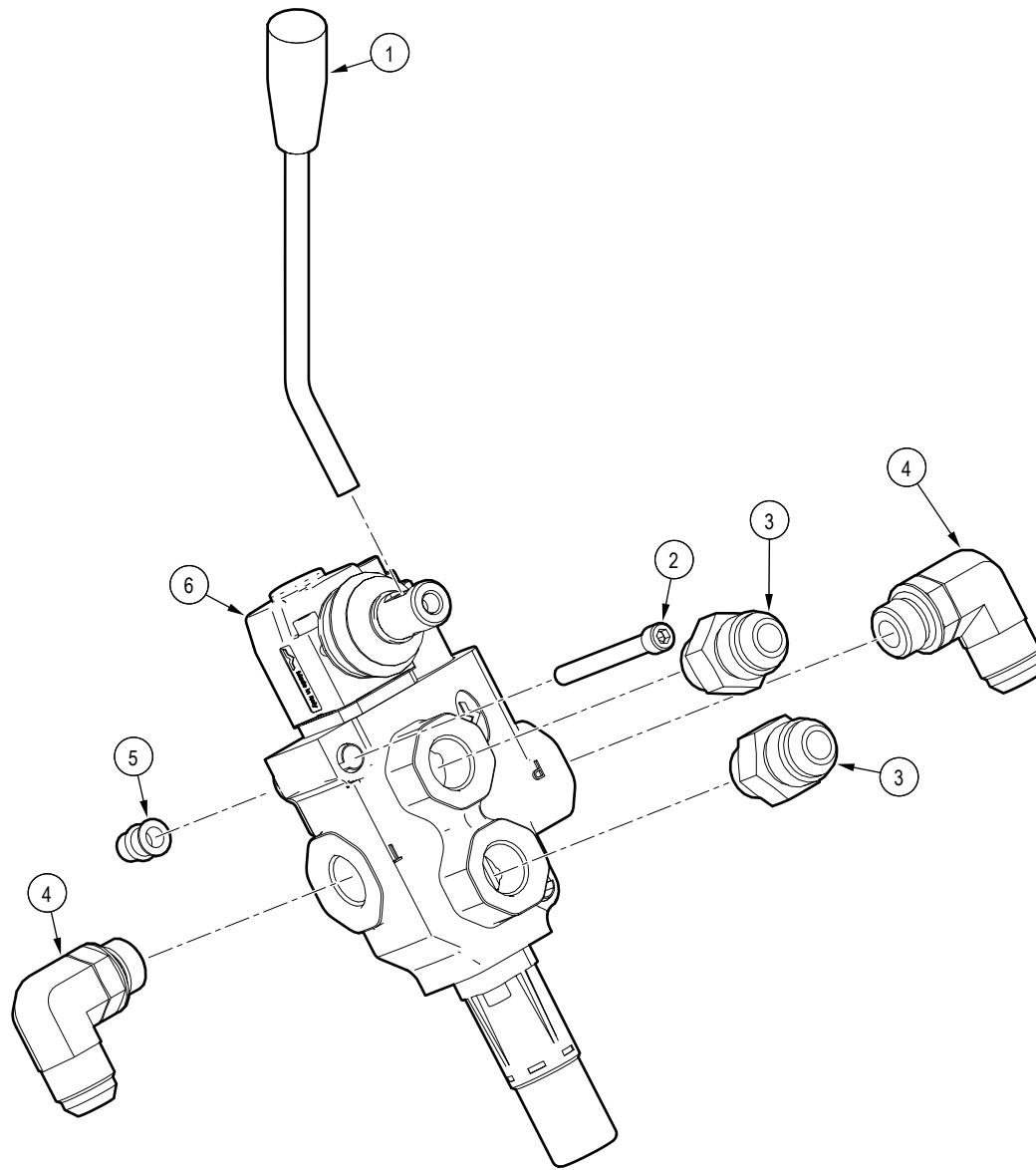

Item	Part number	Description	Quantity
1	2074M109	40 Degree Handle	1
2	Z75117	SHCS, 1/4NC x 2-1/4"	2
3	Z516423	Straight, MJIC x MORB 1008	2

Item	Part number	Description	Quantity
4	Z516510	Elbow 90, MJIC x MORB 1008	2
5	Z72962	Rivet Nut, 1/4NC x 260	2
6	Z56223-M	Single Spool Valve	1

Hydraulic Circuit

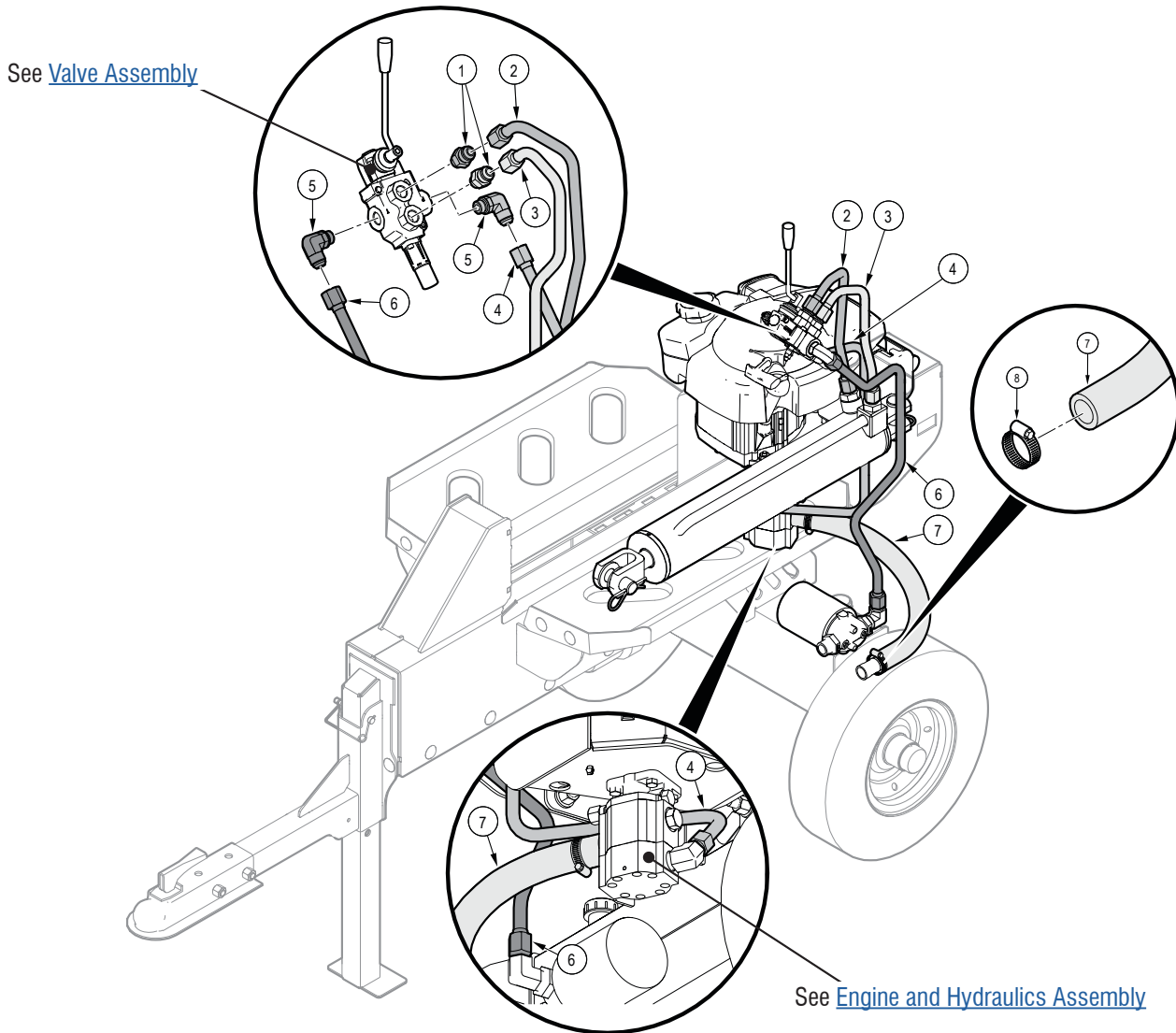

Item	Part number	Description	Quantity
1	Z516423	Straight, MJIC x MORB 1008	2
2	2074F003	5/8" Tube, FJIC10 x FJIC10	1
3	2074F001	5/8" Tube, FJIC10 x FJIC10	1
4	2074F005	5/8" Tube, FJIC10 x FJIC10	1

Item	Part number	Description	Quantity
5	Z516510	Elbow 90, MJIC x MORB 1008	2
6	2074F004	5/8" Tube, FJIC10 x FJIC10	1
7	2074F006	Suction Hose, 1" x 22"	1
8	Z79401	Hose Clamp, SAE 16 (1-1/2")	2

Label Locations

IMPORTANT! If you replace a part that has a safety label on it, you must apply a new safety label. Immediately replace safety labels that are damaged, have been removed, or are illegible.

Contact your local Wallenstein Equipment dealer or distributor to order a safety label kit. Labels are not sold individually.

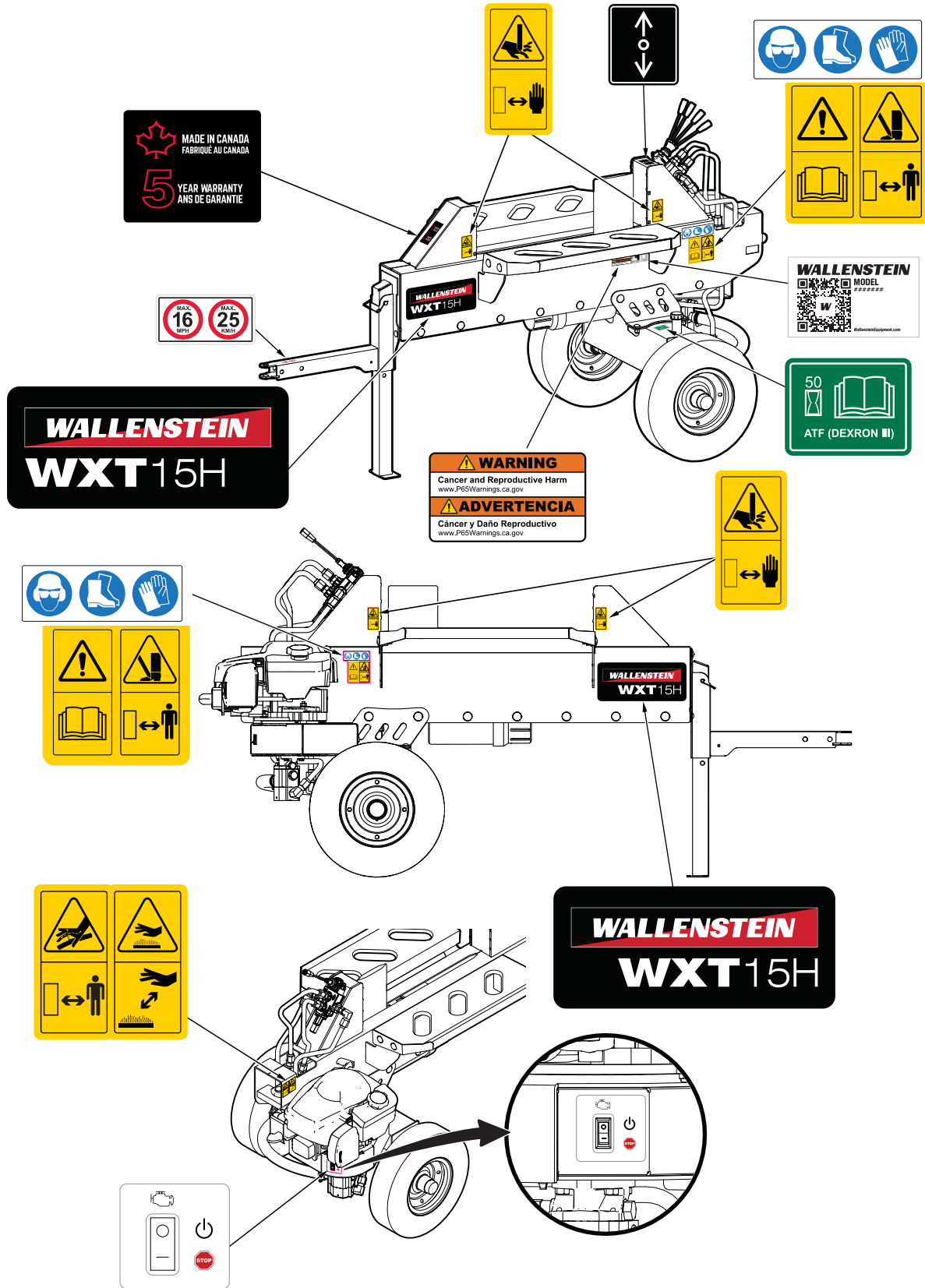

Accessories

For price and availability, contact your local Wallenstein dealer or go to WallensteinEquipment.com.

For accessory installation instructions, go to WallensteinEquipment.com/Support.aspx, and then select **Accessories**.

Bolt Torque

IMPORTANT! If you replace hardware, use fasteners of the same grade.

IMPORTANT! The torque specifications in these tables are for non-greased or non-oiled threads. Do not grease or oil fastener threads unless otherwise indicated. When using a thread lock, increase the specified torque 5%.



Bolt grades are identified by the marks on the bolt head.

The bolt torque specification tables provide the correct torque settings for common bolts and capscrews. Tighten all bolts to the torque that is specified in the table, unless otherwise indicated. Check the bolt tightness periodically.

Imperial Bolt Torque Specifications

Bolt Diameter	Torque					
	SAE Gr. 2		SAE Gr. 5		SAE Gr. 8	
	lbf•ft	N•m	lbf•ft	N•m	lbf•ft	N•m
1/4 inch	6	8	9	12	12	17
5/16 inch	10	13	19	25	27	36
3/8 inch	20	27	33	45	45	63
7/16 inch	30	41	53	72	75	100
1/2 inch	45	61	80	110	115	155
9/16 inch	60	95	115	155	165	220
5/8 inch	95	128	160	215	220	305
3/4 inch	165	225	290	390	400	540
7/8 inch	170	230	420	570	650	880



SAE Gr. 2



SAE Gr. 5



SAE Gr. 8

Metric Bolt Torque Specifications

Bolt Diameter	Torque			
	Gr. 8.8		Gr. 10.9	
	lbf•ft	N•m	lbf•ft	N•m
M3	0.4	0.5	1.3	1.8
M4	2.2	3	3.3	4.5
M6	7	10	11	15
M8	18	25	26	35
M10	37	50	52	70
M12	66	90	92	125
M14	83	112	116	158
M16	166	225	229	310
M20	321	435	450	610
M30	1,103	1,495	1,550	2,100



8.8



10.9

Hydraulic Fitting Torque

Tighten flare-type tube fittings:

1. Check the flare and flare seat for defects that might cause leaks.
2. Align the tube with the fitting before tightening.
3. Hand-tighten the swivel nut until it is snug.
4. To prevent the tube from twisting, use two wrenches. Place one wrench on the connector body and tighten the swivel nut with the second wrench. Torque the fitting to the correct specification.

If a torque wrench is not available, use the flats from finger tight (FFFT) method.

Hydraulic Fitting Torque Specifications					
Tube size OD	Hex size across flats	Torque		Flats from finger tight	
		lbf•ft	N•m	Flats	Turns
3/16	7/16	6	8	2	1/6
1/4	9/16	11–12	15–17	2	1/6
5/16	5/8	14–16	19–22	2	1/6
3/8	11/16	20–22	27–30	1-1/4	1/6
1/2	7/8	44–48	59–65	1	1/6
5/8	1	50–58	68–79	1	1/6
3/4	1-1/4	79–88	107–119	1	1/8
1	1-5/8	117–125	158–170	1	1/8

Specifications are for non-lubricated connections.



MAKING WORK FEEL MORE LIKE PLAY™

WallensteinEquipment.com

