

WALLENSTEIN

EMB Manufacturing Inc.
4144 Boomer Line · St. Clements, On · N0B 2M0 · Canada
Ph: (519) 699-9283 · Fax: (519) 699-4146
www.wallensteinequipment.com

WX450 Skidsteer Splitter Parts Manual

S/N 190001 & After



Refer to the operators
manual for safe
operation and
maintenance

2034 WX450 RevC2 Parts Manual.110511

170516

Foreword

EMB Mfg. has prepared this parts manual to assist customers in ordering quality OEM replacement parts.

Proper and regular service and replacing old, worn or broken parts with the correct OEM parts are essential to prolonging the life of your EMB product. Please refer to this manual before ordering any replacement parts.

All information contained in this parts manual is based on the latest product specification available at the time of printing this manual. If your product differs from the specifications contained within this manual contact EMB Mfg. for information.

EMB reserves the right to alter specifications on their products at any time.

Reproduction of this parts manual of any kind is prohibited without prior written permission from EMB Mfg.

Table of Contents

Bolt Torque	4
Hydraulic Fitting Torque	5
Cylinder	6
Main Parts	7
Valve Assembly	9
Decal Breakdown	10

Bolt Torque

CHECKING BOLT TORQUE

The tables shown below give correct torque values for various bolts and capscrews. Tighten all bolts to the torques specified in chart unless otherwise noted. Check tightness of bolts periodically, using bolt torque chart as a guide. Replace hardware with the same strength bolt.

ENGLISH TORQUE SPECIFICATIONS						
Bolt Diameter "A"	Bolt Torque*					
	SAE 2 (N.m) (lb-ft)		SAE 5 (N.m) (lb-ft)		SAE 8 (N.m) (lb-ft)	
1/4"	8	6	12	9	17	12
5/16"	13	10	25	19	36	27
3/8"	27	20	45	33	63	45
7/16"	41	30	72	53	100	75
1/2"	61	45	110	80	155	115
9/16"	95	60	155	115	220	165
5/8"	128	95	215	160	305	220
3/4"	225	165	390	290	540	400
7/8"	230	170	570	420	880	650
1"	345	225	850	630	1320	970

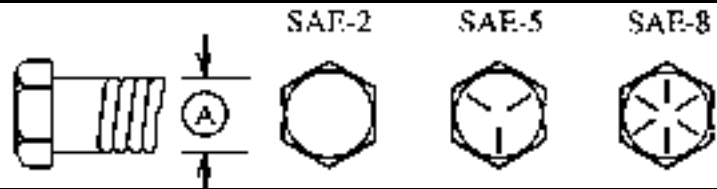

Torque figures indicated above are valid for non-greased or non-oiled threads and heads unless otherwise specified. Therefore, do not grease or oil bolts or capscrews unless otherwise specified in this manual. When using locking elements, increase torque values by 5%.

* Torque value for bolts and capscrews are identified by their head markings.

METRIC TORQUE SPECIFICATIONS				
Bolt Diameter "A"	Bolt Torque*			
	8.8 (N.m) (lb-ft)		10.9 (N.m) (lb-ft)	
M3	0.5	0.4	1.8	1.3
M4	3	2.2	4.5	3.3
M5	6	4	9	7
M6	10	7	15	11
M8	25	18	35	26
M10	50	37	70	52
M12	90	66	125	92
M14	140	103	200	148
M16	225	166	310	229
M20	435	321	610	450
M24	750	553	1050	774
M30	1495	1103	2100	1550
M36	2600	1917	3675	2710

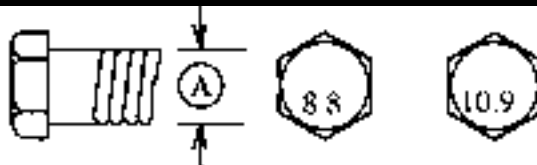

Hydraulic Fitting Torque**Tightening Flare Type Tube Fittings ***

1. Check flare and flare seat for defects that might cause leakage.
2. Align tube with fitting before tightening.
3. Lubricate connection and hand tighten swivel nut until snug.
4. To prevent twisting the tube(s), use two wrenches. Place one wrench on the connector body and with the second tighten the swivel nut to the torque shown.

Tube Size OD	Nut Size Across Flats	Torque Value*		Recommended Turns To Tighten (After Finger Tightening)	
		(N.m)	(lb-ft)	(Flats)	(Turn)
3/16	7/16	8	6	1	1/6
1/4	9/16	12	9	1	1/6
5/16	5/8	16	12	1	1/6
3/8	11/16	24	18	1	1/6
1/2	7/8	46	34	1	1/6
5/8	1	62	46	1	1/6
3/4	1-1/4	102	75	3/4	1/8
7/8	1-3/8	122	90	3/4	1/8

The torque values shown are based on lubricated connections as in reassembly.

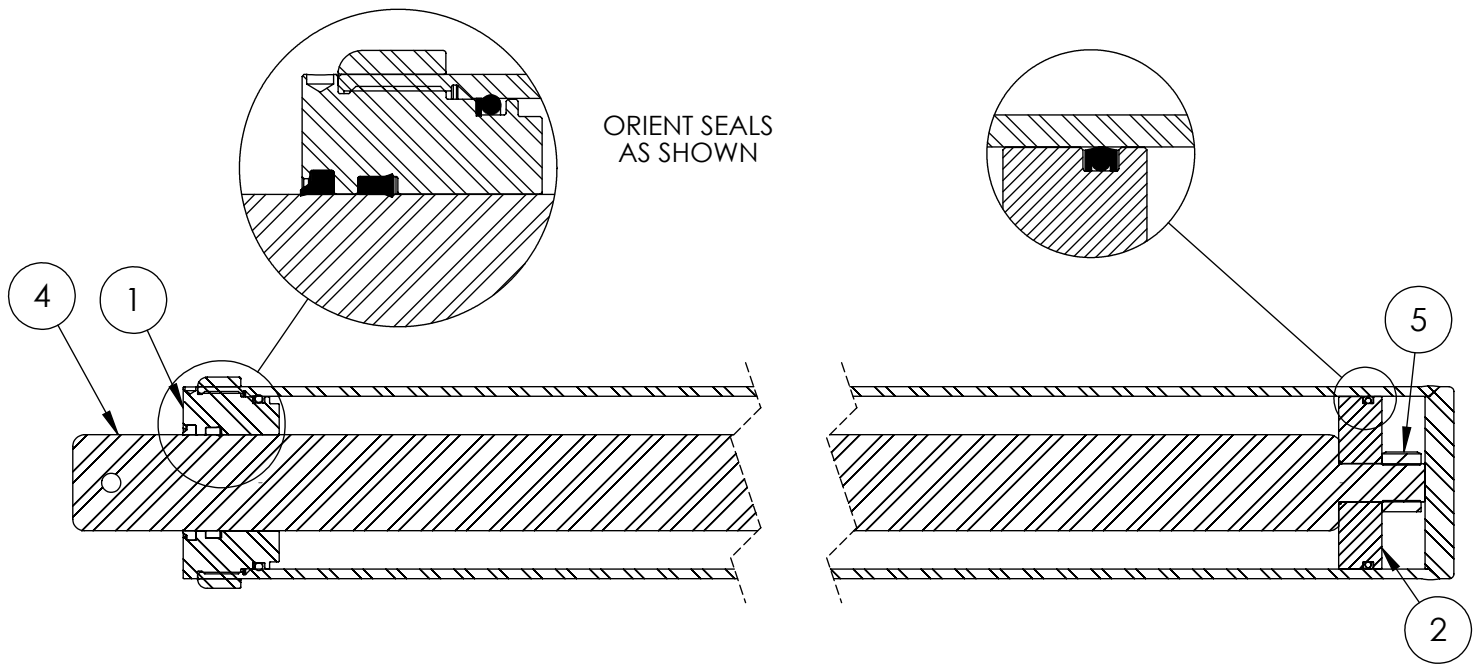

4-1/2" x 36" STROKE CYLINDER PARTS

ITEM	PART NO.	DESCRIPTION	QTY
1	G450-250SA	4-1/2" Bore x 2-1/2" Rod Gland With Seals	1
2	P100-450SA	4-1/2" Bore Piston With Seals	1
3	2032C2011	Barrel, 4-1/2"	1
4	2032C2013	Rod, 2-1/2x 1	1
5	Z72292G8	Hex Lock Nut 1NF Grade 8	1
6	SLK-4525	Seal Kit, 4-1/2 x 2-1/2	1

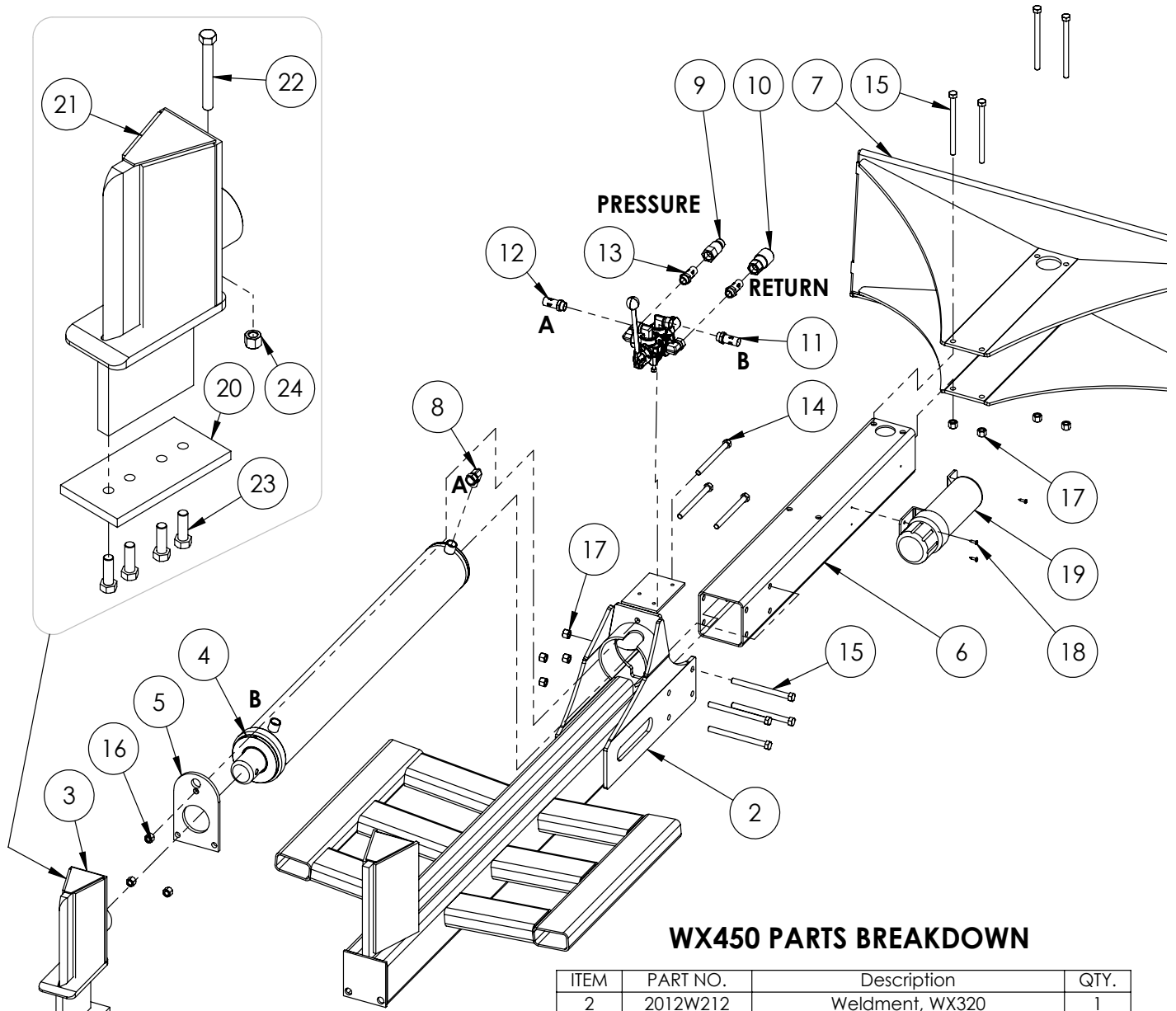

WX450 PARTS BREAKDOWN

ITEM	PART NO.	Description	QTY.
2	2012W212	Weldment, WX320	1
3	2032A202	Wedge, Large Sliding Assy	1
4	2032C201	Cylinder, 4-1/2 x 36 x 2-1/2	1
5	2032S213	Plate, Cylinder Retaining	1
6	2032S214	Tube, WX430	1
7	2032W206	Weldment, Skidsteer Mount Plate	1
8	Z51331	Elbow 90 MP x FPX 0808	1
9	Z51919	Flat-Face,FP08 x Male ISO16028	1
10	Z51920	Flat Face FP08 x Fem ISO 16028	1
11	Z52301	1/2 Hose MP08 x MP08 x 16"	1
12	Z52303	1/2 Hose,1/2MP x 1/2MP x 36"	1
13	Z52312	1/2 Hose, 1/2MPx1/2MPx 96"	2
14	Z71560	Hex Bolt 1/2NC x 6	3
15	Z71565	Hex Bolt, 1/2NC x 6-1/2	8
16	Z72251	Hex Lock Nut 1/2NC	3
17	Z72251	Hex Lock Nut 1/2NC	8
18	Z76721	Self-tapping Screw	3
19	Z96503	Manual Tube 3-1/2 Short	1
ITEM	PART NO.	Description	QTY.
20	2014S414	Plate, Sliding Wedge Capture	1
21	2032W203	Wedge, Large Sliding	1
22	Z71540	Hex Bolt 1/2NC x 4	1
23	Z71576	Hex Bolt 1/2NF x 1-1/2	4
24	Z72251	Hex Lock Nut 1/2NC	1

This Page is Intentionally Blank

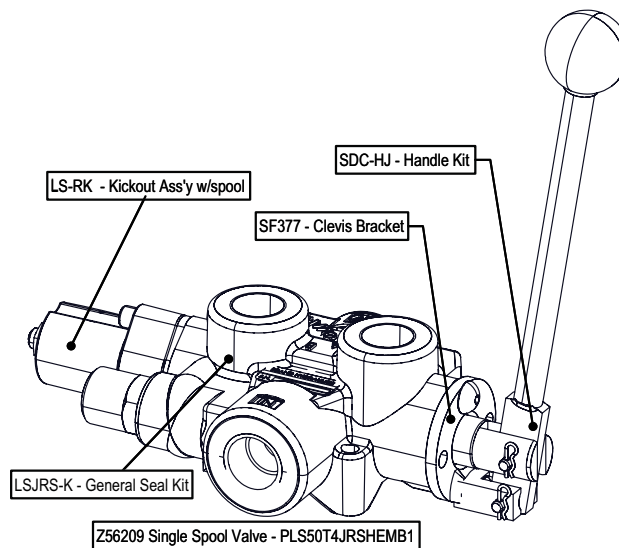
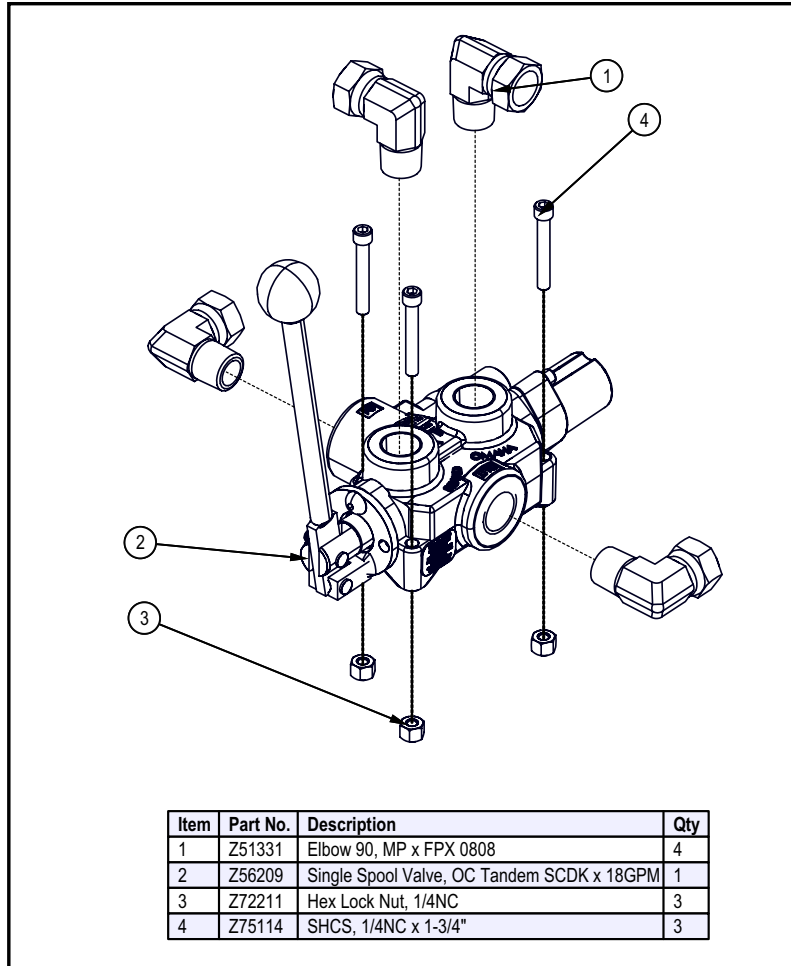

Z56209 Valve Kits

TWO PANEL WX450 DECAL BREAKDOWN

ITEM	PART NO.	DESCRIPTION	QTY
1	Z94119	CAUTION - Read Manual	1
2	Z94123	Keep Feet Back	1
3	Z94067	Clear Guide	2
4	Z94056	Wallenstein	2
5	Z94019	Made in Canada	4
6	Z94124	Keep Hands Back	1

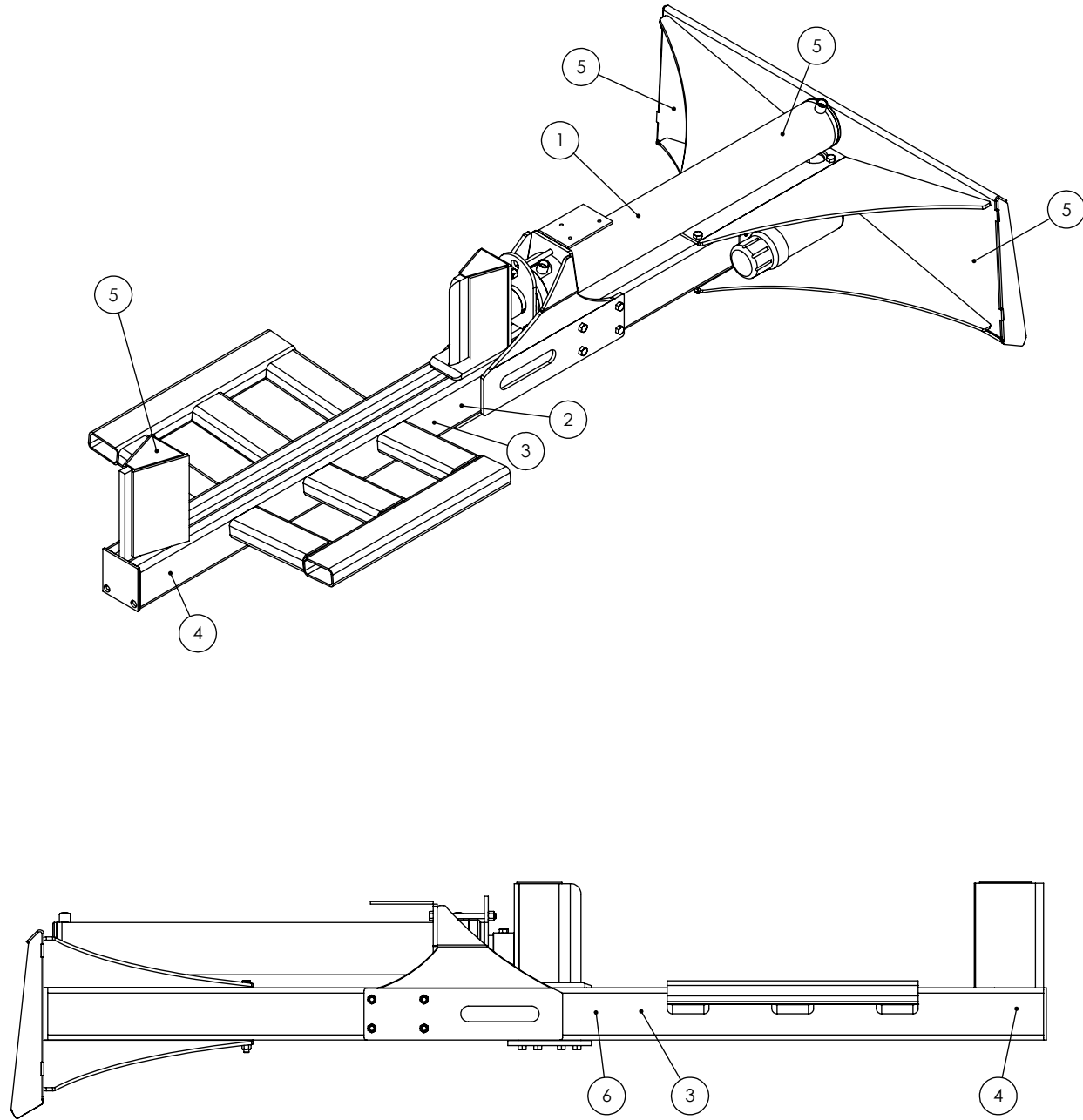

Two Panel Skidsteer Splitter Decals

Z94019



Z94067



Z94056



Z94119



Z94123



Z94124



