

# OPERATOR'S MANUAL

---

CT24 – S/N CT244 & Up

## CT24 Trailer Firewood Conveyor

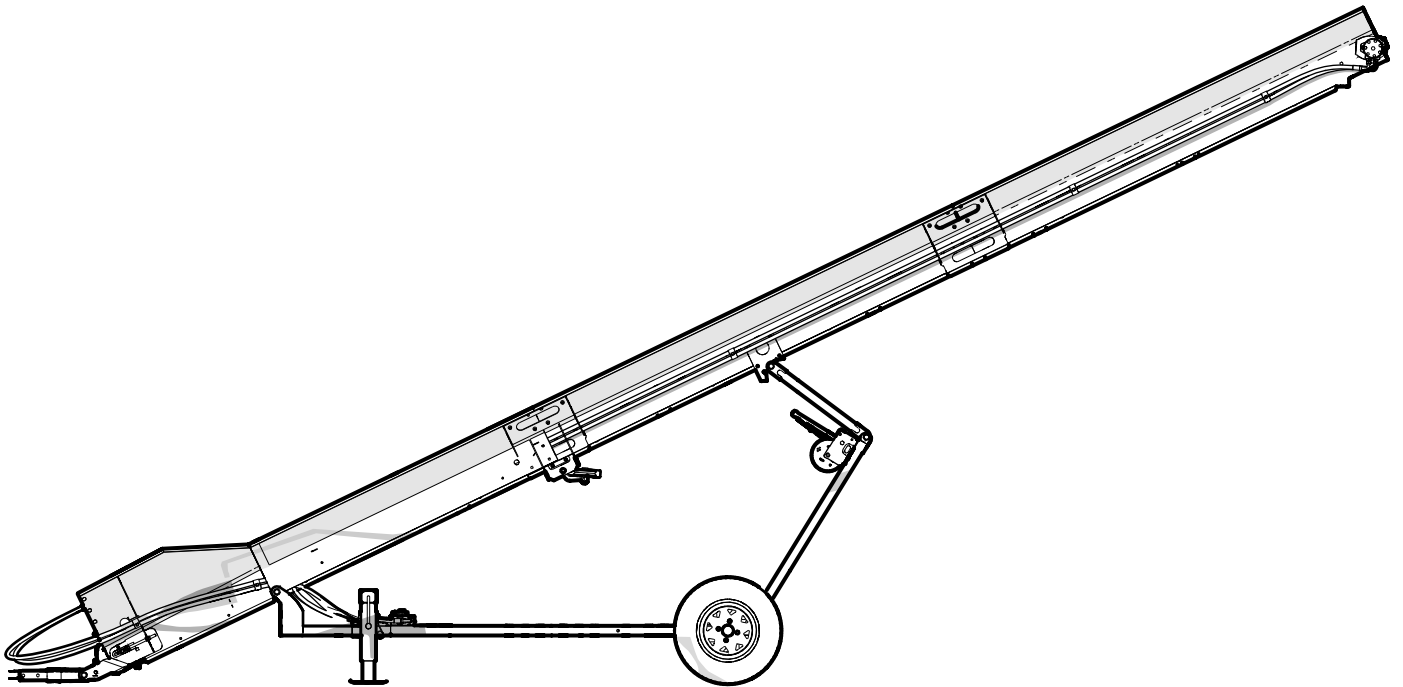

---

Rev Feb-2022

Part Number: Z97163\_En

**WALLENSTEIN**

# 1. Foreword

## 1.1 Introduction

Congratulations on choosing a **Wallenstein CT Series Trailer Firewood Conveyor!**

This manual covers Wallenstein CT24 trailer conveyor. This high-quality machine is designed and manufactured to meet the needs of a proficient timber or woodlot industry.

The Wallenstein CT24 conveyor is built to compliment the Wallenstein wood processors and splitters. This 24 ft (7.3 m) hydraulic conveyor features tension-adjustable, heavy-duty 662 chain. The conveyor requires an external hydraulic power source of 3 US gpm (11.3 Lpm) at 3000 psi (207 bar). An accessory hydraulic power pack is available to mount onto the conveyor frame in the event an external power source is not available.

Wallenstein conveyors provide fast and efficient means of moving and stockpiling large quantities of split wood. Wheels can be rotated 90 degrees to reposition as the split stack pile builds up.

Safe, efficient, and trouble-free operation Wallenstein products requires that anyone using or maintaining the machine reads and understands the Safety, Operation, Maintenance information contained within this Operator's Manual.

Units of measurement in Wallenstein Equipment technical manuals are written as:  
US Customary (SI metric).

Keep this manual handy for frequent reference and to pass on to new operators or owners. Call your Wallenstein dealer or distributor if you need assistance, information, or additional copies of the manuals.



### WARNING!

**Do not attempt to start or operate the machine without thoroughly reviewing this manual for safe and proper operation.**

**Always keep this manual with the machine.**

W034

**Wallenstein Equipment Inc. • © 2022. All rights reserved.**

No part of this work may be copied, reproduced, replaced, distributed, published, displayed, modified, or transferred in any form or by any means except with the prior permission of Wallenstein Equipment Inc.

## Table of Contents

<b>1. Foreword</b> .....	<b>2</b>
1.1 Introduction.....	2
1.2 Delivery Inspection Report.....	4
1.3 Serial Number Location .....	5
1.4 Types of Decals on the Machine .....	6
<b>2. Safety</b> .....	<b>7</b>
2.1 Safety Alert Symbol.....	7
2.2 Signal Words.....	7
2.3 Why is SAFETY important? .....	7
2.4 Safety Rules.....	8
2.5 Operating Safety.....	8
2.6 Equipment Safety Guidelines .....	9
2.8 Safety Sign Explanations .....	11
2.9 Replacing Damaged Safety Signs .....	13
2.10 Sign-Off Form .....	14
<b>3. Familiarization</b> .....	<b>15</b>
3.1 To the New Operator .....	15
3.2 Training.....	15
3.3 Job Site Familiarization .....	15
3.4 Equipment Condition .....	15
3.5 Operator Orientation .....	15
3.6 Conveyor Components .....	16
<b>4. Conveyor Setup</b> .....	<b>17</b>
<b>5. Operating Instructions</b> .....	<b>19</b>
5.1 Break-in Period.....	19
5.2 Pre-Operation Checklist.....	19
5.3 Setting Conveyor Speed .....	20
5.4 Conveyor Height, Adjusting.....	20
5.5 Conveyor Angle Indicator.....	21
5.6 Rotating Wheels .....	22
5.7 Moving, Swinging the Conveyor Sideways .....	22
5.8 Conveyor Axle Position.....	23
5.9 Accessory Hydraulic Power Pack .....	24
5.10 Transporting.....	31
5.11 Storage.....	33
<b>6. Service and Maintenance</b> .....	<b>34</b>
6.1 Maintenance Safety.....	34
6.2 Maintenance Schedule .....	34
6.3 Grease Points.....	35
6.4 Conveyor Chain Tension, Adjusting.....	35
6.5 Hand Winch .....	36
6.6 Accessory Power Pack.....	36
<b>7. Troubleshooting</b> .....	<b>39</b>
<b>8. Specifications</b> .....	<b>40</b>
8.1 Machine Specifications.....	40
8.2 Common Bolt Torque Values .....	41
8.3 Wheel Lug Torque .....	42
<b>9. Product Warranty</b> .....	<b>43</b>
<b>10. Alphabetical Index</b> .....	<b>44</b>

# 1.2 Delivery Inspection Report

This form must be filled out by the dealer at the time of delivery, then signed by the dealer and customer.

## Wallenstein CT24 Trailer Firewood Conveyor

To activate warranty, register your product at:  
[www.wallensteinequipment.com](http://www.wallensteinequipment.com)

The product manuals have been received by me and I have been thoroughly instructed as to care, adjustments, safe operation, and applicable warranty policy.

I have thoroughly instructed the buyer on the equipment care, adjustments, safe operation, applicable warranty policy, and have reviewed the manuals.

\_\_\_\_\_

Customer

\_\_\_\_\_

Address

\_\_\_\_\_

City, State/Province, ZIP/Postal Code

(        )

\_\_\_\_\_

Phone Number

\_\_\_\_\_

Contact Name

\_\_\_\_\_

Model

\_\_\_\_\_

Serial Number

\_\_\_\_\_

Delivery date

\_\_\_\_\_

Dealer

\_\_\_\_\_

Address

\_\_\_\_\_

City, State/Province, ZIP/Postal Code

(        )

\_\_\_\_\_

Phone Number

### 1.2.1 Dealer Inspection Report

- \_\_\_\_\_ All Fasteners Tight
- \_\_\_\_\_ Conveyor Drive Lubricated
- \_\_\_\_\_ Pivot Tongue Moves Freely
- \_\_\_\_\_ Review Operating and Safety Instructions

#### Safety Checks

- \_\_\_\_\_ All Safety Decals Installed
- \_\_\_\_\_ Guards and Shields Installed and Secured
- \_\_\_\_\_ Check Crank Jack Function
- \_\_\_\_\_ Tire Pressure Correct
- \_\_\_\_\_ Wheel Lug Torque Checked

### 1.3 Serial Number Location

Always provide the model and serial number of your Wallenstein product when ordering parts or requesting service or other information. This information is found on the serial number plate shown in the illustration below.

**Record product information in the spaces provided for future reference.**

Record Product Information Here	
Model:	
Serial Number:	

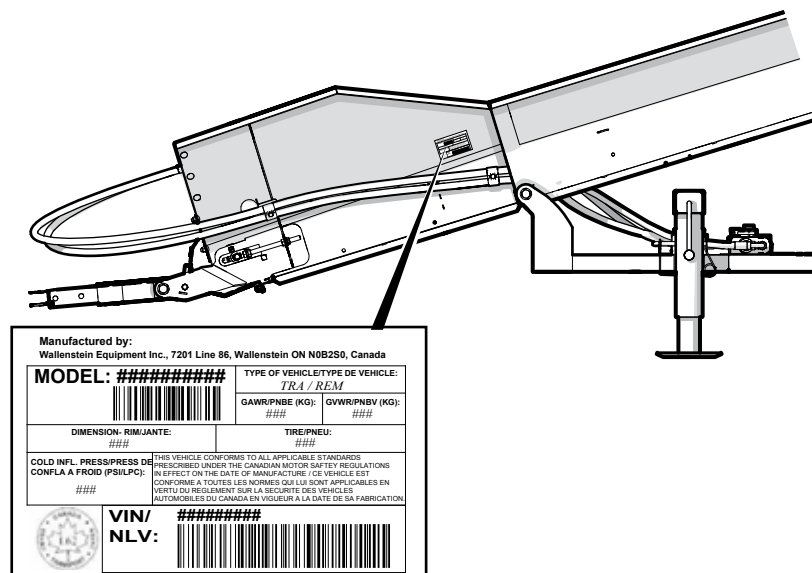
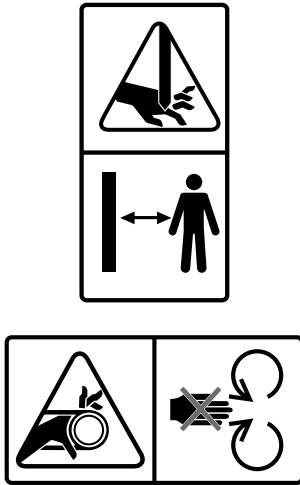

Fig. 1 – Serial Number Plate Location

## 1.4 Types of Decals on the Machine

When getting familiar with the Wallenstein product, notice that there are numerous decals located on the machine. There are different types of decals for safety, information, and product identification. The following section explains what they are for and how to read them.

**Safety Decals** have a yellow background and have two panels. They can be either vertical or horizontal.



**Safety Notice Decals** are blue with a white background and rectangular with single or multiple symbols. This decal informs what Personal Protective Equipment is required for safe operation.



**Informative Decals** are pictorial with a white background and can vary in the number of panels. This type of decal provides additional information to the operator or explains the operation of a control.

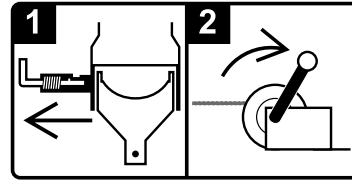

**Product Decals** indicate machine model and serial number, and other important information.



**Maintenance Decals** have a green background and can vary to the number of panels. This decal shows the maintenance required and frequency interval.

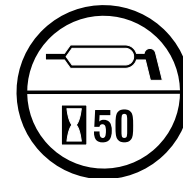

See the section on safety signs for safety decal definitions. For a complete illustration of decals and decal locations, download the parts manual for your model product at [www.wallensteinequipment.com](http://www.wallensteinequipment.com).

## 2. Safety

### 2.1 Safety Alert Symbol

This Safety Alert Symbol means:

**ATTENTION! BE ALERT!**  
**YOUR SAFETY IS INVOLVED!**

The **Safety Alert Symbol** identifies important safety messages on the Wallenstein conveyor and in the manual. When you see this symbol, be alert to the possibility of personal injury or death. Follow the instructions in the safety message.



### 2.2 Signal Words

The signal words **DANGER**, **WARNING** and **CAUTION** determine the seriousness level of the warning messages in this manual. The appropriate signal word for each message in this manual has been selected using the following guidelines:

#### **DANGER –**

Indicates an imminently hazardous situation that, if not avoided, **will** result in death or serious injury. This signal word is to be limited to the most extreme situations typically for machine components which, for functional purposes, cannot be guarded.

#### **WARNING –**

Indicates a potentially hazardous situation that, if not avoided, **could** result in death or serious injury, and includes hazards that are exposed when guards are removed. It may also be used to alert against unsafe practices.

#### **CAUTION –**

Indicates a potentially hazardous situation that, if not avoided, **may** result in minor or moderate injury. It may also be used to alert against unsafe practices.

**IMPORTANT** – To avoid confusing equipment protection with personal safety messages, a signal word **IMPORTANT** indicates a situation that if not avoided, could result in damage to the machine.

### 2.3 Why is SAFETY important?

#### **Three Big Reasons:**

- **Accidents can disable and kill**
- **Accidents can cause financial hardship**
- **Accidents can be avoided**

**YOU** are responsible for the **SAFE** operation and maintenance of your Wallenstein trailer conveyor. **YOU** must ensure that you and anyone else who is going to use, maintain or work around the conveyor be familiar with the operating and maintenance procedures and related **SAFETY** information contained in this manual. This manual provides good safety practices that should be followed while using this machine.

Remember, **YOU** are the key to safety. Good safety practices not only protect you but also the people around you. Make these practices a working part of your safety program. Be certain that **EVERYONE** using this equipment is familiar with the recommended operating and maintenance procedures and follows all the safety precautions. Most accidents can be prevented.

**Do not risk injury or death by ignoring good safety practices.**

## 2.4 Safety Rules

- Anyone who is going to use this machine must read and understand all safety and operating instructions beforehand.
- Always wear appropriate Personal Protective Equipment (PPE). This equipment includes but is not limited to:
  - A hard hat
  - Heavy gloves
  - Hearing protection
  - Protective shoes with slip resistant soles
  - Protective glasses, goggles, or face shield



- Read and understand ALL Safety and Operating instructions in the manual and follow them. Most accidents can be avoided. The most important safety device on this equipment is a SAFE operator.
- Be sure you understand all safety signs located on the machine before using, maintaining, adjusting, or cleaning.
- Inspect and secure all guards before starting.
- Place the machine in a Safe Condition before performing any service, maintenance work, storage preparation, or hooking up.

Placing the machine in a Safe Condition involves performing the following:

SAFE CONDITION
<ol style="list-style-type: none"> <li>1. Unload the conveyor.</li> <li>2. Shut off the engine. Disconnect spark plug leads. Disconnect negative (-) battery cable from battery.</li> <li>3. Lower the conveyor fully until it is resting on the stops.</li> </ol>

- Have a first-aid kit available for use should the need arise.



- Always keep a fire extinguisher available for use should the need arise and know how to use it.



- Check the machine is clear of debris prior to starting the engine.
- Review safety related items annually with all personnel who will be operating or performing maintenance.
- Do not expect a person who does not understand operation and safety instructions to use the machine. Untrained operators are not qualified and can create risks of serious injury or death. It is the machine owner's responsibility to make sure every operator is fully trained.
- Do not modify the equipment in any way. Unauthorized modification may impair function or safety, could affect the life of the equipment, and can void warranty.
- Never allow riders during transport.
- Do not risk injury or death by ignoring good safety practices.
- **Think SAFETY! Work SAFELY!**

### 2.4.1 Safety Training

- Safety is a primary concern in the design and manufacture of Wallenstein products. Unfortunately, our efforts to provide safe equipment can be wiped out by a single careless act.
- The best safety feature is an informed, careful operator—we ask you to be that kind of an operator. It is the operator's responsibility to read, understand and follow ALL safety and operation instructions in the manual. Accidents can be avoided.



- **Do not allow anyone to use this machine until they have read this manual. Operator's must have a thorough understanding of the safety precautions and of how the machine works.** Review the safety instructions with all users annually.

## 2.5 Operating Safety

It is important that you read and pay attention to the safety signs on the machine. Clean or replace all safety signs if they cannot be clearly read and understood. They are there for your safety, as well as the safety of others.



- Train all operators to be familiar with equipment operation. The operator should be a responsible, properly trained and physically able person familiar with machinery. If elderly people are assisting with work, their physical limitations need to be recognized and accommodated.
- Wear hearing protection on a full-time basis. Prolonged exposure to loud noise may cause permanent hearing loss!
  - Noise over 85 dB on a long-term basis can cause severe hearing loss.
  - Noise over 90 dB adjacent to the Operator over a long-term basis may cause permanent, total hearing loss.
- Keep bystanders at a safe distance at least 20 ft (6 m) away from the conveyor.
- Determine a proper conveyor location ahead of time:
  - Ground should be firm and level.
  - Area must be clear of stones, branches or hidden obstacles that might cause a tripping, hooking, or snagging hazard.
  - There must be no overhead hazards such as branches, cables, electrical wires and so on.
  - Stack split wood on level ground. Make sure split wood pile does not interfere with conveyor operation, wheel rotation.
- Operate in daylight or good artificial light only.
- Make sure machine is properly stationed, adjusted and in good operating condition.
- Do not operate on hillsides or when working area is cluttered, wet, muddy, or icy to prevent slipping and tripping. Keep working area clean and free of debris.
- Make sure all guards, deflectors and shields are installed before starting and operating the machine.
- Operate the machine only when physically fit and not under the influence of alcohol, drugs or medicines that can cause drowsiness.
- Avoid loose fitting clothing, loose or uncovered long hair, jewelry and loose personal articles. These can get caught in moving parts.
- Never walk under the conveyor. Split wood falling from the conveyor can cause serious injuries. Failure of the hoisting winch could cause the conveyor to lower unexpectedly.
- Do not climb on the conveyor. If maintenance or other work is required, avoid the risk of falling off by lowering it.



## 2.6 Equipment Safety Guidelines

- Replace any safety sign or instruction sign that is not readable or is missing. Location of such safety signs is indicated in this manual.
- Never exceed the limitations of the machine. If its ability to do the job, or to do it safely is in question—**STOP!**
- Always inspect the winch cable and its attachment before each use to make sure they are not damaged. Never use worn, kinked, or frayed cable. If the cable or attachment break, the cable can whip violently, causing serious bodily injury or death.
- Never stand alongside the winch cable or guide the cable with your hands.
- Never operate the conveyor winch with slippery, wet, or oily hands. Always maintain a firm grip on the winch handle. Do not attempt to stop a winch by grabbing the handle while in motion.
- Always maintain a minimum of three complete wraps of cable on the drum.
- Listen for a loud clicking sound from the ratchet when lifting the load. If a loud clicking sound is not heard, do not use. Replace winch immediately!
- Never release the crank handle unless the ratchet pawl is fully engaged, and the load is supported.
- Operate the winch by hand only. If the winch cannot be cranked using one hand, it is potentially overloaded.
- Periodically check winch mounting hardware for proper torque and tighten if necessary. Always replace bent, broken, or worn parts before using winch.
- Failure to follow proper procedures when mounting a tire on a wheel or rim can produce an explosion which may result in serious injury or death.
- Do not attempt to mount a tire unless you have the proper equipment and experience to do the job.
- Have a qualified tire dealer or repair service perform required tire maintenance.
- When replacing worn tires, make sure they meet the original tire specifications.

## 2.6.1 Hydraulic System Safety

- Make sure that all the components in the hydraulic system are kept clean and in good condition.
- Make sure all components are tight, and that lines, hoses and couplings are not damaged before applying pressure to the system.

- Do not use a hand to check for hydraulic oil leaks. Hydraulic fluid escaping under pressure can penetrate the skin causing serious injury. Use a piece of cardboard.



- Wear proper hand and eye protection when searching for a high-pressure hydraulic leak.

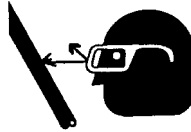

- Seek medical attention immediately if injured by a concentrated high-pressure stream of hydraulic fluid. Serious infection or toxic reaction can develop from hydraulic fluid piercing the skin surface.
- Do not attempt any makeshift repairs to the hydraulic lines, fittings or hoses by using tape, clamps, or cements. Doing so can cause sudden failure and create a hazardous and unsafe condition.
- Relieve pressure on the hydraulic system before working it. The hydraulic system operates under extremely high pressure.
- Replace any hydraulic hose immediately that shows signs of swelling, wear, leaks, or damage before it bursts.
- Check to make sure hydraulic hoses are not worn or damaged and are routed to avoid chafing.
- Never adjust a pressure relief valve or other pressure-limiting device to a higher pressure than specified.

## 2.8 Safety Sign Explanations

The top (or left-hand) panel shows the safety alert (the potential hazard), and the bottom (or right-hand) panel shows the message (how to avoid the hazard).

Practicing good safety means becoming familiar with safety signs and warnings and being aware of the situations that require alertness.

**Think SAFETY! Work SAFELY!**

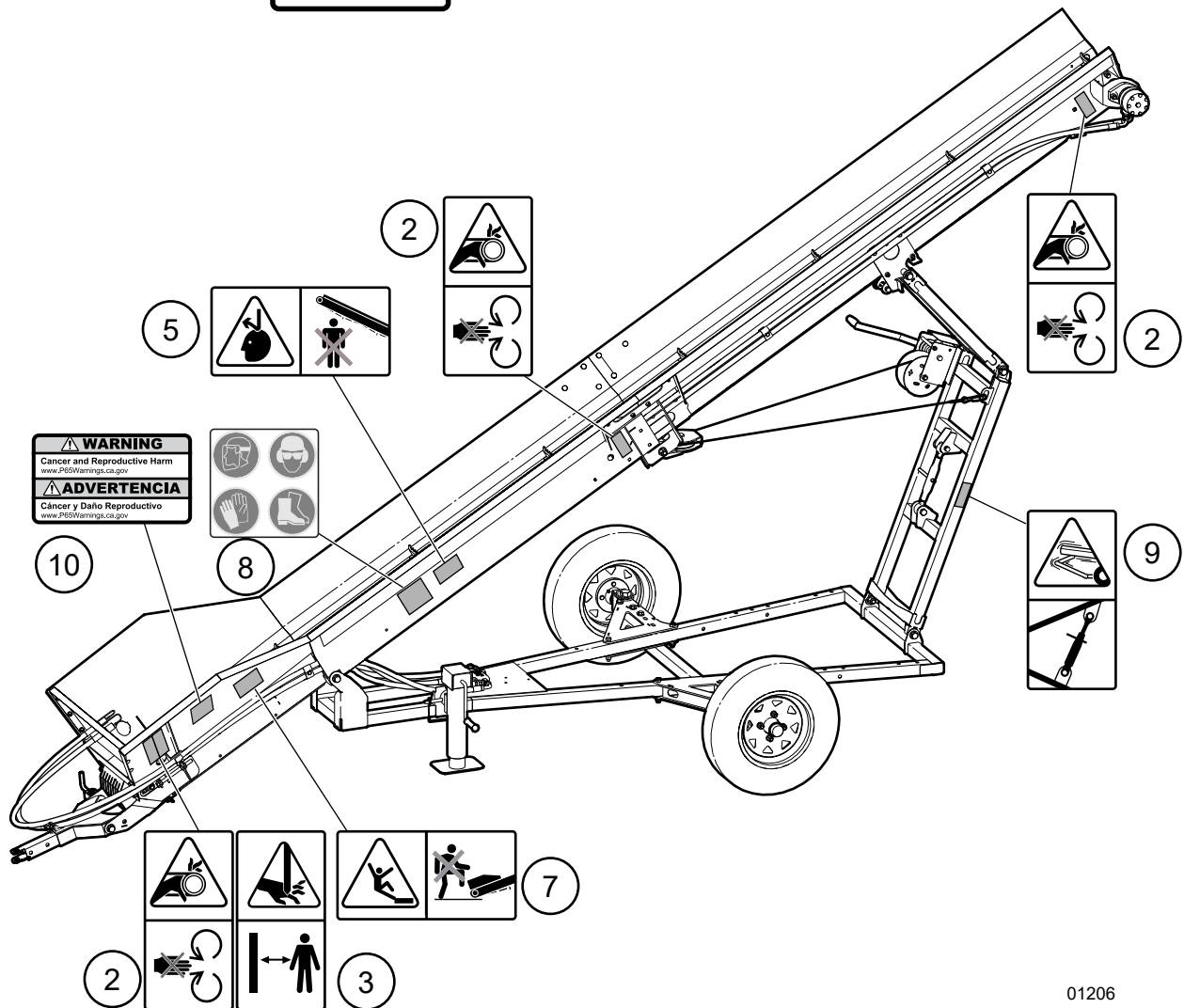
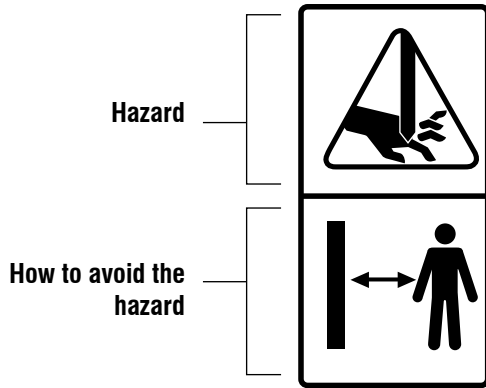

**WARNING**  
Cancer and Reproductive Harm  
[www.P65Warnings.ca.gov](http://www.P65Warnings.ca.gov)  
**ADVERTENCIA**  
Cáncer y Daño Reproductivo  
[www.P65Warnings.ca.gov](http://www.P65Warnings.ca.gov)



01206

Fig. 2—Conveyor Safety Decals

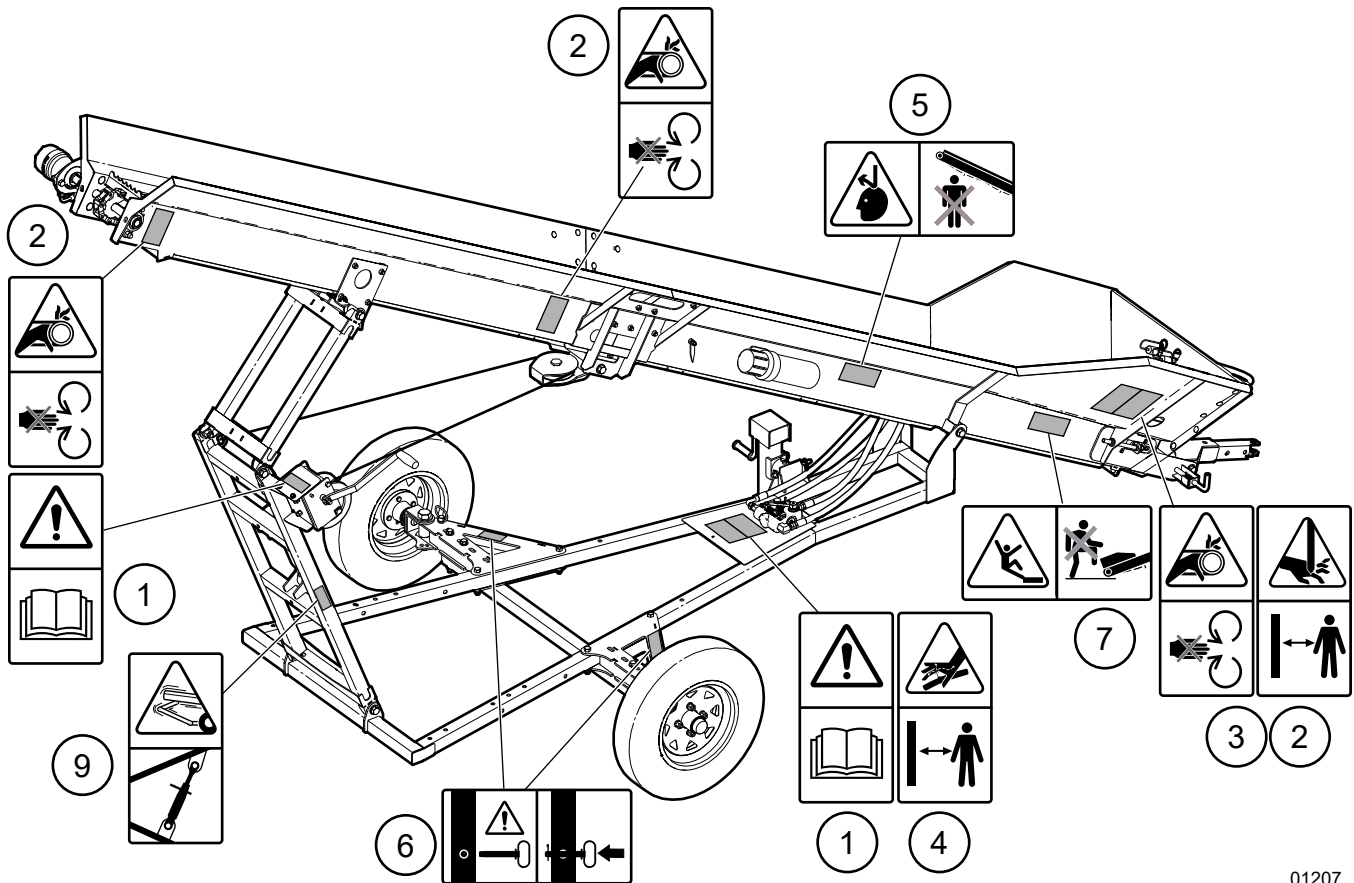

01207

Fig. 3—Conveyor Safety Decals

**1. Warning!**



Refer to the operator's manual. Understand ALL operating instructions in the manual and understand ALL safety signs located on the machine.

The most important safety device on this equipment is an informed operator.

**3. Warning!**



Risk of hands being crushed in this area.

Keep hands clear of all moving parts.

**2. Warning!**



Risk of hands being pinched or caught in drive chain resulting in serious injury.

Keeps hands clear of this area.

**4. Warning!**



Risk of hydraulic fluid escaping under high pressure and penetrating the skin causing serious injury.

Do not check for leaks with hand or fingers when the system is pressurized.

### 5. Warning!



**Risk of being injured from falling objects.**

Do not walk under the conveyor.

### 6. Warning!

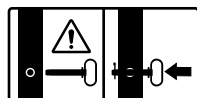

**Risk of machine moving unexpectedly when support pin is removed. Personal injury could result.**

Keep pin installed and secured with pin keeper.

### 7. Warning!



**Risk of being injured from falling off conveyor.**

Do not climb on the conveyor.

### 8. Safety Notice



**Always wear appropriate Personal Protective Equipment when using this machine.**

For example:

- A hard hat
- Heavy gloves
- Hearing protection
- Protective shoes with slip resistant soles
- Protective glasses, goggles, or face shield

### 9. Caution!



**Risk of conveyor frame moving or bouncing unexpectedly during operation or when transporting. Personal injury could result.**

Install topline to lock top and bottom folding frames together.

### 10. Warning!



**Risk of cancer or reproductive harm.**

The machine materials contain chemicals or machine operation may produce gases or dust that are identified by the state of California as causes of cancer, birth defects, or other reproductive harm.

This warning is required by the state of California, USA to comply with Proposition 65: the Safe Drinking Water and Toxic Enforcement Act of 1986.

**IMPORTANT! If parts are replaced that have safety signs on them, new signs must be applied. Safety signs must always be replaced if they become damaged, are removed, or become illegible.**

Safety signs are included in the product decal kit available from your authorized dealer. Decals are not available separately.

## 2.9 Replacing Damaged Safety Signs

Replace any safety sign that is damaged or missing. If a safety sign is attached to a part that is replaced, install a safety sign on the replacement part. Replacement safety signs are available from your authorized distributor, dealer parts department, or Wallenstein Equipment.

### Procedure

Installation area must be clean and dry. Make sure the surface is free of grease or oil. Ambient temperature must be above 50 °F (10 °C).



*Determine exact position before removing the backing paper on the decal.*

1. Peel the decal off the backing sheet.
2. Align the decal with an edge on the machine if possible.
3. Starting on one edge, carefully press the center of the exposed sticky backing in place, smoothing it out as you work from one side to the other.
4. Use a squeegee, credit card or similar to smooth it out. Work from one end of the decal to the other end.

Small air pockets can be pierced with a pin and smoothed out using the piece of sign backing paper.

## 2.10 Sign-Off Form

Wallenstein Equipment Inc. follows the general safety standards specified by the International Organization for Standardization (ISO).

Anyone who is going to use or service this conveyor must read and clearly understand ALL Safety, Usage and Maintenance information presented in this manual. Do not use or allow anyone else to use this machine until such information has been reviewed. Review this information annually before the season start-up.

Make these periodic reviews of safety and operation a standard practice for all equipment. An untrained operator is unqualified to use this machine.

A sign-off sheet is provided for your record keeping. Use it to record personnel who will be working with the equipment have read and understand the information in the Operator's Manual and have been instructed in the operation of the equipment.

Sign-off Form		
Date	Owner	Employee

Safety

## 3. Familiarization

---

**IMPORTANT!** Before starting work with the conveyor, become familiar with the location and function of all controls.

---

### 3.1 To the New Operator

It is the responsibility of the owner or operator to read this manual and to train all other operators before they start working with the machine. Follow all safety instructions exactly.

By following recommended procedures, a safe working environment is provided for the operator, bystanders, and the area around the work site. Untrained operators are not qualified to use the machine.

### 3.2 Training

Each operator must be trained in the proper set-up and operating procedures prior to being allowed to operate the machine.

### 3.3 Job Site Familiarization

It is the responsibility of the operator to be thoroughly familiar with the work site prior to starting. Doing so can prevent the chance of problems or accidents.

### 3.4 Equipment Condition

1. Check the general condition of the conveyor. Ensure that all nuts and bolts are secure and that moveable parts are secured and in their proper place.
2. Always inspect the wire rope as it is pulled out of the winch. Do not use the machine if the rope is cut, frayed, worn or knotted. Any problem can result in early failure and create an unsafe operating condition. Replace damaged wire rope before resuming work.

### 3.5 Operator Orientation

---

**IMPORTANT!** The directions mentioned throughout this manual for left-hand, right-hand, backward, and forward are determined when facing the direction of forward travel.

---

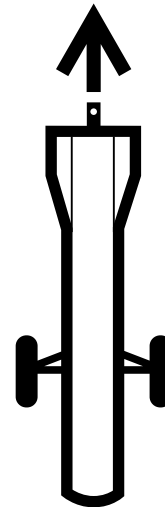

### 3.6 Conveyor Components

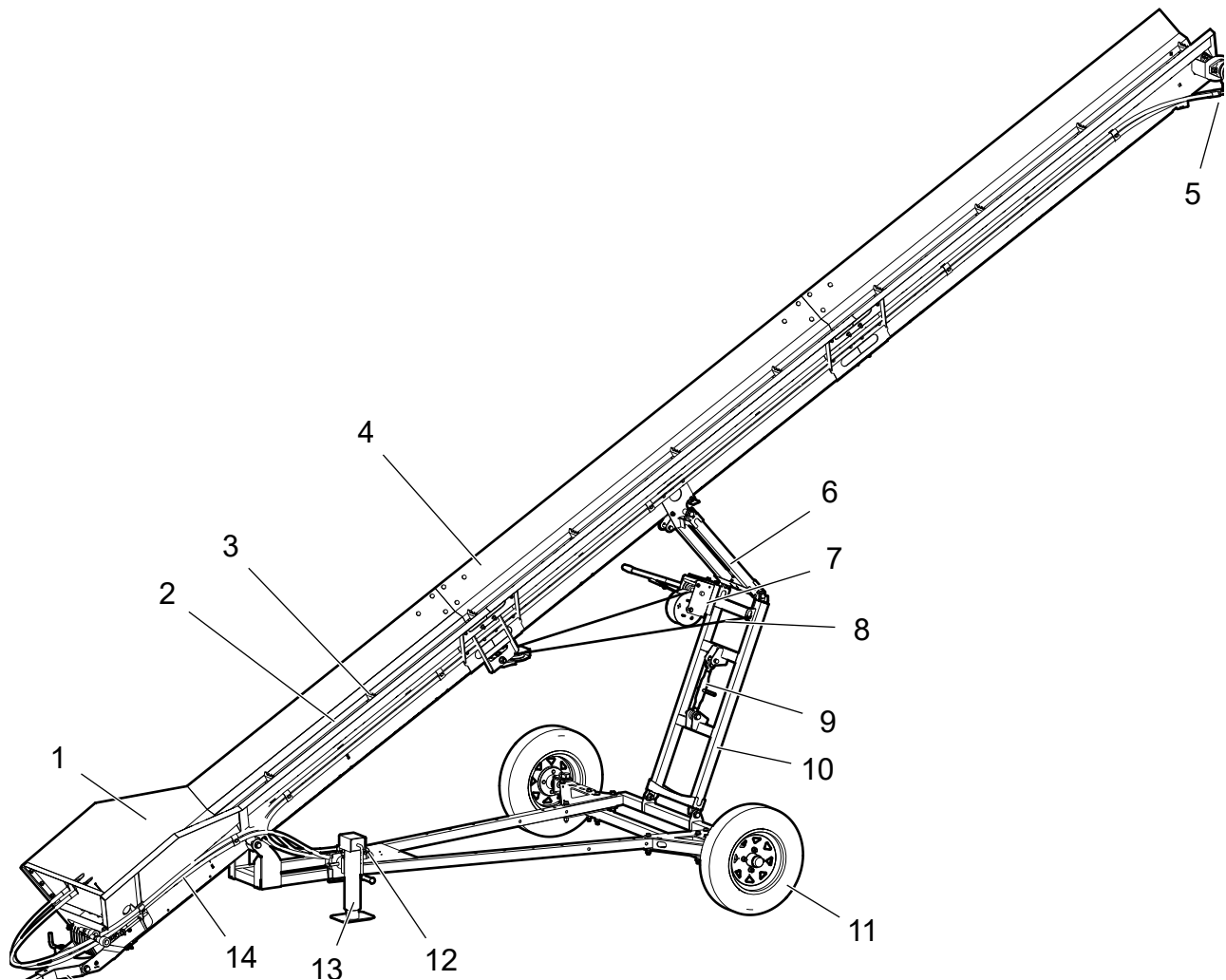

**Fig. 4–**CT24 Conveyor Components

- |                    |                          |                        |
|--------------------|--------------------------|------------------------|
| 1. Conveyor Hopper | 6. Folding Frame, Upper  | 11. Wheels             |
| 2. Conveyor Chain  | 7. Hand Winch            | 12. Flow Control valve |
| 3. Chain Cleats    | 8. Winch Cable           | 13. Crank Jack         |
| 4. Conveyor Trough | 9. Toplink               | 14. Hydraulic Hoses    |
| 5. Hydraulic Motor | 10. Folding Frame, Lower | 15. Hitch              |



## 4. Conveyor Setup

### **! CAUTION!**

**Park conveyor where wheels are on firm, level ground. Never raise or move conveyor if wheels are on uneven ground.**

1. Position the conveyor so that split wood from the processor discharge falls into the conveyor hopper.
2. Block the wheels so conveyor cannot roll in either direction.
3. Unlock the conveyor hitch. Pull out the Hitch Lock Pin and turn to unlock.

**IMPORTANT! Failure to unlock hitch can cause damage as the conveyor is raised.**

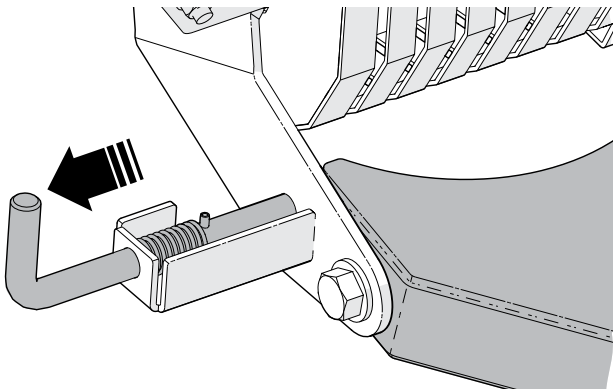

Fig. 5—Hitch Lock Pin

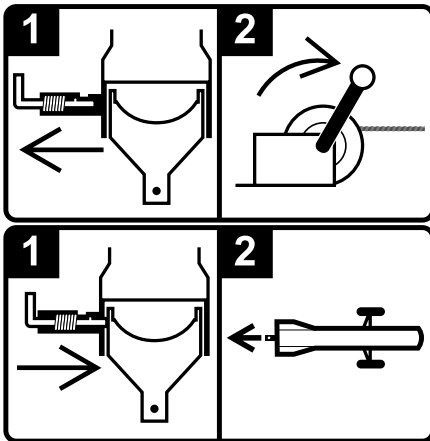
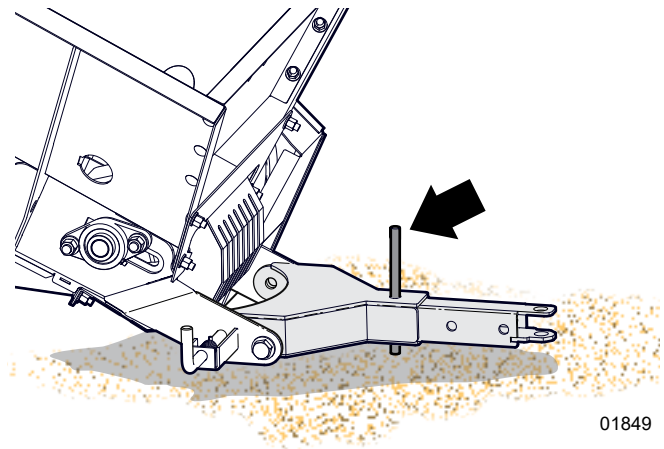

Fig. 6—Decal on hitch plate

4. Anchor the conveyor under the processor discharge by driving a 1/2" (12 mm) steel rod (not supplied) through the hole in the hitch into the ground. Anchoring it also holds the hopper in place if repositioning the conveyor.



01849

Fig. 7—Steel Rod through Conveyor Hitch

5. Disconnect the Toplink Pin (if connected) and place it in the stored position.

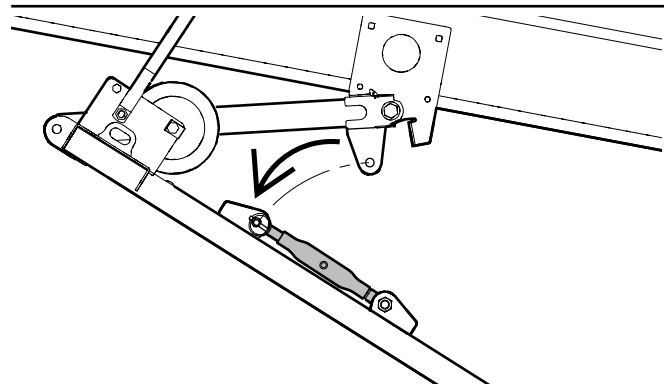
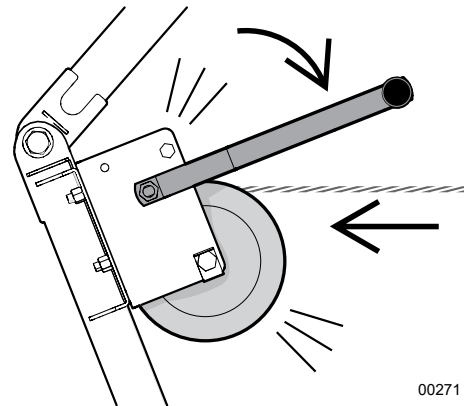

Fig. 8—Toplink Pin

6. Set the conveyor height as required. Turn winch handle clockwise to raise it. Counterclockwise lowers it.



00271

Fig. 9—Conveyor Winch Handle

---

**7. Connect Hydraulic Lines.**

- The conveyor requires an external hydraulic power source of minimum 3 US gpm (11.3 Lpm) at 3000 psi (207 bar).
  - Conveyor pressure and return hoses have 1/2" quick-disconnect fittings with protective caps. The red cap is the pressure line and black is return to tank.
- 

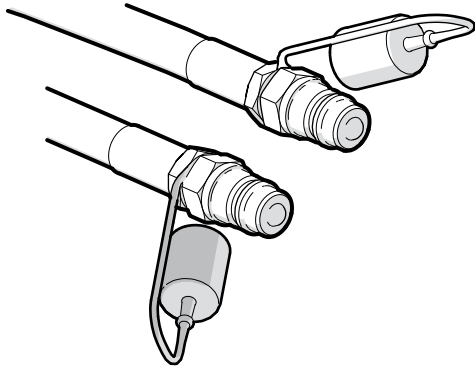

00480

---

**Fig. 10**—Hose Connections

- If connecting the conveyor to the Wallenstein WP1624 wood processor, an auxiliary valve kit is required to control the conveyor. Refer to the parts manual for information on the optional valve kit.
- **If the conveyor is equipped with the Accessory Hydraulic Power Pack, see *page 24* for operating instructions.**

## 5. Operating Instructions

### 5.1 Break-in Period

Although there are no operational restrictions on the conveyor when used for the first time, it is recommended that the following items be checked:

#### After 1–5 hours of operation:

1. Check all nuts, bolts, and other fasteners. Tighten to their specified torque. See general bolt torque table *page 41*.
2. Check for entangled material. Remove all entangled material before resuming work.

#### After 50 hours of operation

3. Adjust conveyor chain tension. See *page 35*.
4. Check condition of hand winch and wire rope. Replace wire rope if kinked, worn, or has broken strands.

### 5.2 Pre-Operation Checklist

Before using the conveyor, review this checklist.

Pre-operation Checklist	✓
Make sure conveyor chain is clear for startup. Check for entangled material.	
Park conveyor on stable, level ground. Block or chock wheels so it cannot roll in either direction.	
Check conveyor bearings are greased as per the schedule outlined in the Maintenance Section.	
Make sure that all covers, guards and shields are in place, secured and functioning as designed.	
Check all fasteners and tighten as required. Make sure equipment is working as designed and in good repair.	
If conveyor is off-loading into a truck or trailer, plan access for this equipment.	
Check that personal protection equipment including hard hat, safety glasses, safety shoes, safety vest, hearing protection and gloves are being used and in good repair.	
Check that all loose-fitting clothing or jewelry is not worn, and loose, long hair is tied back.	

### 5.3 Conveyor Height, Adjusting

Change the conveyor angle using the hand winch. There are stops provided on the conveyor frame; however, do not raise the conveyor higher than the safe zone on the conveyor angle indicator. See *page 20*.

#### ⚠ WARNING!

Do not use the hand winch if the wire rope (cable) is worn, kinked or frayed. It could break collapsing the conveyor and whip violently causing serious injury or death. Replace wire rope if damage is apparent.

W046

#### To Raise the Conveyor Angle

#### ⚠ CAUTION!

Conveyor wheels must always be parked on firm, level area. Never raise conveyor if wheels are positioned on uneven ground.

- Turn winch handle clockwise. A loud clicking sound is heard while raising.

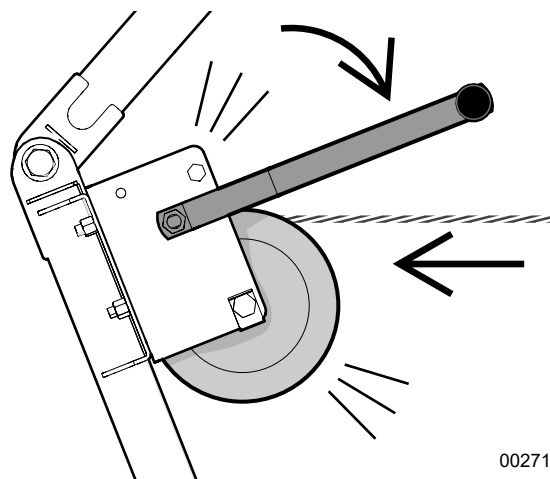

00271

Fig. 11 – Raise Conveyor

**IMPORTANT!** Winch requires 45 lb (200 N) of handle force. Excessive force in turning winch handle may indicate overload.

## To Lower the Conveyor Angle

- Turn the winch handle counterclockwise. No clicking sound is heard because the brake system is activated.

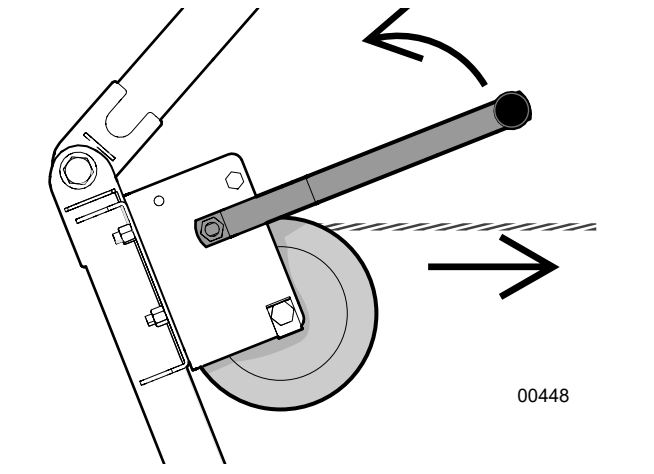

Fig. 12—Lowering Conveyor

## 5.4 Setting Conveyor Speed

The conveyor is powered by an external hydraulic source, unless equipped with the accessory hydraulic power pack. The pressure and return lines are connected to the flow control valve on the conveyor frame.

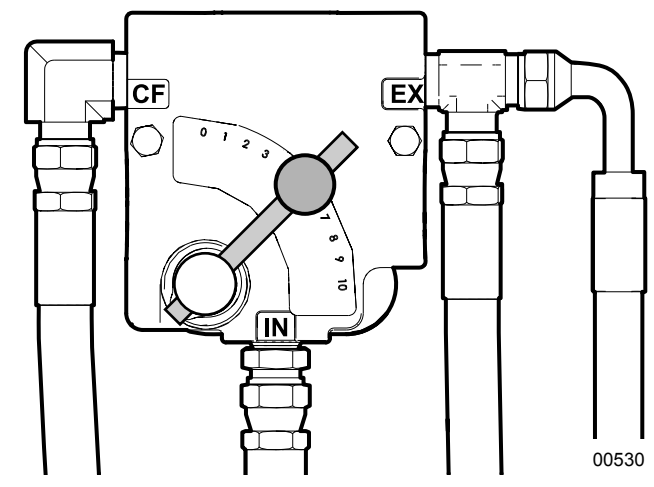

Fig. 13—Flow Control Valve

1. **IN** – Oil Supply from Power Source
2. **CF** – Controlled Flow to Conveyor Motor
3. **EX** – Excess Flow to Tank Return

The valve controls oil flow supplied to the conveyor hydraulic motor. Once set, it maintains constant conveyor speed regardless of load variation.

Pressurized oil is supplied to the **IN** port on the valve. Flow is regulated with the valve lever so controlled oil flow exits through the **CF** port to power the conveyor motor. Excess flow not required, is diverted to the **EX** port and returns to tank. Return from the conveyor motor is connected at the **EX** port.

**With the conveyor operating, adjust flow control valve to preferred off-load speed.**

1. Loosen the knob and move the valve handle to desired speed.
2. Re-tighten the knob to lock handle at the set speed.

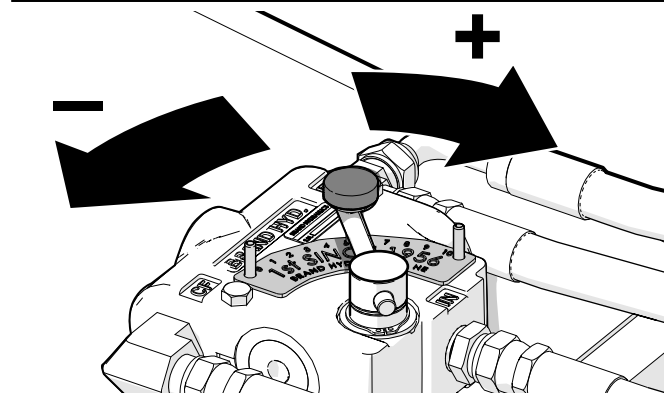

Fig. 14—Flow Control Valve Operation

## 5.5 Conveyor Angle Indicator

Some site conditions may require parking the conveyor on ground that slopes up or down.

As a guide for a safe conveyor operating inclination, use the indicator on the right-hand side of the conveyor

When raising, always keep the indicator in white zone on the decal.

- White indicates a normal, safe operating angle (0°–35°).
- Yellow indicates the conveyor is approaching an unsafe angle (35°–45°). Use caution.
- Red is an unsafe angle (45°–55°). Lower the conveyor immediately.

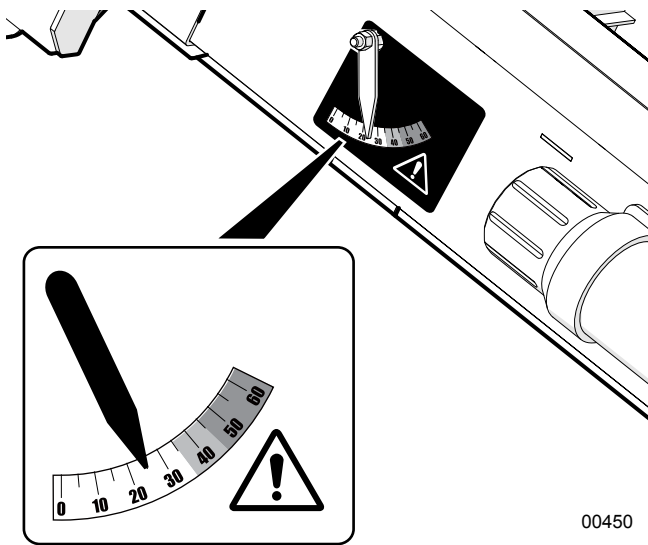

Fig. 15 – Conveyor Angle Indicator

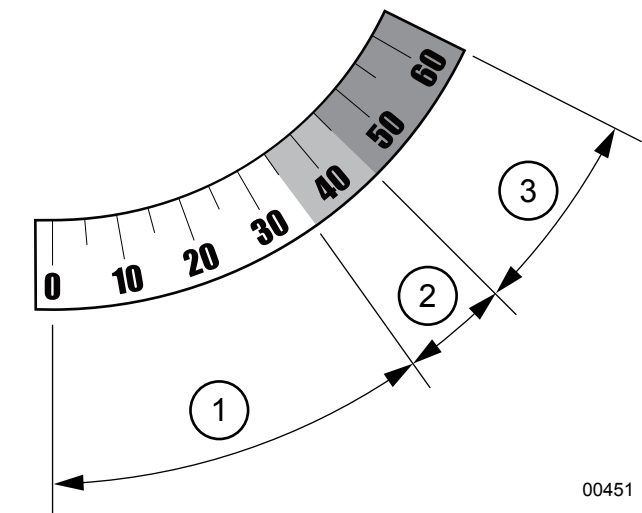
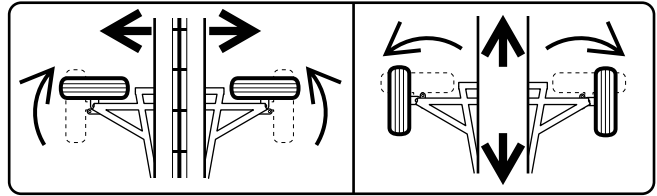

Fig. 16 – Indicator Zones

1. Safe Working Angle (white)
2. Approaching Unsafe Angle (yellow)
3. Unsafe Angle (red)

## 5.6 Rotating Wheels

Move the conveyor sideways when the split wood stack height is up to the conveyor or approaching the wheels. Unpin and rotate the wheels to swing the conveyor.



- Remove lynch pin, then pull the pin and rotate the wheel. Reinsert pin and lynch pin.
- Push the conveyor to the new position.
- Chock or block the wheels.

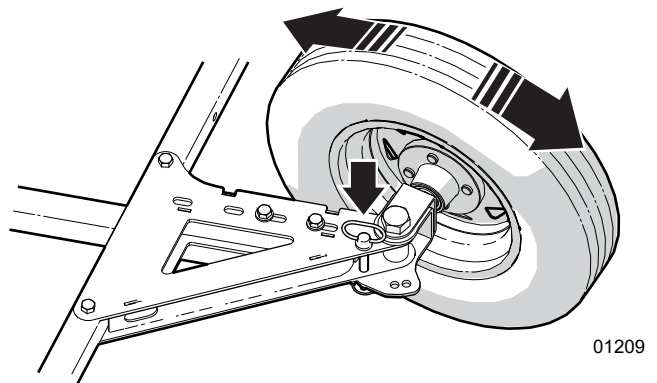
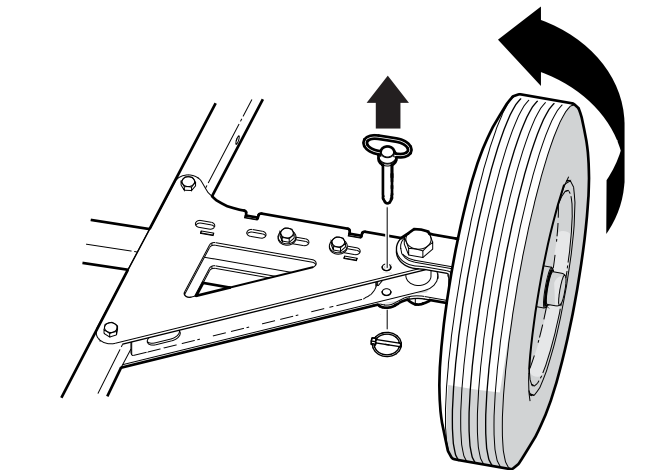
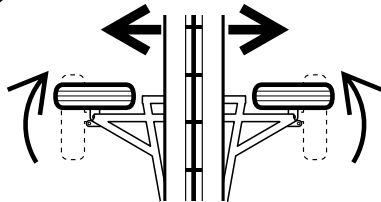

Fig. 17 – Rotating the Conveyor Wheels

## 5.7 Moving, Swinging the Conveyor Sideways

- Unload the conveyor. Allow it to operate until all the split wood has cleared. If equipped with the power pack option, shut the engine down. Shut down the wood processor.
- Lower the conveyor down to the stops on the frame.
- Remove the blocks and rotate the wheels. See *page 31* for instructions on wheel rotation.



- Push the conveyor to the new position.
- Block the wheels.
- Check the position of the hopper end of the conveyor. Make sure it is placed so split wood falls properly from the processor discharge chute.
- Reposition conveyor hopper if required, then drive a 1/2" (12 mm) steel rod (not supplied) through the hitch into the ground to anchor it there.

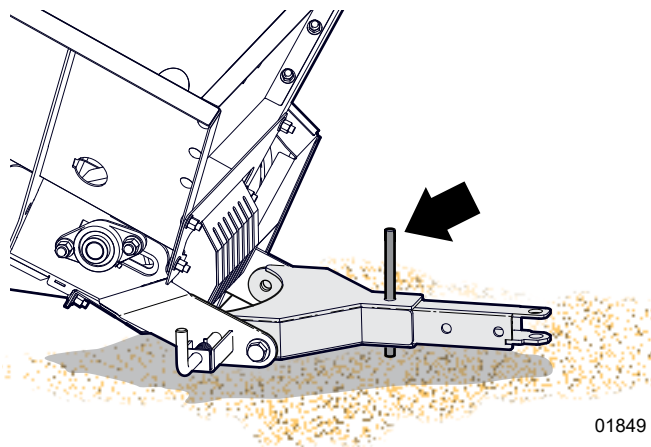

01849

**Fig. 18**–Steel Rod through Conveyor Hitch

## 5.8 Conveyor Axle Position

Axle position on the wheel base frame is based on whether the conveyor is equipped with a power pack. Tongue weight varies depending on conveyor length and installed accessories.

The standard CT conveyor comes with pressure and return hoses for the hydraulic motor to drive the conveyor chain. It requires an external power source, typically provided by the wood processor. If the accessory power pack is installed on the conveyor, the axles are repositioned to lower weight on the tongue.

### Axle Location on Wheel Base Frame

The axle is positioned and bolted to the conveyor frame based on the measurements in the following table. Measure from the front of the wheel base frame to the center of the axle (measurement 'X').

Measurement 'X'	
No Power Pack <sup>1</sup>	Power Pack Equipped <sup>2</sup>
6" (15.2 cm)	9" (23 cm)

- 1 Standard configuration  
2 Accessory power pack mounted on frame

## Tongue Weight, Adjusting

Tongue weight can be further adjusted for towing vehicle capability or preference using the additional holes provided in the conveyor wheel base frame.

**IMPORTANT! If repositioning axles, always make sure spanner bar is installed and all fasteners are properly torque-tightened.**

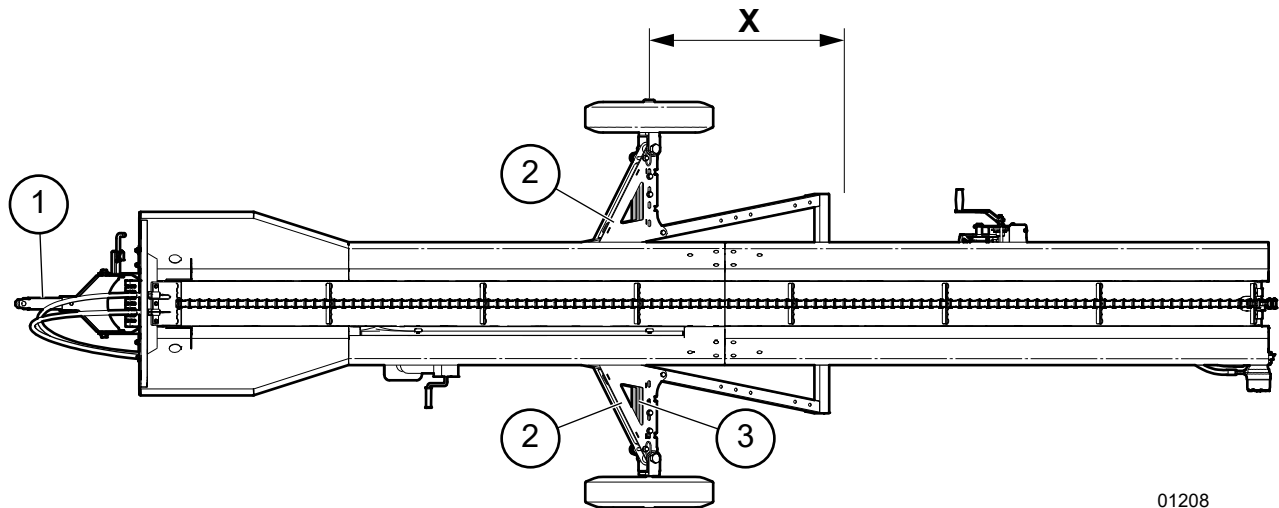

01208

Fig. 19 – Axle Position on Wheel Base Frame

1. Conveyor Tongue  
2. Axles  
3. Spanner Bar

## 5.9 Accessory Hydraulic Power Pack

The accessory Hydraulic Power Pack is required when there is no external hydraulic power source available for the Wallenstein conveyor. It mounts directly onto the conveyor frame and connects to the flow control valve.

The kit is self-contained, powered by a Honda® GX200 engine coupled to a pump, with an oil reservoir, hoses, return filter, and control valve.

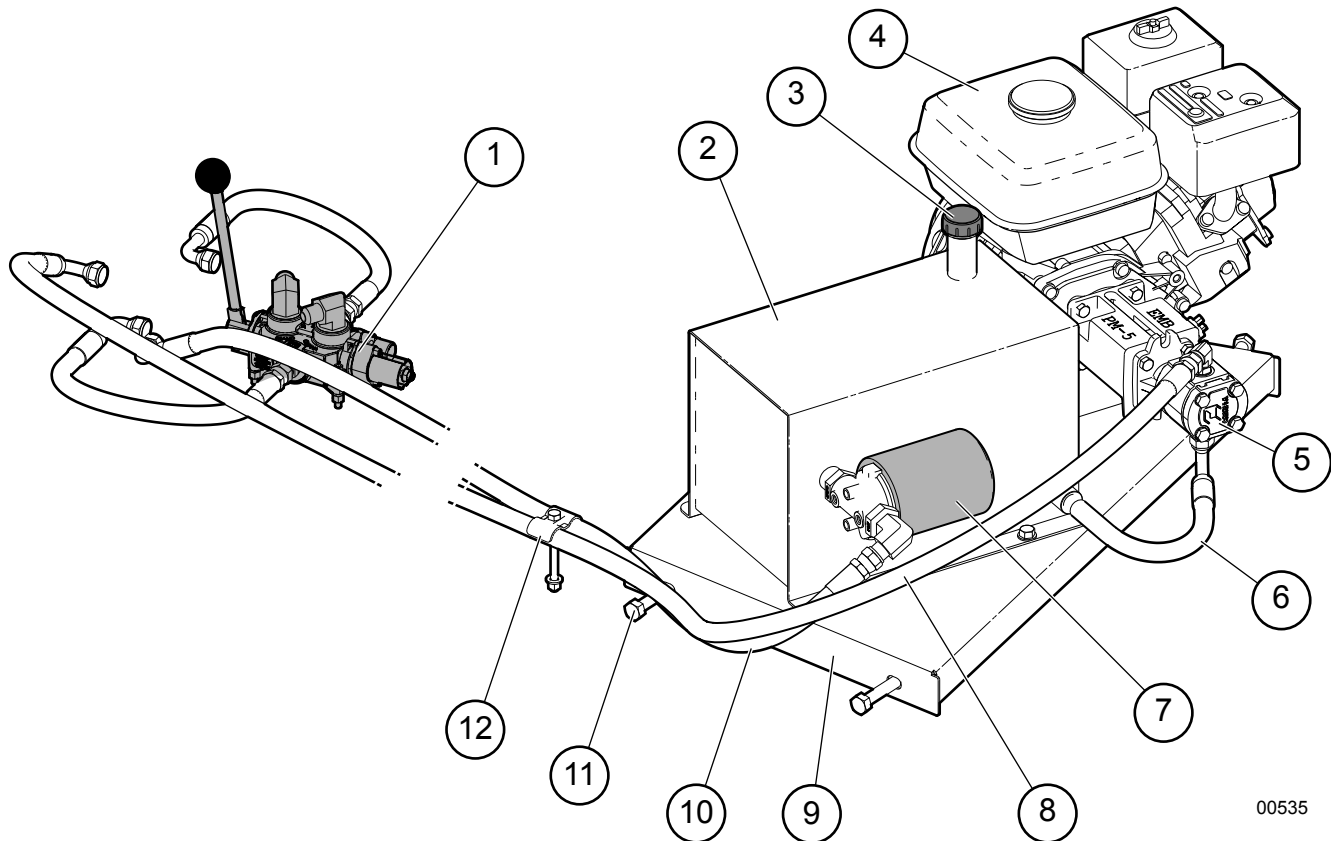

00535

**Fig. 41**—Accessory Hydraulic Power Pack

- |                                     |                   |                              |
|-------------------------------------|-------------------|------------------------------|
| 1. Control Valve                    | 5. Hydraulic Pump | 9. Base                      |
| 2. Hydraulic Tank                   | 6. Suction Line   | 10. Return Line              |
| 3. Oil Level Dipstick / Filler Tube | 7. Return Filter  | 11. Mounting Bolts           |
| 4. Honda® GX200 Engine              | 8. Pressure Line  | 12. Hose Clamps and Hardware |



## 5.9.1 Engine Controls

Refer to the engine manual that came with this product for further explanation on engine controls.

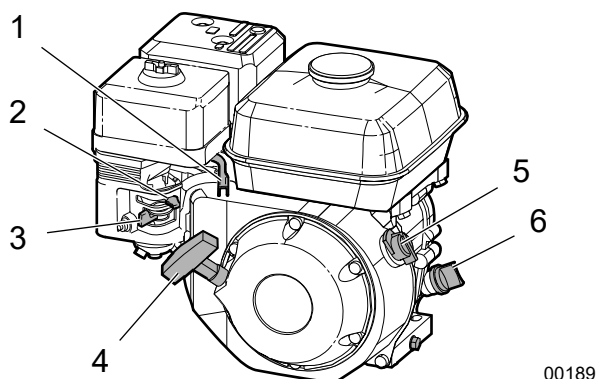

Fig. 20—Engine Controls

1. Throttle Lever
2. Choke Lever
3. Fuel Valve Lever
4. Recoil Starter Rope
5. Ignition Switch

### Throttle Lever

This lever controls engine speed. Move the lever side to side to increase or decrease engine rpm. Always operate the engine with the throttle lever in the MAX position.

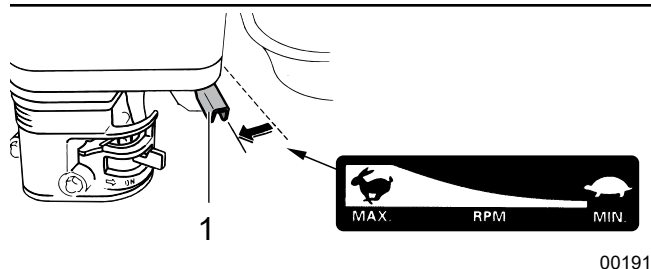

Fig. 21—Throttle Lever Positions

1. Throttle Lever

### Choke Lever

The choke lever opens and closes the choke valve in the carburetor.

- Place the choke lever in the CLOSED position (3) when starting a cold engine.
- Move the choke lever to the OPEN position (2) after the engine starts. When restarting a warm engine, leave the lever in the OPEN position.

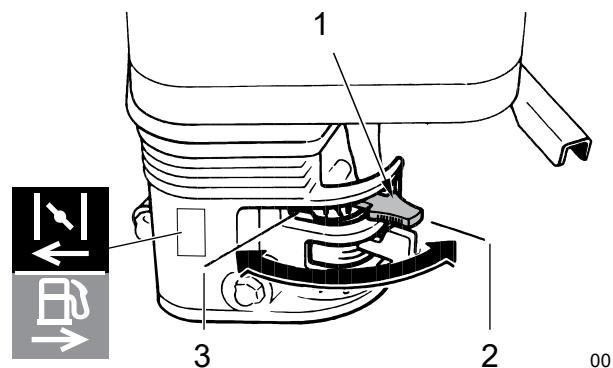

Fig. 22—Choke Lever

1. Choke Lever
2. Choke Open Position
3. Choke Closed Position

### Fuel Shut-off Valve

The engine is equipped with a valve between the fuel tank and the carburetor.

- Slide the fuel valve lever toward the engine block (2) to turn fuel ON, and away (3) to turn OFF.
- Turn the fuel OFF when not in use or when transporting.

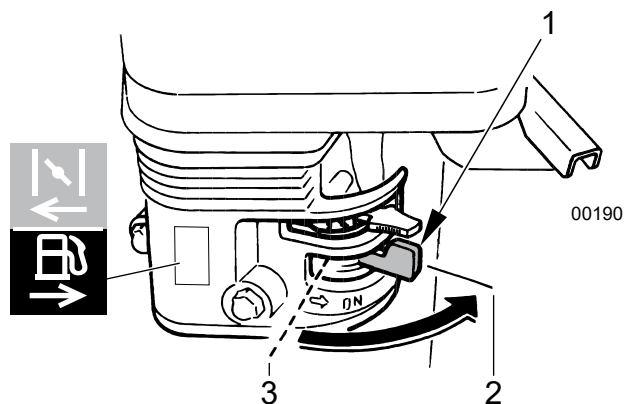
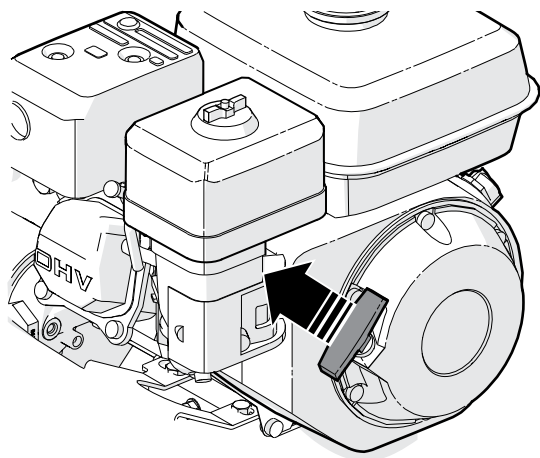

Fig. 23—Fuel Valve Lever

1. Fuel Shut-off Valve Lever
2. ON Position
3. OFF Position

## Recoil Starter Rope

Pull the starter grip out lightly until resistance is felt, then pull briskly in the direction of the arrow as shown below. Return the starter grip gently.



00447

Fig. 24—Recoil Starter

## 1. Ignition Switch

This rotary switch controls the ignition system.

- The engine operates in the ON position. Before starting the engine, turn the switch to ON.
- Turn it counterclockwise to OFF to stop the engine.

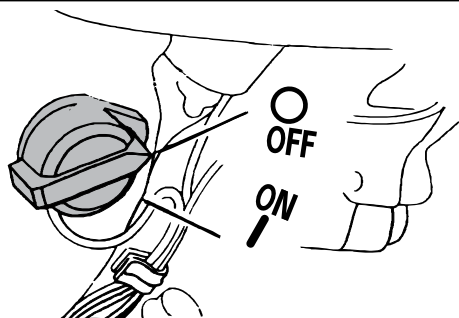

00187

Fig. 25—Ignition Switch

## 5.9.2 Control Valve Operation

The control valve starts and stops the conveyor and is connected to the flow control valve. Conveyor speed is controlled by flow control valve.

- Pull the lever back to start the conveyor drive. A detent holds the lever in drive until moved. Adjust speed with the flow control valve.
- Stop the conveyor drive by pushing the lever forward.

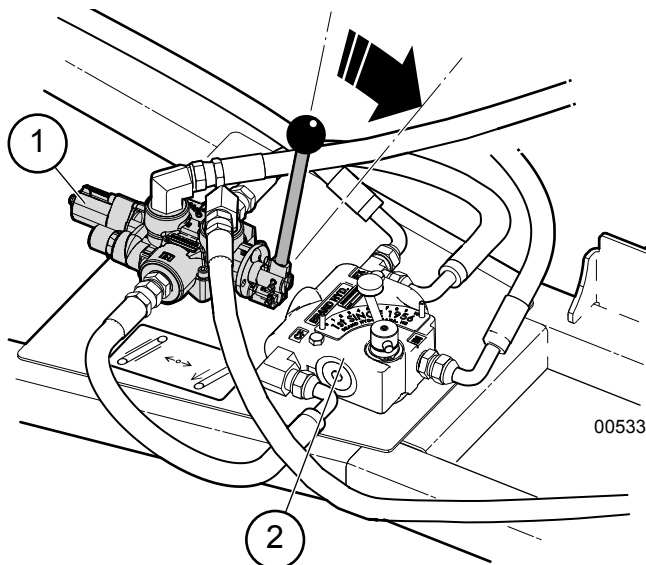

00533

Fig. 26—Conveyor Control Valve

1. Conveyor Control Valve (On/Off)
2. Flow Control Valve (Speed)

### 5.9.3 Engine Operating Instructions

#### CAUTION!

Before starting the engine, review the safety, operating, and maintenance instructions in the engine manual.

W019

#### CAUTION!



Hearing loss hazard. Prolonged exposure to loud noise may cause permanent hearing loss. Use suitable protection while operating the machine.

W016

#### WARNING!

Engine exhaust contains carbon monoxide, an odorless, poisonous gas. Breathing it can cause unconsciousness or death.

Never operate engine in a closed, or even partly closed area. Exhaust gases can build up to dangerous levels.

W072

- **DO NOT** operate engine with an accumulation of grass, leaves, dirt, or other combustible materials in the muffler area.
- **DO NOT** use this engine on any forest covered, brush covered, or grass covered unimproved land unless a spark arrester is installed on the muffler. The arrester must be maintained in effective working order by the operator. In the state of California, the above is required by law (Section 4442 of the California Public Resources Code). Other states may have similar laws. Federal laws apply on federal land.
- **DO NOT** touch hot muffler, engine body or cooling fins. Contact may cause burns.
- **DO NOT** run engine with air cleaner or air cleaner cover removed.

#### Be sure to:

- Remove the wire from the spark plug when servicing the engine or equipment to prevent accidental starting. Disconnect the (-) ground wire from the battery terminal.
- Keep engine cooling fins and governor parts free of grass and other debris that can affect engine speed.
- Use fresh gasoline. Old fuel can clog carburetor and cause leakage.
- Check fuel lines and fittings frequently for cracks or leaks. Replace if necessary.

### Engine Safety

- **DO NOT** operate engine in an enclosed area. Exhaust gases contain odorless and deadly carbon monoxide that can cause death by asphyxiation.
- **DO NOT** place hands or feet near moving or rotating parts.
- **DO NOT** store, spill, or use gasoline near an open flame, or devices such as a stove, furnace, or water heater which use a pilot light or devices which can create a spark.
- **DO NOT** choke carburetor to stop engine. Whenever possible, gradually reduce engine speed before stopping.
- **DO NOT** run engine above rated speeds. This may result in injury.
- **DO NOT** tamper with governor springs, governor links or other parts which may increase the governed speed.
- **DO NOT** tamper with the engine as set by the original equipment manufacturer.
- **DO NOT** check for spark with spark plug or spark plug wire removed.
- **DO NOT** crank engine with spark plug removed. If engine is flooded, crank until engine starts.
- **DO NOT** operate engine without a muffler. Inspect periodically and replace if necessary.

## 5.9.4 Engine Oil Level Check

Check engine oil level daily.

Check with the machine parked on level ground and the engine stopped.

**IMPORTANT! Running the engine with a low oil level can cause engine damage that is not covered by warranty.**

1. Remove the oil level dipstick and wipe it clean.
2. Fully insert the oil level dipstick, then remove it to check the oil level. **The proper level is when the oil is visible at the full (upper) mark on the dipstick.**
3. If the oil level is low, add oil until the level is at the full mark. **SAE 10W-30 is recommended for general use.**
4. Reinstall the oil level dipstick.

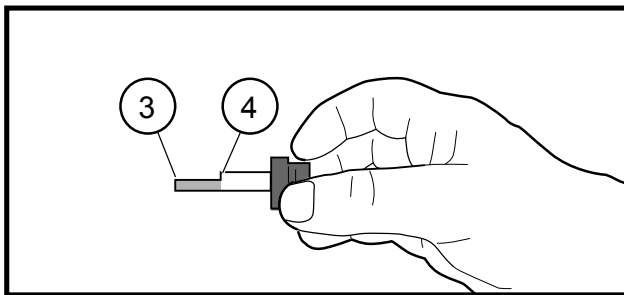
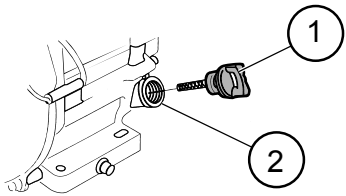

00454

Fig. 27—Engine Oil Level check

1. Oil Level Dipstick
2. Oil Filler
3. Low Oil Level
4. Full Mark

## 5.9.5 Fuel Level Check

Check the fuel level daily.

Starting with a full tank helps to eliminate or reduce operating interruptions for refueling.

The fuel tank is located on the engine. Avoid running the tank dry.

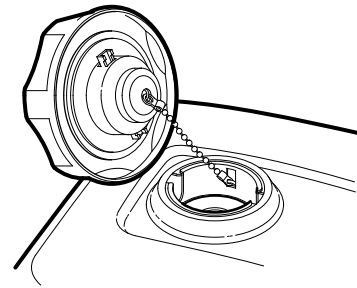

00198

Fig. 28—Fuel Filler Cap

## Refueling

Fuel tank capacity: **0.95 US gal (3.6 L)**

**! WARNING!**



Fuel vapors can explode causing injury or death. Do not smoke while refueling. Keep sparks, flames, and hot components away.

W027

- **DO NOT** refuel indoors where area is not well ventilated.
- **DO NOT** refuel while engine is running. Allow engine to cool for five minutes before refueling. Store fuel in approved safety containers.
- **DO NOT** remove fuel tank cap while engine is running.
- **DO NOT** operate engine if gasoline is spilled. Move machine away from the spill and avoid engine ignition until gasoline has evaporated.
- **DO NOT** smoke while filling fuel tank.
- Prevent fires by keeping machine clean of accumulated trash, grease, and debris.

For fuel specification, see *Fluids and Lubricants on page 34* . Refer to the engine manual for additional information on fuels.

1. Clean the area around fuel tank cap. Fill the tank to 1/2" (12 mm) below bottom of filler neck to provide space for any fuel expansion. Do not overfill.
2. Install fuel fill cap securely and wipe up any spilled fuel.

## Engine Air Cleaner

A dirty air filter can restrict air flow to the carburetor, reducing engine performance. If the engine is operated in very dusty areas, clean the air filter more often than specified.

**IMPORTANT! Operating the engine without an air filter, or with a damaged air filter, can allow dirt to enter the engine, causing rapid engine wear. This type of damage is not covered by Warranty.**

## Inspection

- Remove the air cleaner cover.
- Remove the foam filter element from the paper filter element.
- Clean or replace dirty filter elements. Always replace damaged filter elements.

 **NOTE:** Refer to the engine manual for further information on servicing the air cleaner.

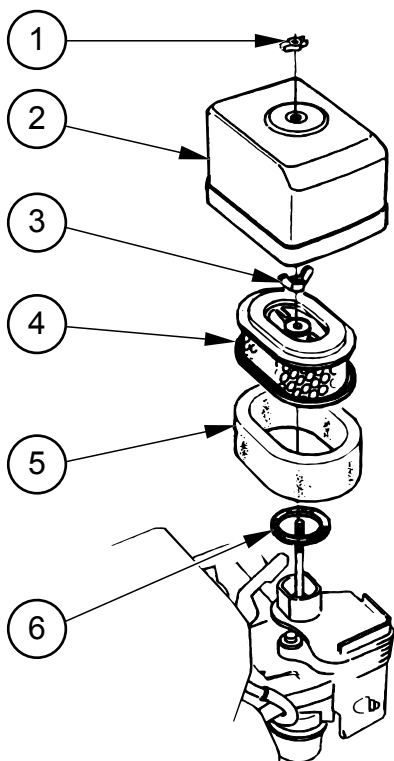

00455

**Fig. 29**—Engine Air Cleaner

1. Wing Nut
2. Air Cleaner Cover
3. Wing Nut
4. Paper Filter Element
5. Foam Filter Element
6. Gasket

## Hydraulic Oil Level Check

Check hydraulic oil level daily with the engine stopped.

Pull out the dipstick to check the oil level. **The correct level is when the oil is at the upper mark on the dipstick.** Add oil as required.

**IMPORTANT!** Do not operate machine if oil level is low. Damage to the pump and other components can occur.

**IMPORTANT!** Hydraulic oil quality should be inspected every 50 hours. If the oil is dirty or smells burnt, it should be replaced.

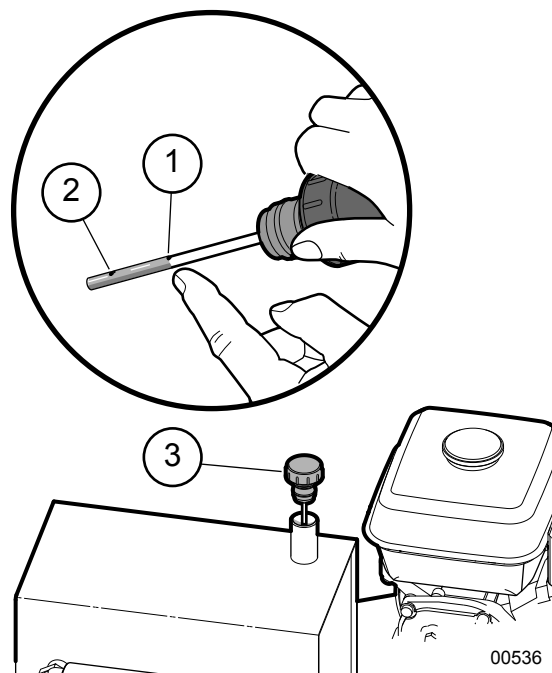

**Fig. 30**—Hydraulic Oil Level Check

1. High Oil Level Indicator Mark
2. Low Oil Level Mark
3. Oil level Dipstick in Reservoir

## Adding Oil to the Tank

The hydraulic system uses **Dexron® III ATF**.

3. Clean the area around filler cap and remove it.
4. Use a clean funnel to add oil. Check the level by inserting the dipstick then removing it to examine.
5. Install filler cap securely afterward. Wipe up any spilled oil.

Check levels after changing filters or servicing hydraulic components.

### 5.9.6 Starting the Engine

#### **CAUTION!**

Before starting the engine, review the safety, operating, and maintenance instructions in the engine manual.

W010

#### **WARNING!**

Engine exhaust contains carbon monoxide, an odorless, poisonous gas. Breathing it can cause unconsciousness or death.

Never operate engine in a closed, or even partly closed area. Exhaust gases can build up to dangerous levels.

W072

#### **CAUTION!**



Hearing loss hazard. Prolonged exposure to loud noise may cause permanent hearing loss. Use suitable protection while operating the machine.

W016

Make sure the conveyor is set up to work and otherwise ready to run.

1. Slide the fuel valve lever toward the block (2) to turn fuel ON.

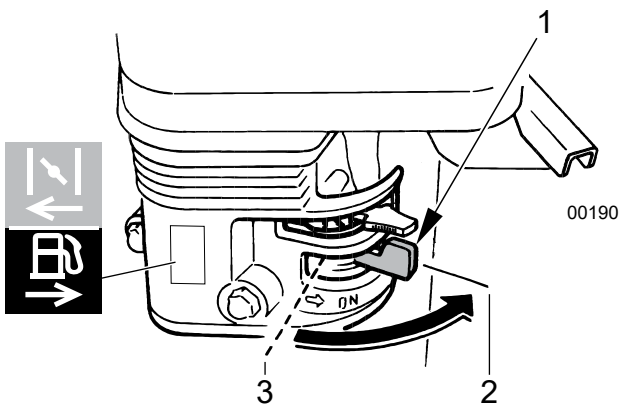

00190

**Fig. 31 – Fuel Valve Lever**

1. Fuel Shut-off Valve Lever
2. ON Position
3. OFF Position

2. If the engine is cold, close the choke (push choke lever to the left). To start a warm engine, leave the choke open (lever pushed to the right).

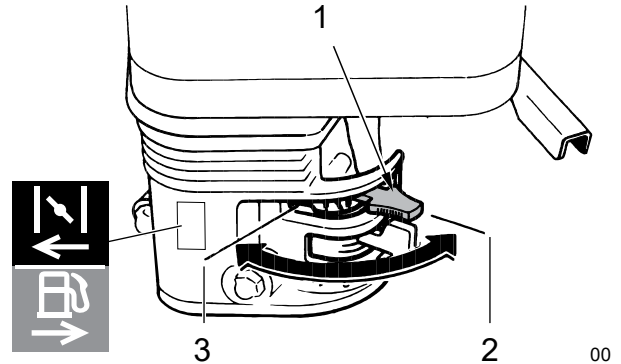

00

**Fig. 32 – Choke Lever**

1. Choke Lever
2. Choke OPEN
3. Choke CLOSED

3. Move the throttle lever away from the MIN. position, about 1/3 of the way toward the MAX position.

4. Turn the engine ignition switch ON.

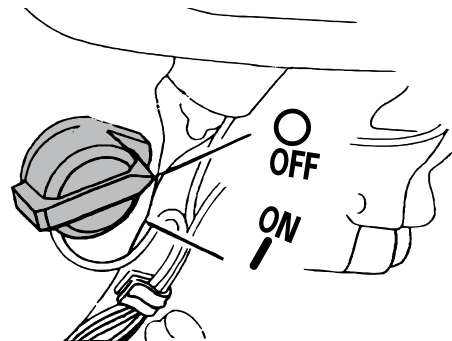

00187

**Fig. 33 – Ignition Switch**

5. Pull the starter grip out lightly until resistance is felt, then pull briskly in the direction of the arrow as shown below. Return the starter grip gently.

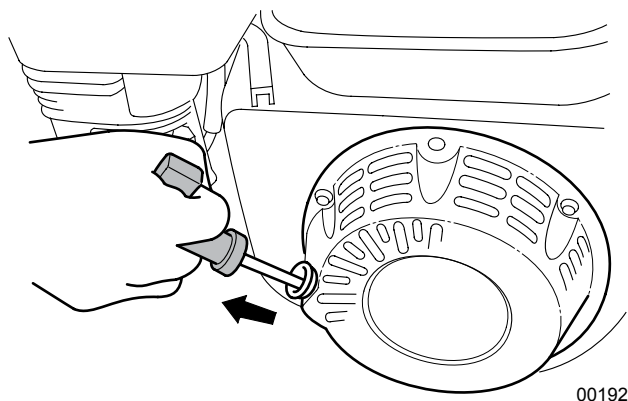

Fig. 34—Recoil Starter

**IMPORTANT!** Do not allow the starter grip to snap back against the engine. Return it gently to prevent damage to the starter.

6. Leave the engine operating at low throttle for a few minutes to allow it to warm up. Gradually push the choke control lever open (to the left) as the engine warms.

**IMPORTANT!** Engine should be warmed up before putting to work.

7. Once the engine is warmed, increase throttle as required. Adjust engine speed to preferred conveyor off-load speed.

## 5.9.7 Stopping Procedure

### In an emergency

- Turn the ignition switch OFF.
- Correct fault situation before restarting engine and resuming work.

Under normal conditions, use the following procedure. Refer to the engine manual for further information

1. Stop loading material onto the conveyor.
2. Decrease engine speed to **MIN**.
3. Turn the ignition switch **OFF**.

## 5.10 Transporting

### 5.10.1 Transport Safety

- Comply with provincial / state laws governing safety and transporting of machinery on public roads.
- Do not exceed a safe travel speed. Slow down for rough terrain and cornering.
- Do not transport or move the conveyor with the engine running (if equipped).
- Make sure the conveyor is hitched positively to the towing vehicle and a retainer is used through the hitch mechanism.
- Inspect wheel rims for dents or damage. Check wheel lug torque. Refer to table at the back of this manual.
- Inspect tires for cuts or damage. Check tire pressure and adjust if required. Refer to specification on the tire sidewall.
- Make sure the crank jack is raised and secured with the lynch pin.
- Clean off all debris from the conveyor.
- Never allow riders on the machine.
- Perform a final circle check before transporting.

1. Clear out all split wood from the conveyor.
2. Shut down the conveyor and the power source. Move the valve control lever to relieve pressure in the hydraulic lines.
3. Disconnect and cap the pressure and return lines. Place the hose ends in the conveyor hopper storage holes.

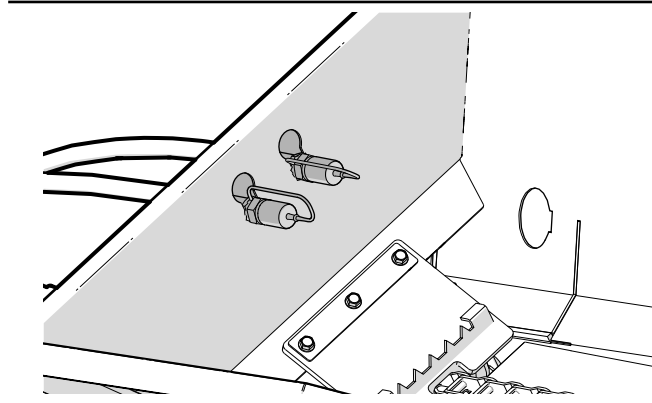
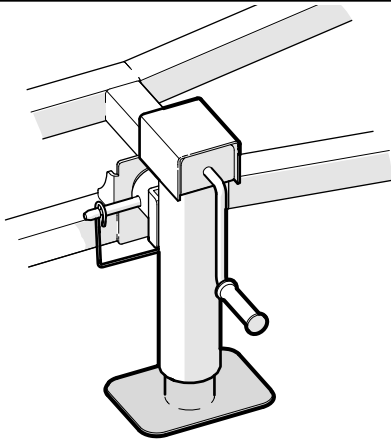

Fig. 35—Hose End Storage

- Clean off all dirt, mud, and debris.
- Rotate the crank jack to vertical and secure with the lynch pin. Raise the conveyor up to connect to the tow vehicle. Turn the jack back to the storage position once connected.



00460

**Fig. 36** – Crank Jack

- If equipped with the Accessory Hydraulic Power Pack, turn the fuel valve on the engine OFF when not in use or when transporting.

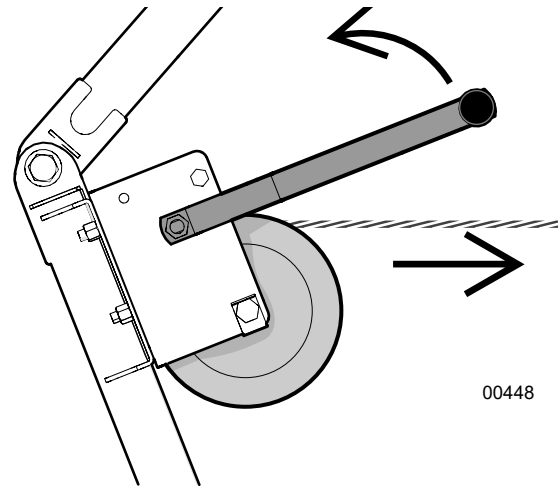

00448

**Fig. 38** – Lowering Conveyor

- Lock the hitch before towing.

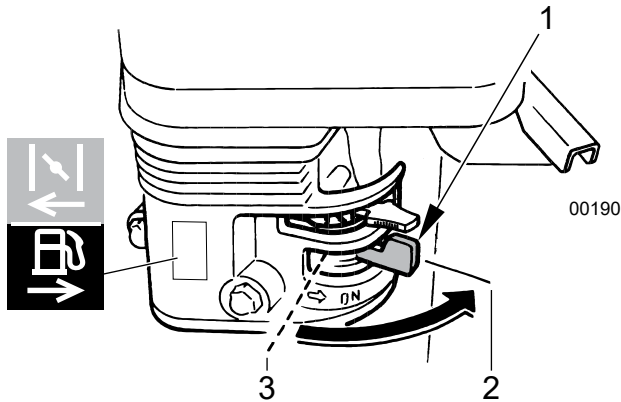

00190

**Fig. 37** – Fuel Valve Lever

1. Fuel Shut-off Valve Lever
2. ON Position
3. OFF Position

- Fully lower the conveyor. Turn the winch handle counterclockwise. No clicking sound is heard because the brake system is activated.

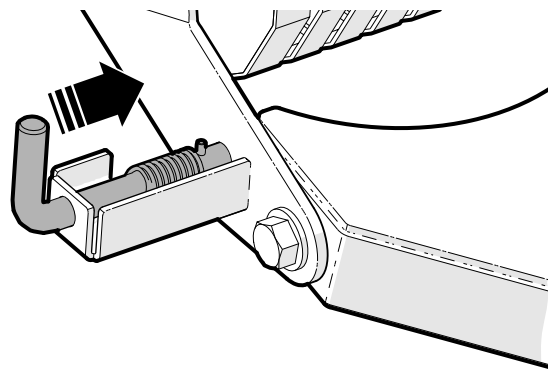

00459

**Fig. 39** – Hitch Lock Pin

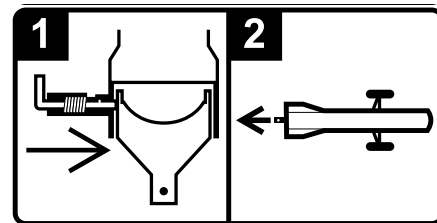

- To adjust conveyor tongue weight, see *page 23*.
- Use safety chains while traveling.
- Use safety flags as required to properly mark conveyor while traveling on roadways.
- Install toplink to lock top and bottom folding frames together.



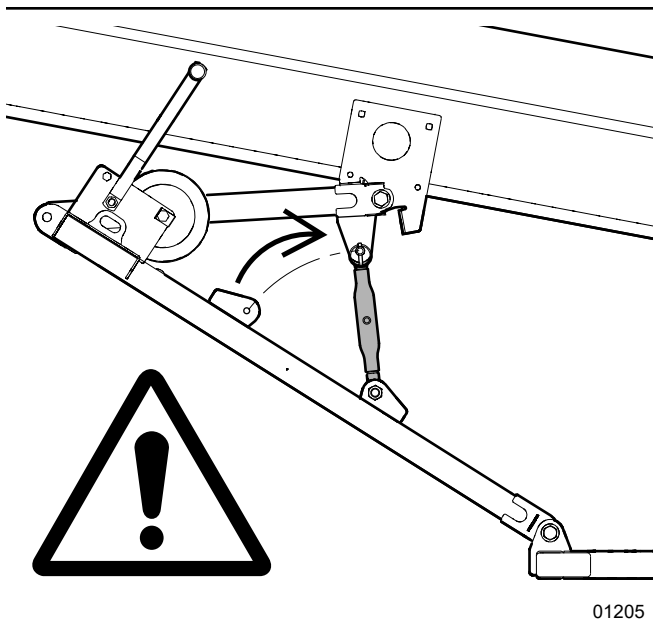

Fig. 40 – Toplink Installed

## 5.11 Storage

After the season's use or when the conveyor is not going to be used for a period, it should be thoroughly inspected and prepared before being put away.

Repair or replace any worn or damaged components to prevent any unnecessary down time at the start of next season.

### 5.11.1 Storing Conveyor

1. Clean off all dirt, mud, and debris.
2. Turn fuel valve OFF on the engine (if equipped). Add fuel stabilizer to the fuel tank.
3. Make sure the hose ends are capped and stored.
4. Grease conveyor drive bearings—one grease gun shot for each bearing. See *page 35*.
5. Select an area that is dry, level and free of debris to park the conveyor.
6. Store the conveyor away from human activity. Do not allow children to play on or around it.

### 5.11.2 Removing from Storage

1. Check air pressure in tires. See tire sidewall for rating.
2. Review and follow the Pre-operation Checklist. See *page 19*
3. Review safety and operation procedures. See *page 8*.

## 6. Service and Maintenance

### **WARNING!**

**Stop conveyor and disconnect power source before performing service or maintenance procedures.**

### 6.1 Maintenance Safety

Always place the machine in a safe service position before performing any service or maintenance work, storage preparation, or hooking / unhooking. This Safe Condition involves performing the following:

#### **SAFE CONDITION**

1. Empty the conveyor.
2. Shut off the conveyor drive by turning the flow control off.
3. Lower the conveyor fully until it is resting on the frame stops.

#### **Follow good shop practices:**

- Have at least two workers present when performing maintenance on this equipment. Never work alone in case an emergency should arise.
- Keep service area clean and dry.
- Never work under unsupported equipment.
- Use only genuine OEM replacement parts. The manufacturer is not responsible for injuries or damage caused by using non-approved parts or accessories.
- Make sure all safety shields and devices are re-installed after a maintenance or service procedure is finished.
- Do not use gasoline or diesel fuel when cleaning any parts. Use a regular cleanser.
- Use proper tools that are in good condition. Make sure the procedure is understood before performing any service work.

**IMPORTANT!** If equipped with the accessory power pack, refer to the engine manufacturer's manual in the manual for engine maintenance and service information.

### 6.2 Maintenance Schedule

Perform maintenance procedures at time shown or hour interval, whichever comes first.

#### **As Required**

Remove any entangled material from conveyor.

Check that all fasteners are tight.

#### **Every 50 hours or Annually**

Grease conveyor drive bearings.

See *page 35*

#### **Every 100 hours or Annually**

Check tire pressure.

See rating on tire sidewall

Clean machine. Remove debris and entangled material.

—

Check chain tension.

See *page 35*

Grease Hand Winch.

See *page 36*

### 6.3 Grease Points

Use a hand-held grease gun for all greasing. Pump one shot of grease slowly into each fitting.

- Use an SAE multi-purpose high temperature grease with extreme pressure (EP) performance. Also acceptable is an SAE multipurpose lithium-based grease.
- Wipe grease fitting with a clean cloth before greasing to avoid injecting dirt and grit.
- If fittings do not take grease, remove and clean them thoroughly. Replace grease fittings as necessary.

Location	Grease Points – Every 50 hours of operation or annually
1	Driven shaft bearings–1 per side

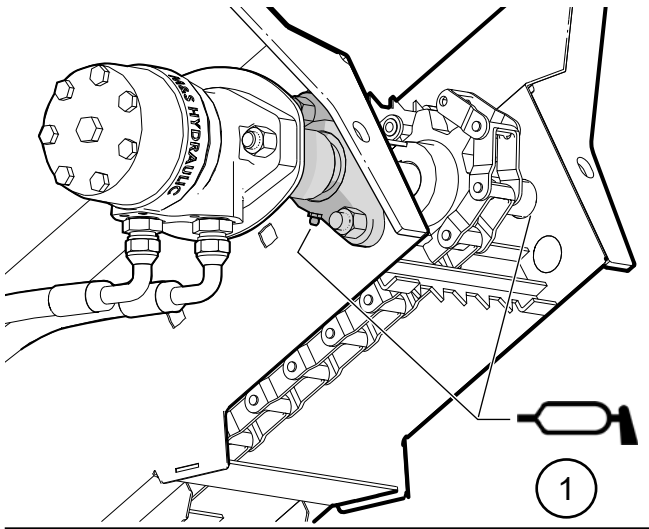

Fig. 42–Grease Points

**IMPORTANT!** Do not over grease. Pumping more than one shot from a grease gun into the bearings can push the grease out of the seals. Doing that repeatedly can damage the seals. Grease is not kept in, and dirt and moisture are not kept out.

### 6.4 Conveyor Chain Tension, Adjusting

The conveyor chain can stretch a slight amount and can require occasional adjustment. Care must be taken the chain is not over adjusted, as this adds pretension into the chain and reduces chain life.

**IMPORTANT!** The main requirement of chain adjustment is to remove slack from the chain (take up the clearances in each link). It is easy to over tighten the chain, so great care is needed!

Measure conveyor chain slack from the topside, inside the conveyor trough. Pull the chain up at the middle and measure dimension X. Adjust accordingly.

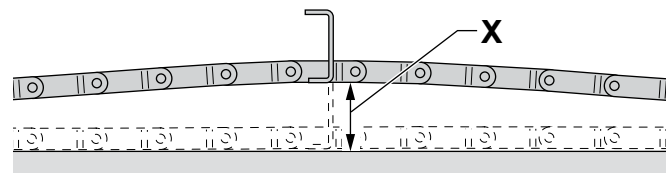

Ideal Conveyor Chain Slack (X)	
16 ft (4.8 m) Conveyor	X = 4" (10 cm)
24 ft (7.3 m) Conveyor	X = 6" (15 cm)

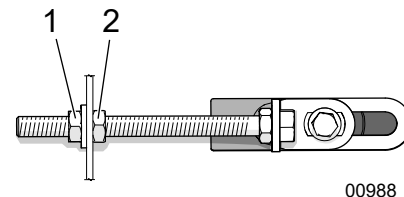

00988

Fig. 43–Chain tensioner

1. Loosen jam nuts (1).
2. Turn spring tensioner nut (2) clockwise to increase chain tension. **Make sure both sides of the conveyor are adjusted equally.**

**NOTE:** It may be necessary to tap the bolt lightly to get the spring to re-adjust the tension to the new setting.

3. Tighten jam nuts (1).

## 6.5 Hand Winch

**IMPORTANT!** Do not get oil or grease on the winch friction discs. The winch brake system cannot function properly if exposed to oil or grease.

- Apply a drop or two of SAE 30 engine oil to each bushing inside diameter and to the ratchet pawl pivot points.
- Maintain a thin layer of marine grease on the gear teeth and shaft threads.

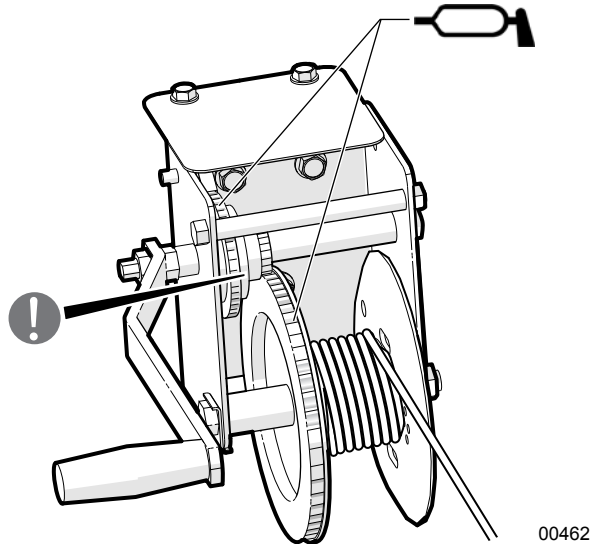

Fig. 44 – Hand Winch

## 6.6 Accessory Power Pack

**IMPORTANT!** Refer to the engine manufacturer's manual for engine maintenance and service information. The engine manual is in the manual tube on the side of the conveyor.

### 6.6.1 Fluids and Lubricants

#### 1. Engine Oil

SAE 10W-30 motor oil is recommended for general use in the engine, if equipped. Refer to the engine manufacturer's manual for maintenance and service information.

#### 2. Engine Fuel

The power pack engine is certified to operate on unleaded gasoline with a pump octane rating of 86 or higher (a research octane rating of 91 or higher).

#### 3. Storing Lubricants

Your machine can operate at top efficiency only if clean lubricants are used. Use clean containers to handle all lubricants. Store them in an area protected from dust, moisture, and other contaminants.

### 6.6.2 Maintenance Schedule

Perform maintenance procedures at time shown or hour interval, whichever comes first.

Every 8 hours or Daily	
Check fuel level	See page 28
Check engine oil level.	See page 28

Every 50 hours or Annually	
Clean engine air filter	See page 28

Every 100 hours or Annually	
Change engine air filter	See page 28
Change fuel filter	See engine manual

### 6.6.3 Hydraulic Oil, Changing

#### CAUTION!



**Risk of burns to exposed skin. Hydraulic oil becomes hot during operation. Hoses, lines, and other parts become hot as well. Wait for the oil and components to cool before starting any maintenance or inspection work.**

W028

Change the hydraulic oil in the reservoir at **100 hours** of operation or annually.

**IMPORTANT!** Change the return filter on the tank at the same time.

- Hydraulic oil type: **Dexron III ATF**.
- Hydraulic oil tank capacity: **4.6 US gal (17.5 L)**.

The reservoir drain plug is located on the underside of the tank. A 3/8" Allen wrench is required to remove it.

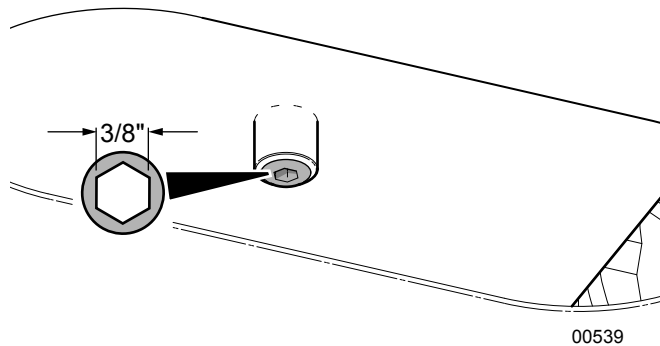

00539

**Fig. 45**—Hydraulic Tank Drain Plug

1. Have a drain pan ready of suitable capacity.
2. Clean the area around drain and remove the drain plug.
3. Allow the oil to fully drain, then flush the tank. Dispose of used oil in an environmentally acceptable method.
4. Re-install the drain plug.

### 6.6.4 Hydraulic Filter, Changing

1. The hydraulic system return filter is the spin-on type. Remove the filter and dispose of it in an environmentally friendly manner.

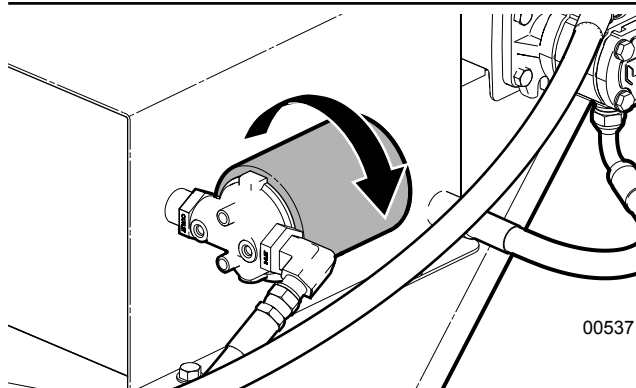

00537

**Fig. 46**—Hydraulic Oil Filter

2. Wet around the seal on the new filter with clean oil.



00538

**Fig. 47**—Oil the Seal

3. Turn the new filter on by hand until it is snug, then tighten another 1/4 turn. Wipe off any oil residue on the filter and filter head.
4. Fill the reservoir with clean, new oil. Verify the oil level using the dipstick. The oil level should be at the upper mark.

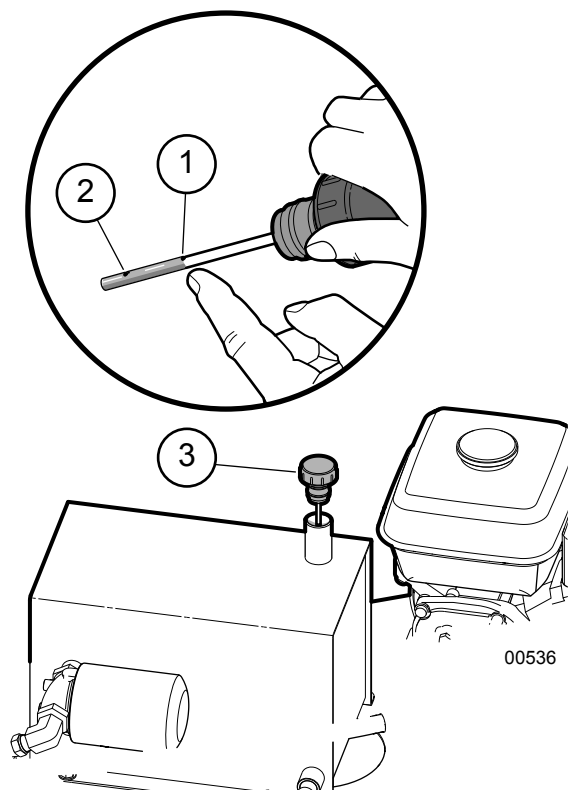

**Fig. 48**—Hydraulic Oil Level

- 1. Full Oil Level Mark
- 2. Low Oil Level Mark
- 3. Oil Level Dipstick

## 7. Troubleshooting

The following table lists some problems that may be encountered, with possible causes and suggested solutions.

If a problem persists after reading this Troubleshooting section, contact the local dealer, distributor or Wallenstein. Have the machine serial number ready.

### Engine related issues (if equipped)

Refer to the Honda® GX200 owner's manual found in the manual tube.

Problem	Cause	Solution
<b>The chain is winding on the sprocket.</b>	Too much slack in the chain	Adjust the chain length or distance between axle sprockets.
	Excessively worn sprocket. The chain and sprocket do not match.	Replace the chain and/or sprocket with the correct-sized part.
<b>Unusual noises.</b>	Excessive wear in the chain or sprocket.	Replace the chain or sprocket.
<b>Excessive wear at the inside of the chain's link plates or the teeth surfaces.</b>	Improper centering of the sprocket.	Correct the centering of the drive and driven sprockets.
	The chain is being pushed to the side.	Remove the debris or reason the chain is being pressed to the side.
<b>Chain does not move.</b>	Chain is frozen to conveyor trough or trough is jammed with material.	Free up the chain. Clear jammed material.

## 8. Specifications

Specifications subject to change without notice.

### 8.1 Machine Specifications

Conveyor Model		CT24
<b>Maximum Split Wood Pile Height</b>		13.5' (4.1 m)
<b>Trough</b>	<b>Length</b>	24' (7.3 m)
	<b>Width</b>	8" (20 cm) at Bottom Flared out to 20" (51 cm) at Top
	<b>Depth</b>	7" (18 cm)
<b>Power Source</b>		Hydraulic, 3 US gpm (11.3 Lpm) at 3000 psi (207 bar) Flow Control Valve Included Quick-disconnect fittings on Pressure and Return Lines
<b>Chain</b>	<b>Type</b>	662 Pintle Heavy Conveyor Chain
	<b>Drive</b>	Top Sprocket
	<b>Flight</b>	2" (5 cm) High Serrated
<b>Dimensions (see note)</b>	<b>Raised (L x W x H)</b>	260" x 74" x 174" (660 cm x 188 cm x 442 cm)
	<b>Lowered (L x W x H)</b>	307" x 74" x 83" (780 cm x 188 cm x 211 cm)
<b>Hitch</b>		Clevis Hitch (Optional 2" Ball Hitch)
<b>Tire Size</b>		5.30-12 LRC
<b>Total Weight (estimated)</b>		990 lb (449 kg)
<b>Wheels</b>		90° Swivel, Adjustable Axle

 **NOTE:** Maximum height shown. Width is variable with axle position (axle adjusts to modify tongue weight).

Hydraulic Power Pack Accessory	
<b>Engine</b>	HONDA® GX200
<b>Pump type</b>	Gear
<b>Control valve</b>	Single spool, open center
<b>Fuel tank capacity</b>	0.95 US gal (3.6 L)
<b>Hydraulic tank capacity</b>	4.6 US gal (17.5 L)



## 8.2 Common Bolt Torque Values

### Checking Bolt Torque

The tables shown give correct torque values for various bolts and capscrews. Tighten all bolts to the torque values specified in the table, unless indicated otherwise. Check tightness of bolts periodically.

**IMPORTANT!** If replacing hardware, use fasteners of the same grade.

**IMPORTANT!** Torque figures indicated in the table are for non-greased or non-oiled threads. Do not grease or oil threads unless indicated otherwise. When using a thread locker, increase torque values by 5%.

 **NOTE:** Bolt grades are identified by their head markings.

Imperial Bolt Torque Specifications						
Bolt Diameter	Torque Value					
	SAE Gr. 2		SAE Gr. 5		SAE Gr. 8	
	lbf•ft	N•m	lbf•ft	N•m	lbf•ft	N•m
1/4"	6	8	9	12	12	17
5/16"	10	13	19	25	27	36
3/8"	20	27	33	45	45	63
7/16"	30	41	53	72	75	100
1/2"	45	61	80	110	115	155
9/16"	60	95	115	155	165	220
5/8"	95	128	160	215	220	305
3/4"	165	225	290	390	400	540
7/8"	170	230	420	570	650	880
1"	225	345	630	850	970	1320



Metric Bolt Torque Specifications				
Bolt Diameter	Torque Value			
	Gr. 8.8		Gr. 10.9	
	lbf•ft	N•m	lbf•ft	N•m
M3	0.4	0.5	1.3	1.8
M4	2.2	3	3.3	4.5
M6	7	10	11	15
M8	18	25	26	35
M10	37	50	52	70
M12	66	90	92	125
M14	83	112	116	158
M16	166	225	229	310
M20	321	435	450	610
M30	1,103	1 495	1,550	2 100



### 8.3 Wheel Lug Torque

It is extremely important safety procedure to apply and maintain proper wheel mounting torque on your trailer axle. Torque wrenches are the best method to assure the proper amount of torque is being applied to a fastener.

Wheel lugs should be torqued before first road use and after each wheel removal. Check and re torque after the first 10 miles (16 km), 25 miles (40 km), and again at 50 miles (80 km). Check periodically thereafter.



#### WARNING!

**Wheel lug nuts must be installed and kept at the proper torque value to prevent loose wheels, broken studs, or possible separation of wheels from axle.**

- Start all lug nuts onto the threads by hand.
- Tighten lug nuts in stages, following the pattern shown in the Wheel Lug Nut Torque table.

Wheel Lug Nut Torque				
Wheel Size	Units	1st Stage	2nd Stage	3rd Stage
8"	lbf•ft N•m	12–20 16–26	30–35 39–45.5	45–55 58.5–71.5
12"	lbf•ft N•m	20–25 26–32.5	35–40 45.5–52	50–60 65–78
13"	lbf•ft N•m	20–25 26–32.5	35–40 45.5–52	50–60 65–78
14"	lbf•ft N•m	20–25 26–32.5	50–60 65–78	90–120 117–156
15"	lbf•ft N•m	20–25 26–32.5	50–60 65–78	90–120 117–156
16"	lbf•ft N•m	20–25 26–32.5	50–60 65–78	90–120 117–156

Wheel Lug Torque Pattern

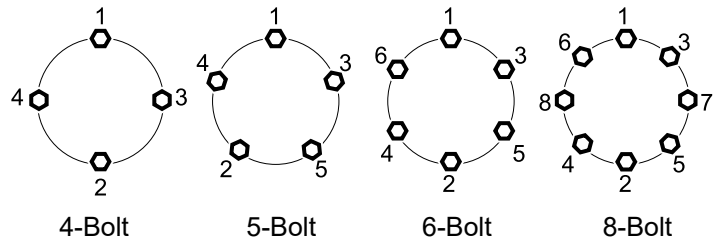

### Tightening Flare Type Tube Fittings

1. Check flare and flare seat for defects that might cause leakage.
2. Align tube with fitting before tightening.
3. Hand-tighten swivel nut until snug.
4. To prevent twisting the tube, use two wrenches. Place one wrench on the connector body and tighten the swivel nut with the second. Torque to values shown.

If a torque wrench is not available, use the FFFT (Flats From Finger Tight) method.

Hydraulic Fitting Torque					
Tube Size OD	Hex Size Across Flats	Torque value		Flats From Finger Tight	
		lbf•ft	N•m	Flats	Turns
3/16	7/16	6	8	2	1/6
1/4	9/16	11–12	15–17	2	1/6
5/16	5/8	14–16	19–22	2	1/6
3/8	11/16	20–22	27–30	1-1/4	1/6
1/2	7/8	44–48	59–65	1	1/6
5/8	1	50–58	68–79	1	1/6
3/4	1-1/4	79–88	107–119	1	1/8
1	1-5/8	117–125	158–170	1	1/8

Values shown are for non-lubricated connections.

## 9. Product Warranty



### LIMITED WARRANTY

Wallenstein products are warranted to be free of defects in materials and workmanship under normal use and service, for a period of

**Five Years for Consumer Use**

**Two Years for Commercial/Rental Use**

from the date of purchase, when operated and maintained in accordance with the operating and maintenance instructions supplied with the unit. Warranty is limited to the repair of the product and/or replacement of parts.

This warranty is extended only to the original purchaser and is not transferable.

Repairs must be done by an authorized dealer. Products will be returned to the dealer at the customer's expense. Include the original purchase receipt with any claim.

**This warranty does not cover the following:**

- 1) Normal maintenance or adjustments
- 2) Normal replacement of wearable and service parts
- 3) Consequential damage, indirect damage, or loss of profits
- 4) Damages resulting from:
  - Misuse, negligence, accident, theft or fire
  - Use of improper or insufficient fuel, fluids or lubricants
  - Use of parts or aftermarket accessories other than genuine Wallenstein parts
  - Modifications, alteration, tampering or improper repair performed by parties other than an authorized dealer
  - Any device or accessories installed by parties other than an authorized dealer
- 5) Engines. Engines are covered by the manufacturer of the engine for the warranty period they specify. For the details of your engine warranty, see your engine owner's manual. Information about engine warranty and service is also available in the FAQ section at [www.wallensteinequipment.com](http://www.wallensteinequipment.com)

# 10. Alphabetical Index

<b>A</b>	
Accessory Hydraulic Power Pack .....	24
Controls	
Control Valve Operation .....	26
Engine .....	25
Ignition Switch .....	26
Starter .....	26
Throttle Lever .....	25
Control Valve .....	26
Engine .....	36
Choke Lever .....	25
Engine Air Cleaner .....	28
Engine Fuel .....	36
Engine Oil .....	36
Fuel Level, Checking .....	28
Fuel Shut-off Valve .....	25
Pre-start Checks	
Engine Air Cleaner .....	28
Engine Oil Level Check .....	28
Fuel Level Check .....	28
Hydraulic Oil Level Check .....	29
Refueling .....	28
Refueling .....	28
Service and Maintenance .....	36
Adding Oil to the Tank .....	29
Engine Oil Level Check .....	28
Hydraulic Filter, Changing .....	37
Hydraulic Oil, Changing .....	37
Hydraulic Oil Level, Checking .....	29
Hydraulic Oil Tank Capacity .....	37
Maintenance Schedule .....	36
Starting .....	30
Stopping .....	31
Stopping in an Emergency .....	31
Air Cleaner Inspection .....	29
<b>B</b>	
Bolt torque .....	41
Break-in Period .....	19
<b>C</b>	
Checking Bolt Torque .....	41
Conveyor Angle Indicator .....	21
Conveyor Axle Position .....	23
Axle Location on Wheel Base Frame .....	23
Tongue Weight, Adjusting .....	23
Conveyor Chain Slack .....	35
Conveyor Chain Tension, Adjusting .....	35
Conveyor Set-up	
Height Adjustment .....	20
Hydraulic Connections .....	18
Pre-Operation Checklist .....	19
Rotate Wheels .....	22
Conveyor Setup .....	17
Conveyor Speed .....	20
Conveyor Tongue Weight .....	23
<b>D</b>	
Decals on the machine, types .....	6
<b>E</b>	
Engine Controls	
Choke Lever .....	25
Fuel Shut-off Valve .....	25
Ignition Switch .....	26
Recoil Starter .....	26
Throttle Lever .....	25
Engine Operating Instructions .....	27
Engine related issues .....	39
Engine Safety .....	27
Equipment Safety Guidelines .....	8, 9
<b>F</b>	
Familiarization .....	15
Conveyor Speed .....	20
Equipment Condition .....	15
Job Site Familiarization .....	15
Operator Orientation .....	15
To the New Operator .....	15
Training .....	15
Fluids .....	36
Foreword .....	2
Delivery Inspection Report .....	4
<b>G</b>	
Grease Points .....	35
<b>H</b>	
Height Adjustment .....	20
Hydraulic Connections .....	18
Hydraulic System Safety .....	10
<b>I</b>	
Informative Decals .....	6
Introduction .....	2
<b>L</b>	
Lowering Conveyor .....	21
Lubricants .....	36
<b>M</b>	
Machine Components .....	16
Machine Set-Up	
Height Adjustment .....	20
Maintenance Decals .....	6
Maintenance Schedule .....	34
8 hours or Daily .....	36
50 hours or Annually .....	34, 36
100 hours or Annually .....	34, 36
Measure conveyor chain slack .....	35
Move conveyor sideways .....	22
<b>O</b>	
Operating Instructions .....	19
Accessory Hydraulic Power Pack .....	24
Break-in Period .....	19
Connecting Hydraulic Lines .....	18
Conveyor Angle Indicator .....	21
Conveyor Axle Position .....	23
Conveyor Height, Adjusting .....	20
Pre-Operation Checklist .....	19
Rotating Wheels .....	22
Setting Conveyor Speed .....	20
Operating Safety .....	8

Operator Orientation .....	15
----------------------------	----

**P**

Personal Protective Equipment (PPE) .....	8
Pre-Operation Checklist .....	19

**R**

Raising Conveyor .....	20
Replacing Damaged Safety Signs .....	13
Rotate Conveyor Wheels .....	22

**S**

Safe Condition .....	8, 34
Safety .....	7
Equipment Safety Guidelines .....	8, 9
How to Install Safety Signs .....	13
Hydraulic System Safety .....	10
Operating Safety .....	8
Personal Protective Equipment (PPE) .....	8
Replacing Damaged Safety Signs .....	13
Safety Alert Symbol .....	7
Safety Training .....	34
Signal Words .....	7
Safety Alert Symbol .....	7
Safety Notice Decals .....	6
Safety Rules .....	8
Safety Sign Locations .....	11
Safety Signs	
Safety Sign Locations .....	11
Safety signs, installing .....	13
Safety Training .....	8, 34
Serial number .....	5
Service and Maintenance .....	34
Fluids and Lubricants .....	36
Grease Points .....	35
Hand Winch .....	36
Maintenance Schedule .....	34
Sign-off form .....	14
Specifications .....	40
Storing Conveyor .....	33
Storing Lubricants .....	36

**T**

Tongue Weight, Adjusting .....	23
Transporting .....	31
Troubleshooting Guide .....	39

**W**

Warranty .....	43
Wheel Lug Torque .....	42



A series of 20 horizontal lines spanning the width of the page, providing a template for writing.





[www.wallensteinequipment.com](http://www.wallensteinequipment.com)