

# OPERATOR'S MANUAL

---

Serial number 1101521 and up

## **BXMT32G** **Chipper / Shredder**

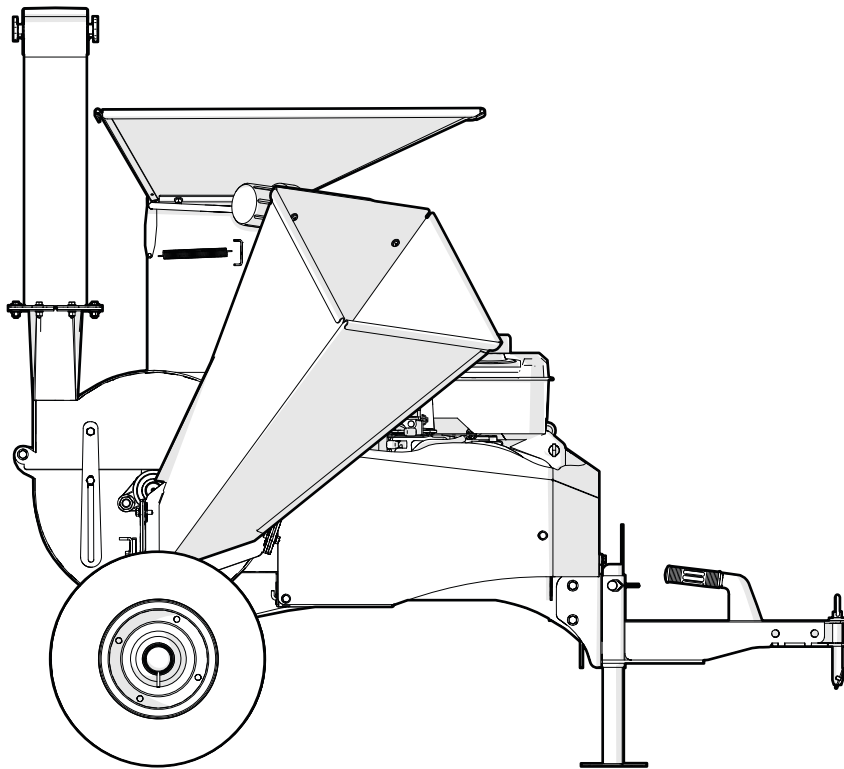

# Table of Contents

<b>1. Introduction</b> .....	<b>3</b>	<b>7. Transport</b> .....	<b>38</b>
1.1 Delivery Inspection Report .....	4	7.1 Transport Safety .....	38
1.2 Serial Number Location.....	5	7.2 Prepare the Machine for Transport .....	38
1.3 Types of Labels on the Machine.....	6	7.3 Connect to a Clevis Hitch .....	40
<b>2. Safety</b> .....	<b>7</b>	7.4 Disconnect from a Clevis Hitch .....	40
2.1 Safety Alert Symbol .....	7	7.5 Jack Stand .....	40
2.2 Signal Words .....	7	<b>8. Storage</b> .....	<b>42</b>
2.3 Why Safety is Important.....	7	8.1 Storage Safety .....	42
2.4 Safety Rules .....	8	8.2 Put the Machine in Storage .....	42
2.5 Equipment Safety Guidelines .....	9	8.3 Remove the Machine from Storage .....	42
2.6 Safe Condition .....	9	8.4 Replace the Engine Fuel .....	43
2.7 Safety Training.....	9	<b>9. Service and Maintenance</b> .....	<b>45</b>
2.8 Sign-Off Form .....	10	9.1 Service and Maintenance Safety.....	45
2.9 Work Site.....	11	9.2 Fluids and Lubricants.....	46
<b>3. Safety Labels</b> .....	<b>13</b>	9.3 Maintenance Schedule.....	47
3.1 Replace a Safety Label.....	13	9.4 Grease Points .....	48
3.2 Safety Label Locations.....	14	9.5 Engine Maintenance.....	51
3.3 Safety Label Definitions.....	17	9.6 Battery Maintenance .....	52
<b>4. Familiarization</b> .....	<b>20</b>	9.7 Tire Maintenance and Safety .....	53
4.1 New Operator .....	20	9.8 Drive Belt Maintenance .....	54
4.2 Training .....	20	9.9 Rotor Knife Maintenance.....	58
4.3 Operator Orientation.....	20	9.10 Ledger Knife Maintenance.....	59
4.4 Machine Components.....	21	9.11 Chop Block Maintenance .....	61
<b>5. Controls</b> .....	<b>22</b>	9.12 Shredder Knife Maintenance.....	62
5.1 Engine Controls .....	22	9.13 Clean the Machine .....	63
5.2 Discharge Chute .....	24	9.14 Safety Curtain Maintenance.....	63
5.3 Deflector.....	24	<b>10. Troubleshooting</b> .....	<b>64</b>
5.4 Shredder Gate.....	25	<b>11. Specifications</b> .....	<b>66</b>
5.5 Hitch Handle.....	25	11.1 Machine Specifications .....	66
<b>6. Operating Instructions</b> .....	<b>26</b>	11.2 Bolt Torque.....	67
6.1 Operating Safety .....	26	<b>12. Warranty</b> .....	<b>68</b>
6.2 Pre-Start Checklist.....	27	<b>13. Index</b> .....	<b>69</b>
6.3 Machine Break-In.....	27		
6.4 Engine Operation .....	28		
6.5 Start the Machine.....	32		
6.6 Stop the Machine.....	32		
6.7 Emergency Stop .....	32		
6.8 Set Up the Machine.....	33		
6.9 Operate the Chipper / Shredder .....	34		
6.10 Remove a Blockage.....	36		

# 1. Introduction

## **WARNING!**

**Do not start or operate the machine before you read this manual. Make sure that you fully understand all the safety, operation, and maintenance information before you operate the machine.**

**Keep this manual with the machine at all times and available for frequent reference.**

W034

### **Congratulations on your choice of a Wallenstein BXMT32G chipper / shredder!**

BXMT32G chipper / shredders are high-quality, rugged machines that are designed to cut brush and branches into consistent size wood chips. Each chipper / shredder is powered by a gas engine with centrifugal clutch that transfers power to the rotor through a drive belt. The rotor knives cut the wood material into wood chips that are blown out the adjustable discharge chute.

For safety, efficiency, and trouble-free operation of this Wallenstein product, anyone who uses or maintains the machine must read and understand the safety, operation, and maintenance information in this manual and the engine manufacturer's manual.

For information about the accessories, go to [WallensteinEquipment.com](http://WallensteinEquipment.com).

Keep this manual available for frequent reference and to give to new operators or owners. Call your local Wallenstein dealer or the distributor if you need assistance, information, or additional copies of the manuals.

Units of measurement in Wallenstein technical manuals are written as: US Customary (SI metric).

For support or service, contact your local Wallenstein Equipment dealer or distributor.

**Wallenstein Equipment Inc. • © 2023. All rights reserved.**

No part of this work may be copied, reproduced, replaced, distributed, published, displayed, modified, or transferred in any form or by any means except with the prior permission of Wallenstein Equipment Inc.

This manual is subject to change without notice. For the most current information, go to [WallensteinEquipment.com](http://WallensteinEquipment.com).



## 1.1 Delivery Inspection Report

### Wallenstein Chipper / Shredder

To activate the warranty, register your product at [WallensteinEquipment.com](http://WallensteinEquipment.com).

This form must be completed by the dealer at the time of delivery, and then signed by the dealer and customer.

I have received the product manuals and been thoroughly instructed about the care, adjustments, safe operation, and applicable warranty policy.

I have thoroughly instructed the customer about the equipment care, adjustments, safe operation, applicable warranty policy, and reviewed the manuals with them.

Customer

Dealer

Address

Address

City, State/Province, ZIP/Postal Code

City, State/Province, ZIP/Postal Code

(        )  
Phone Number

(        )  
Phone Number

Contact Name

Model

Serial Number

Delivery date

### Dealer Inspection Checklist

- \_\_\_\_\_ Rotor turns freely and the knife clearance is correct.
- \_\_\_\_\_ All cutting edges are sharp and in working condition.
- \_\_\_\_\_ Discharge chute and deflector move freely.
- \_\_\_\_\_ Shredder gate functions correctly.
- \_\_\_\_\_ All belts are aligned and the tension is correct.
- \_\_\_\_\_ All fasteners are torqued to the correct specifications.
- \_\_\_\_\_ All grease points are lubricated.
- \_\_\_\_\_ Engine clutch and rotor sheave align.
- \_\_\_\_\_ Engine starts and operates, and fluid levels are correct.
- \_\_\_\_\_ Battery is fully charged.
- \_\_\_\_\_ Tire pressure is correct (see the tire sidewall).
- \_\_\_\_\_ Tires are in working condition.
- \_\_\_\_\_ Purchased accessories are included, if applicable.
- \_\_\_\_\_ Operator's Manual is in the storage tube.

### Safety Checks

- \_\_\_\_\_ All safety labels are applied and legible.
- \_\_\_\_\_ Operating and safety instructions were reviewed.
- \_\_\_\_\_ All guards and shields are installed, and the covers are closed.
- \_\_\_\_\_ A retainer is installed through each hitch point.
- \_\_\_\_\_ Safety curtain is in the chipper hopper.
- \_\_\_\_\_ Jack stand functions correctly.

## 1.2 Serial Number Location

Always provide the model and serial number of your Wallenstein product when you order parts, or request service or other information. The product information plate location is shown in the following illustration.

**Record the serial number of your product here**

<b>Model</b>	<b>BXMT32G</b>
<b>Serial Number</b>	

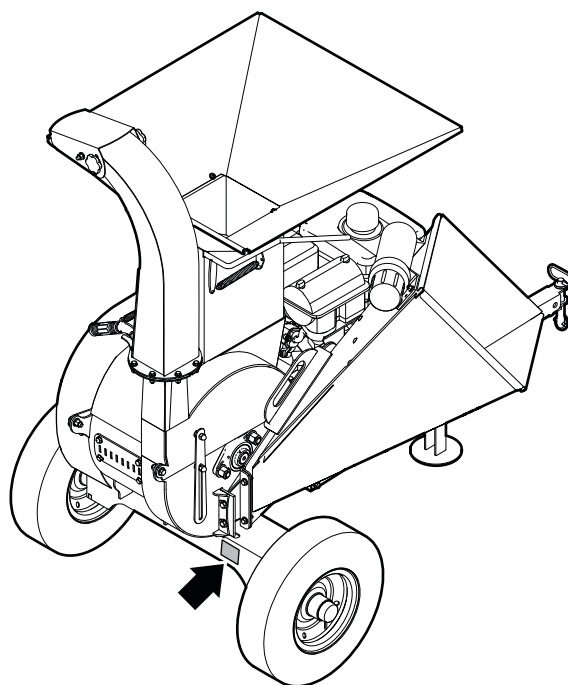

**Figure 1** – Product information plate location

## 1.3 Types of Labels on the Machine

There are different types of labels on your Wallenstein product. The labels are for safety, information, and product identification. This section explains what the labels are for and how to read them.

**Safety labels** are pictorial with a yellow background and have two panels. They can be vertical or horizontal.



**Mandatory action labels** are pictorial with a blue background and usually rectangular with single or multiple symbols. This label shows the type of personal protective equipment (PPE) that is necessary for safe operation.



**Information labels** are usually pictorial with a white background and the number of panels can be different. This type of gives information to the operator or shows the operation of a control.

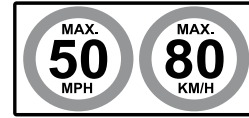

**Product labels** show the machine model and serial number. For more product information, scan the quick response (QR) code.



**Maintenance labels** have a green background and the number of panels can be different. This label shows the type of maintenance and how frequently it is necessary.



For safety label definitions, see *Safety Label Definitions* on page 17. For a complete illustration of labels and label locations, download the parts manual for your Wallenstein product at [WallensteinEquipment.com](http://WallensteinEquipment.com).

## 2. Safety

Read and understand all safety information before operating the machine.

### 2.1 Safety Alert Symbol

This Safety Alert Symbol means:

**ATTENTION! BE ALERT!**

**YOUR SAFETY IS INVOLVED!**

The safety alert symbol identifies important safety messages on the machine and in the manual.

When you see this symbol, be aware of the possibility of personal injury or death. Follow the instructions in the safety message.



### 2.2 Signal Words

The signal words **DANGER**, **WARNING** and **CAUTION** identify the severity of a hazard to anyone who uses the machine. The applicable signal word for each message was selected using the following guidelines:

#### **DANGER**

Identifies a hazardous situation that, if not avoided, **will** result in serious injury or death. This signal word is used to tell anyone who uses the machine about the most hazardous situations and machine components that cannot be guarded against.

#### **WARNING**

Identifies a hazardous situation that, if not avoided, **could** result in serious injury or death. This signal word includes hazards that occur when guards are removed and can be used to tell anyone who uses the machine about unsafe practices.

#### **CAUTION**

Identifies a hazardous situation that, if not avoided, **could** result in minor or moderate injury. It can also be used to tell anyone who uses the machine about unsafe practices.

**IMPORTANT** – Identifies a situation that could result in damage to the machine or property, but is not a personal injury hazard.



Provides additional information that is helpful.

### 2.3 Why Safety is Important

- Accidents disable and kill people.
- Accidents cost money.
- Accidents are preventable

**YOU** are responsible for the safe operation and maintenance of your Wallenstein product. **YOU** must make sure that you and anyone else who uses, maintains, or works around the machine is familiar with the operation and maintenance procedures and related **SAFETY** information contained in this manual. Obey the safety best practices included in this manual when you use your machine.

**YOU** are responsible for your own safety. Obey safety best practices to protect yourself and the people around you. Make these practices part of your safety program. Make sure that **EVERYONE** who uses this machine is familiar with the recommended operation and maintenance procedures, and obeys all the safety instructions. Most accidents can be prevented.

**Do not risk injury or death by ignoring safety instructions and best practices.**

## 2.4 Safety Rules

### **WARNING!**



**Wear the necessary hearing protection when you operate this machine. Prolonged exposure to loud noise can cause permanent hearing loss.**

W016

Wallenstein Equipment puts considerable effort into designing products that are safe to use; however, it is also the responsibility of the operator to use the equipment safely.

For safety information that is specific to machine operation, service, or maintenance, see the applicable section in this manual.

- It is the operator's responsibility to read, understand, and follow ALL safety and operating instructions in this manual.
- If you do not understand any part of this manual or need assistance, contact your local dealer, the distributor, or Wallenstein Equipment.
- Do not let anyone to use this machine until they have read this manual. The operator must have a thorough understanding of the safety precautions and how the machine works. Review the safety instructions with all users annually.
- Operators must be responsible, familiar with, and physically able to use the machine. Each operator must be trained before they use the machine. Before operation, evaluate the physical and/or mental limitations of each operator to make sure that they can use the machine safely. Do not let a child operate the machine.
- Make sure that all users understand the safety labels on the machine before they operate, service, adjust, or clean it. For safety label definitions, see *Safety Label Definitions on page 17*.
- Learn the controls and how to stop the machine quickly in the event of an emergency. For instructions, see *Emergency Stop on page 32*.
- Keep a first-aid kit available and know how to use the contents of it.
- Keep a fire extinguisher available and know how to use it.



- Wear the appropriate PPE when you operate, service, or maintain the machine. This includes, but is not limited to:
  - A hard hat.
  - Heavy gloves.
  - Hearing protection.
  - Protective shoes with steel toes and slip resistant soles.
  - Protective glasses, goggles, or a face shield.

- Prolonged exposure to loud noise can cause permanent hearing loss. Power equipment with or without a vehicle attached can often be noisy enough to cause permanent, partial hearing loss.



- Wear hearing protection on a full-time basis if the noise in the operator's position exceeds 80 dB. Noise over 85 dB on a long-term basis can cause severe hearing loss. Noise over 90 dB adjacent to the operator on a long-term basis can cause permanent, total hearing loss.
- Do not wear loose clothing, jewelry, or loose personal articles. Keep long hair tied up and covered. Loose items can get caught in moving parts and cause injury. Jewelry can ground a live electrical circuit which can cause injury and machine damage.
- Do not consume alcohol or drugs before or during machine operation. Alertness or coordination can be affected. When you take prescription medications, consult your doctor before you operate the machine.
- Only use the machine in daylight or good artificial light.
- Make sure that all guards and shields are installed, and the covers are closed. If removal is necessary for repair, replace them before you use the machine.
- Do not let anyone to ride on the machine during transport.
- Keep bystanders a minimum of 20 ft (6 m) from the discharge area. Mark the discharge area with safety cones.
- Before you start the machine, make sure that the engine and machine are clear of all material.
- Do not touch hot engine parts, the muffler cover, hoses, the engine body, or engine oil during operation or after the engine stops. Contact with hot surfaces can cause burns.



## 2.5 Equipment Safety Guidelines

Safety is one of the main concerns in designing and developing equipment. However, every year many accidents occur which could have been avoided by a few seconds of thought and a more careful approach to handling equipment.

Obey the following precautions to avoid hazards. Make sure that anyone who works with you obeys them as well.

- Replace safety or instruction labels that are not readable or are missing. For locations and explanations, see *Safety Labels on page 13*.
- Do not modify the equipment in any way. Unapproved modification can result in serious injury or death. In addition, unapproved modification can cause incorrect operation and decrease the life of the machine. Unapproved modification voids the warranty.
- Make sure that the machine is correctly stationed, adjusted, and in working condition.
- Keep the machine free of accumulated grease and debris to prevent fires and machine damage.
- Make sure that the discharged wood chips do not interfere with the safe operation of the machine.
- Look for and avoid overhead hazards (for example; branches, cables, and electrical wires).
- Do not exceed the limitations of the machine. If the machine is does not operate normally or you feel unsafe, stop the machine!

## 2.6 Safe Condition

References are made to **safe condition** throughout this manual. Safe condition means that you put the machine in a state that makes it safe to service or maintain.

**Before you start any service or maintenance, do the following:**

### SAFE CONDITION

1. If the machine is connected to a tow vehicle, set the tow vehicle's parking brake, stop the engine, and remove the ignition key.
2. Stop the machine.  
For instructions, see *Stop the Machine on page 32*.
3. Disconnect the engine spark-plug wire and keep it away from the spark plug.
4. Remove all material from the chipper hopper and shredder hopper.
5. Wait until the engine and machine are cool.

## 2.7 Safety Training

An untrained operator can cause serious injury or death to themselves or others. Review the safety instructions with all users annually. The *Sign-Off Form on page 10* can be used to keep a training record.

- When someone does not understand the operation of a machine, they can create dangerous situations very quickly. Operators must understand the safety information in this manual and the safety labels that are on the machine.
- The owner has the responsibility to provide instruction to anyone who is going to operate the machine. This machine is dangerous to anyone who is unfamiliar with its operation.
- If the machine is loaned or rented, it is the owner's responsibility to make sure that, before anyone uses the machine, every operator does the following:
  - Reads and understands this manual.
  - Receives instruction in the safe and correct use of the machine.
  - Understands and knows how to set the machine to a **Safe Condition**.  
For instructions, see *Safe Condition*.



## 2.9 Work Site



**The operator must be fully familiar with the work site before starting work. It is the operator's responsibility to prevent unsafe situations and make every effort to prevent accidents.**

W112

### 2.9.1 Select a Work Site

Select a safe work area and machine location:

- The ground should be firm and level.
- Make sure that there is a sufficient amount of space and clearance for the operator, the machine, and the wood chip discharge.
- Remove all stones, branches, or hidden obstacles that might cause a tripping, hooking, or snagging hazard.
- Make sure that there are no overhead hazards such as branches, cables, or electrical wires.
- Select a location for the discharged wood chips. Make sure that the wood chips do not interfere with the safe operation of the machine.

### 2.9.2 Create a Safe Work Area

Read and obey the instructions for safe operation of the machine.

Keep bystanders and workers safe from hazards. Obey the following guidelines:

- Use safety cones to identify the work zone perimeter. The work zone perimeter should be a minimum of 20 ft (6 m) away from any hazard in the work zone. The area outside the work zone perimeter is the safe zone. For more information, see *Figure 2 on page 12*.
- Do not let people approach the work zone during machine operation. Everyone must signal and make eye contact with the operator before they approach the work zone
- Keep all bystanders in the safe zone. Do not let bystanders in the work zone.
- Only the operator can let people enter the work zone. The operator must make sure that it is safe for a person to enter the work zone.
- When there are two or more workers, they must agree on a system of hand-signals to use for communication.
- The operator must make eye contact with coworkers and use the agreed system of hand signals. The operator must always be aware of their coworkers and know where they are.

A safe work area is divided into two zones:

**1. Safe Zone**

The safe zone is the area outside the work zone perimeter. All people who are not directly involved with the work can be in this area. There are minimal hazards in the safe zone.

**2. Work Zone**

The work zone is the area where the operator must be to operate the machine. People who are helping with the work and wearing the necessary PPE can be in this zone. The operator must know where all the people in the work zone are. The operator must make eye contact with people before they enter the work zone. There are possible hazards in the work zone.

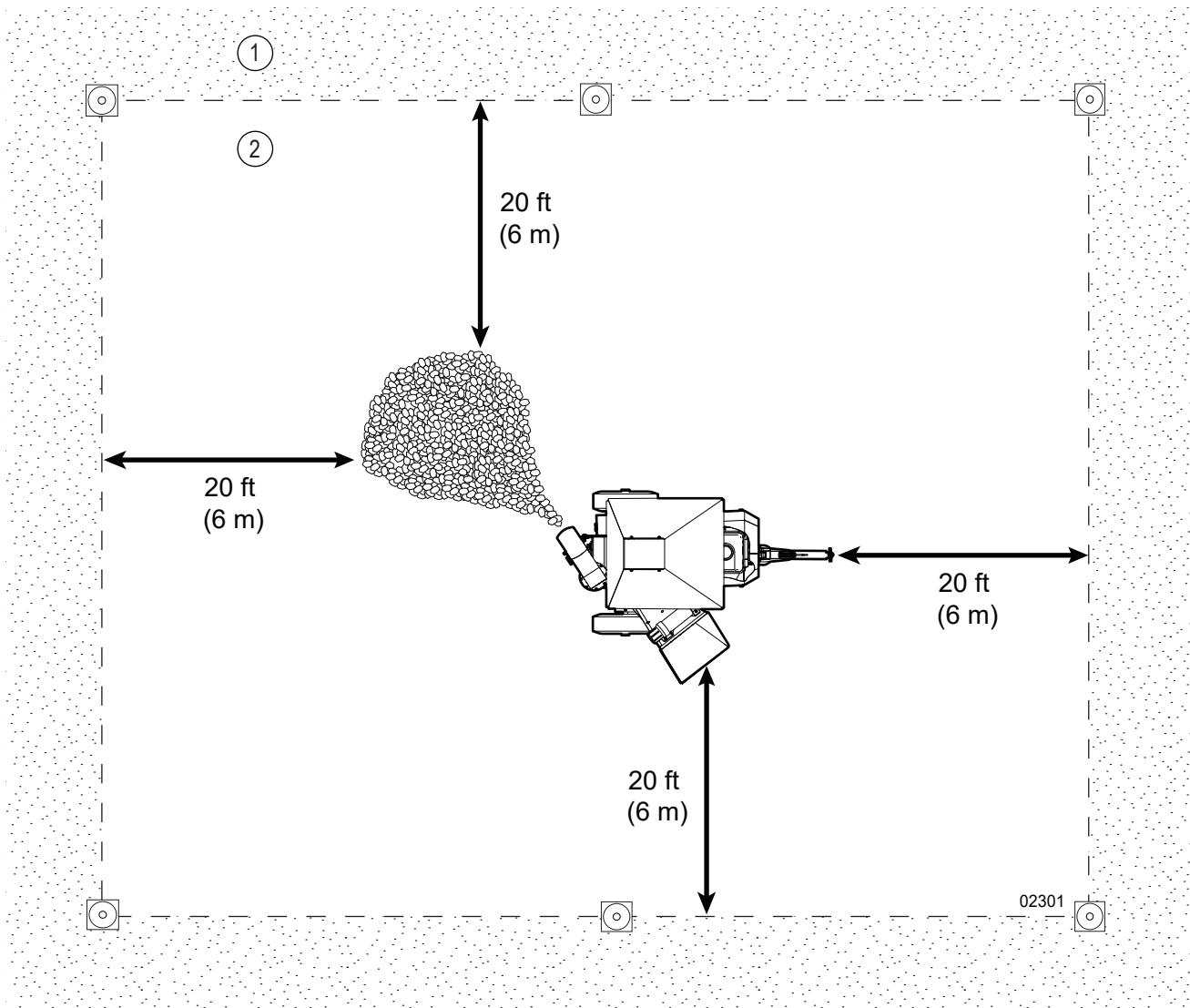

Figure 2—Example of a safe work area

## 3. Safety Labels

### WARNING!

Replace all safety labels that are missing, damaged, or illegible. If a component is replaced and it has a safety label on it, apply a safety label to the new component. Operating the machine with missing, damaged, or illegible safety labels puts the operator at risk of serious injury or death.

W100

Learn what the safety labels mean and know the safety hazards. A safety label can be vertical or horizontal. Vertical safety labels have a top panel and a bottom panel. Horizontal safety labels have a left side panel and a right side panel. The top or left side panel shows the safety alert (possible hazard), and the bottom or right side panel shows the action message (how to prevent illness, injury, or death).

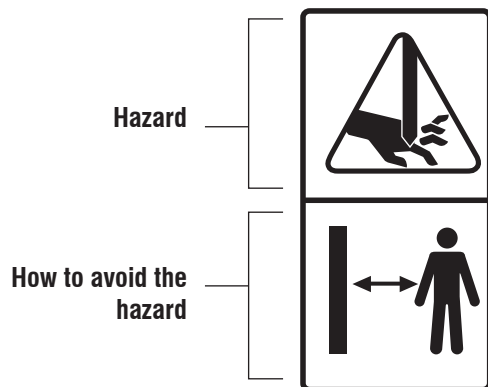

**Think SAFETY! Work SAFELY!**

### 3.1 Replace a Safety Label

- Always replace safety labels that are missing or have become illegible. Replacement safety labels are available from your local Wallenstein Equipment dealer or distributor.
- Keep the safety labels clean and legible at all times.
- When a part that has a safety label on it is replaced, the correct safety label must be applied to the replacement part.

#### 3.1.1 Conditions

- The installation area must be clean and dry.
- The application surface must be clean and free of grease or oil.
- The ambient temperature must be above 50 °F (10 °C).

#### 3.1.2 Tool

Use a squeegee, plastic card, or similar tool to smooth out the label.

#### 3.1.3 Procedure

1. Identify the label location.
2. Peel the label off the backing paper.
3. Hold the label above the location where you are going to apply it. Align the edges of the label with an edge of the machine.
4. Start at one edge and carefully press the center of the adhesive side of the label onto the machine.
5. Use an appropriate tool to smooth the label. Work from one side to the other.
6. If there are small air pockets:
  - a. Use a pin to pierce the air pocket.
  - b. Use a piece of the label backing paper to smooth the air pocket.

### 3.2 Safety Label Locations

The numbers correspond with the *Safety Label Definitions* on page 17.

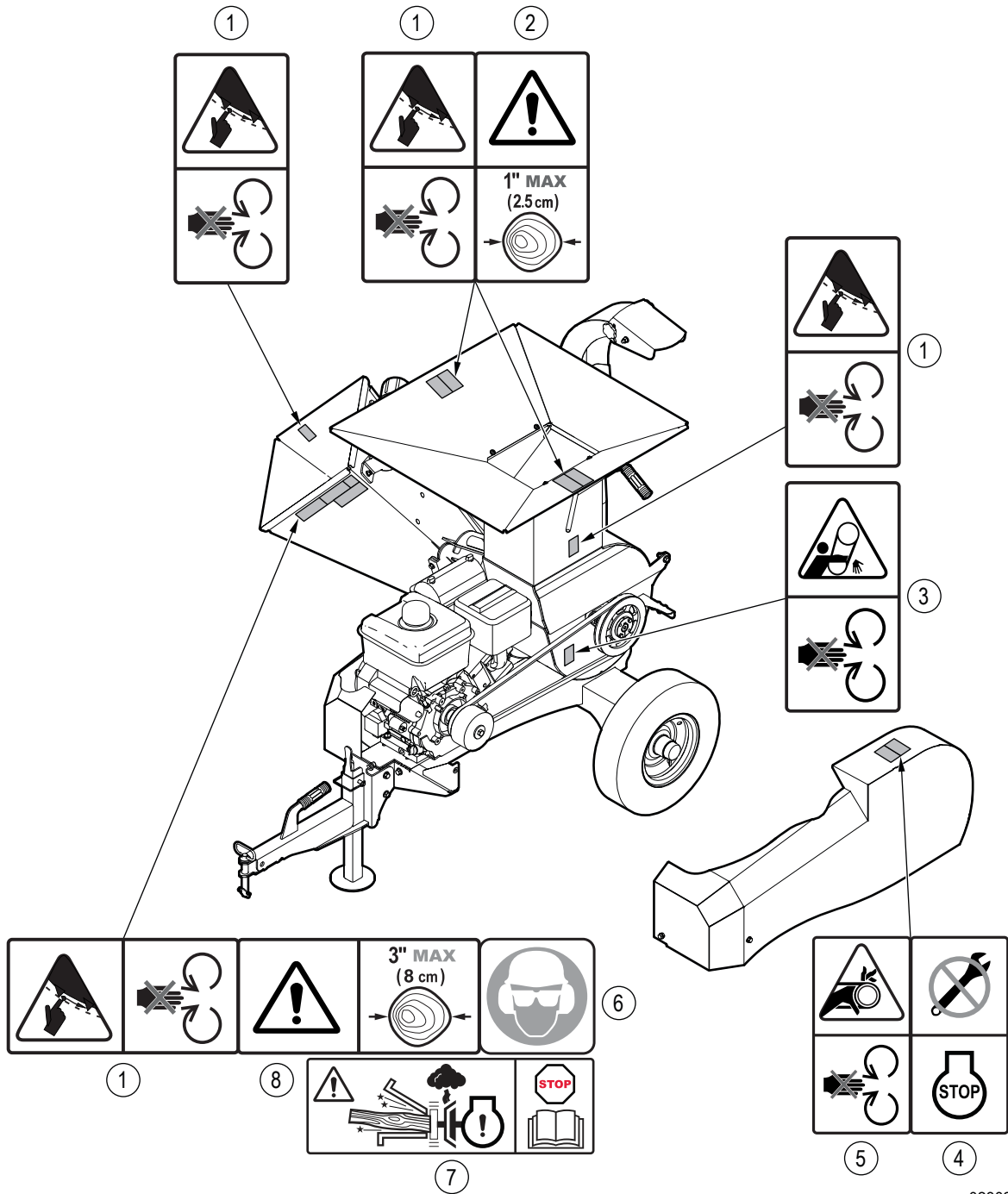

02302

Figure 3—Safety label locations - left-side front

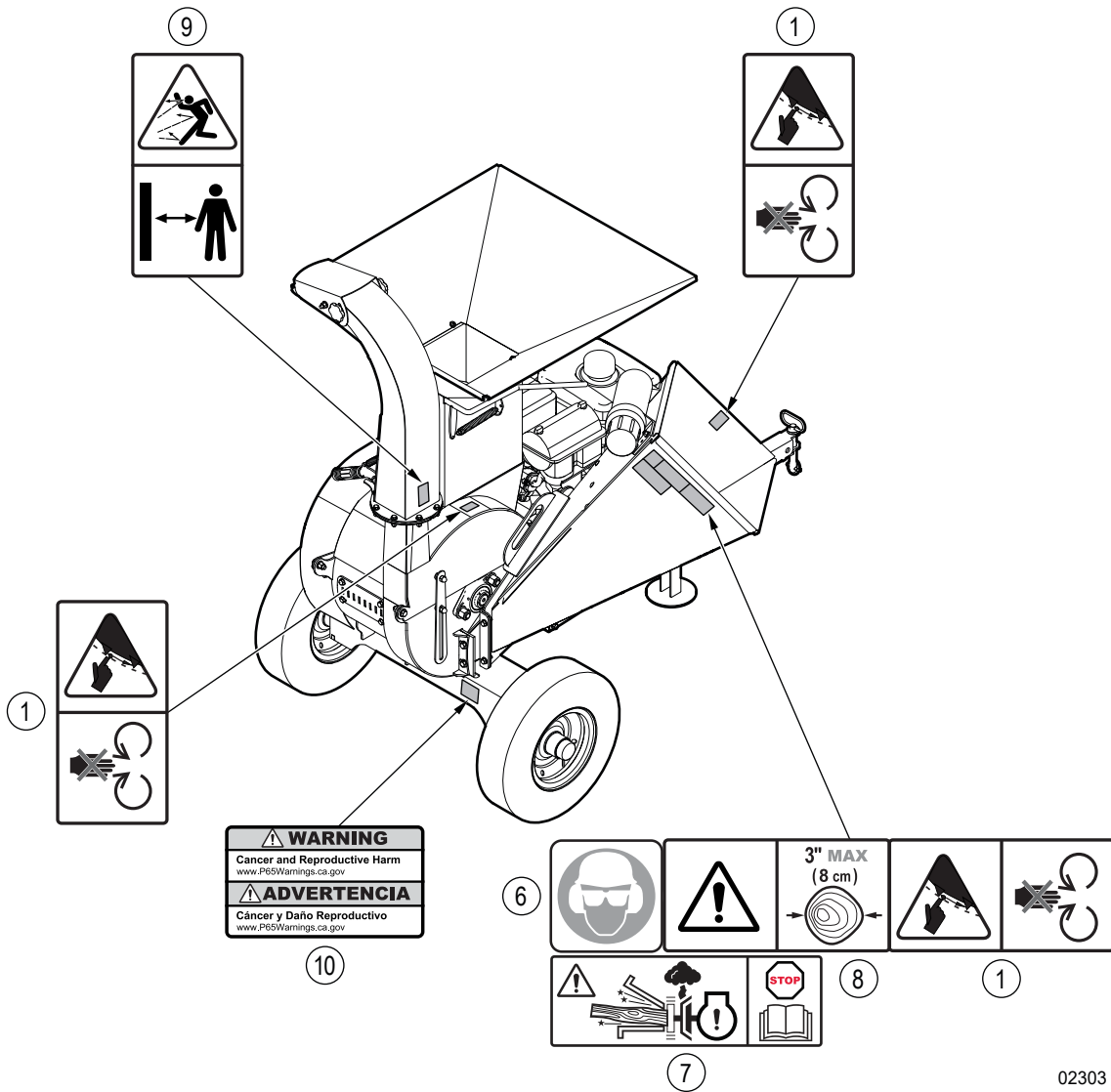
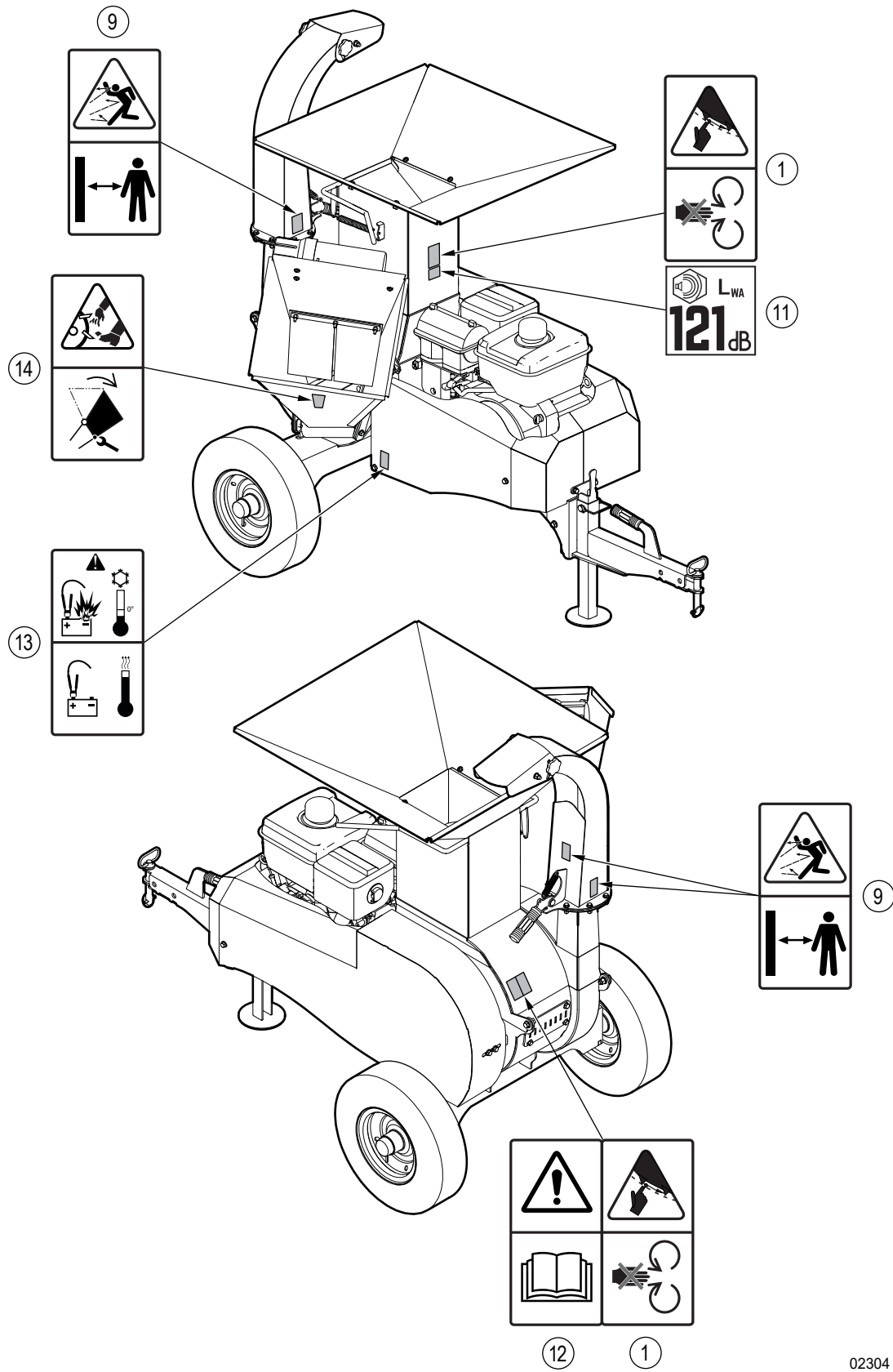

Figure 4—Safety label locations - right-side rear

02303



02304

Figure 5—Safety label locations - right-side front and left-side rear



### 3.3 Safety Label Definitions

#### 1. Warning!

##### Cut hazard

Sharp rotating parts can cut or sever fingers, hands, toes, or feet.

Keep hands and feet out of the chipper hopper or discharge chute when the machine is on and not in a safe condition.

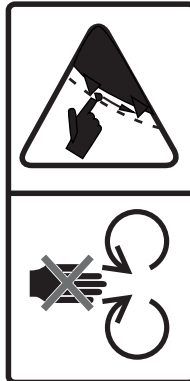

#### 2. Caution!

##### Machine damage and possible entanglement hazard

Oversize material will overload the machine, which can stall the engine or cause machine damage. If you try to force material into the machine, it can result in personal injury. Carefully remove oversize material from the machine.

Do not put material that is larger than 1" (2.5 cm) in diameter into the shredder hopper. Do not try to force material into the machine.



#### 3. Warning!

##### Entanglement, pinch, and crush hazards

Rotating parts can pull in, pinch, and crush fingers and hands. Install the guard when work is complete.

Keep your hands away from the drive belt. Turn off the machine and put it in a safe condition before service or maintenance. Wear heavy gloves and use caution when working in this area.



#### 4. Warning!

##### Turn off the machine before service or maintenance

Working on a machine that it is not in a safe condition can cause serious injury or death.

Stop the engine, remove the key, and disconnect the spark-plug wire before starting any service or maintenance procedures.

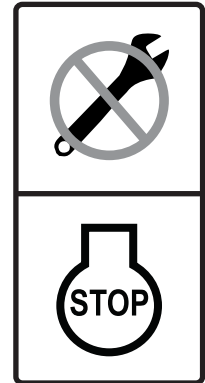

#### 5. Warning!

##### Entanglement, pinch, and crush hazards

Keep hands away from this area. Do not put your hands inside the guard.

Do not operate the machine with a guard removed. Make sure that all of the guards and shields are installed and the covers are closed before you start the machine.

Rotating parts that can entangle, pinch, or crush fingers and hands are exposed when the guard is removed.

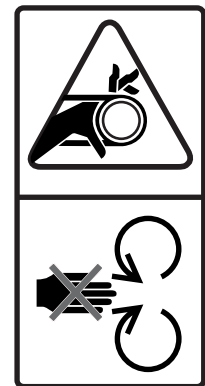

#### 6. Caution!

##### Wear the necessary PPE

For example:

- A hard hat.
- Heavy gloves.
- Hearing protection.
- Protective footwear with steel toes and slip resistant soles.
- Protective goggles or a face shield



**7. Information!**



Oversize material will overload the machine, which can stall the engine or cause machine damage.

Do not put oversize material into the machine. For information about the maximum material diameter, see this manual.

**8. Warning!**

**Machine damage and possible entanglement hazard**

Oversize material will overload the machine, which can stall the engine or cause machine damage. If you try to force material into the machine, it can result in serious injury from a fall or entanglement. Carefully remove oversize material from the machine.

Do not put material that is larger than 3" (8 cm) in diameter into the chipper hopper. Do not try to force material into the machine.



**9. Warning!**

**Impact, cut, and puncture hazards**

The machine releases wood chips fast enough to cause personal injury and property damage.

Stay away from the discharge chute and the area where the discharge chute is pointed. Do not point the discharge chute at people, animals, or structures.



**10. Warning!**

**Risk of cancer and reproductive harm**

The machine materials contain chemicals or machine operation can produce gases or dust that are identified by the state of California as causes of cancer, birth defects, or other reproductive harm.

This warning is a requirement of the state of California, USA to comply with Proposition 65: the Safe Drinking Water and Toxic Enforcement Act of 1986.



**11. Information!**

**Noise level hazard**

The noise declaration label shows the sound power (LWA) that the machine can make during operation. For this machine, the noise level can be up to 121 decibels at close range.



Noise exposure over 85 dB on a long-term basis can cause severe hearing loss. Exposure over 90 dB on a long-term basis can cause permanent, total hearing loss.

**12. Caution!**

**Read the Operator's Manual**

There is important safety information and instructions in the Operator's Manual.

Read all the safety information and instructions in the Operator's Manual. Know what all the safety labels mean.

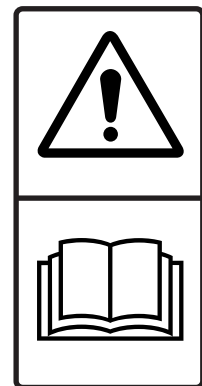

### 13. Warning!

#### Explosion hazard

Attempting to charge a frozen battery can cause it to explode. An explosion can cause serious injury or death from projectiles, extreme heat, chemicals, and loud noise.

Warm the battery to a minimum of 60 °F (16 °C) before charging it.

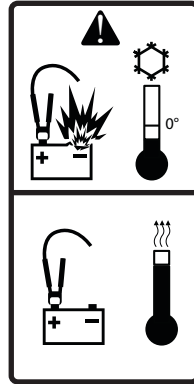

### 14. Warning!

#### Cut and severe hazards

Rotor knives that can cut or sever fingers or toes are exposed when the chipper hopper is removed.

Do not operate the machine with the chipper hopper removed.

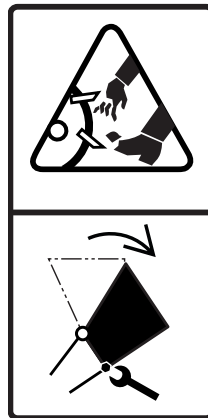

## 4. Familiarization

The Wallenstein BXMT32G chipper / shredder is designed to chip or shred small scrap lumber, small trees, brush, branches, leaves, and other wood material.

When wood material is put into the chipper hopper, the rotor pulls the material into the machine and cuts it into wood chips. When brush, bark, or leaves enter the machine through the shredder hopper, the shredder knives cut the material into mulch. The machine then blows the wood chips or mulch out the discharge chute. A Vanguard® engine provides power to the machine.

### 4.1 New Operator

#### **WARNING!**

**All operators must understand how to put the machine in a safe condition before they service, maintain, or store the machine. For instructions, see *Safe Condition* on page 9.**

**It is the responsibility of the owner and the operator to read this manual, and to train all operators before they work with the machine. Obey all safety instructions.**

**Only a fully trained operator is approved to use the machine.** A person who operates the machine without the correct training is a danger to themselves and others, and can cause property damage.

### 4.2 Training

Each operator must be trained in the correct operating procedures before using the machine. The sign-off form on page 10 can be used to keep a training record.

1. Teach the new operator the control locations, functions, and movement directions.
2. Put the machine in a large open area and let the new operator learn the control functions and machine responses.
3. After the new operator knows and is comfortable with the machine, they can start work.

### 4.3 Operator Orientation

**IMPORTANT!** When describing controls throughout this manual, the directions for left side, right side, front, and rear are determined when standing at the operator controls, facing the direction of forward machine travel.

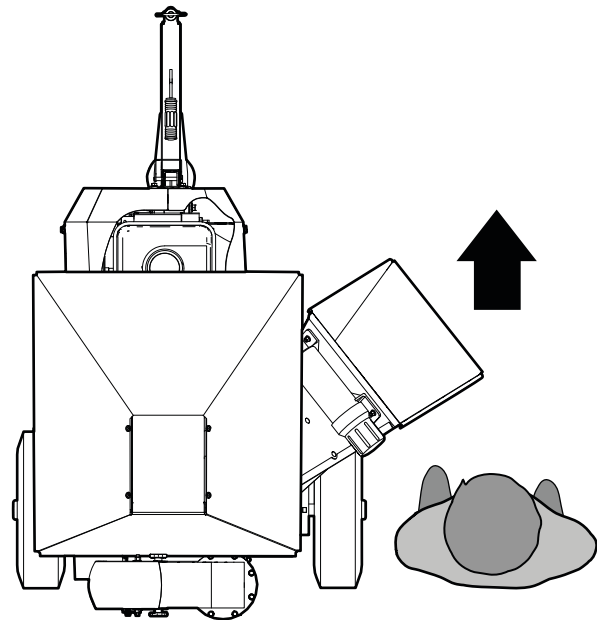

02299

**Figure 6**—Direction of forward machine travel

## 4.4 Machine Components

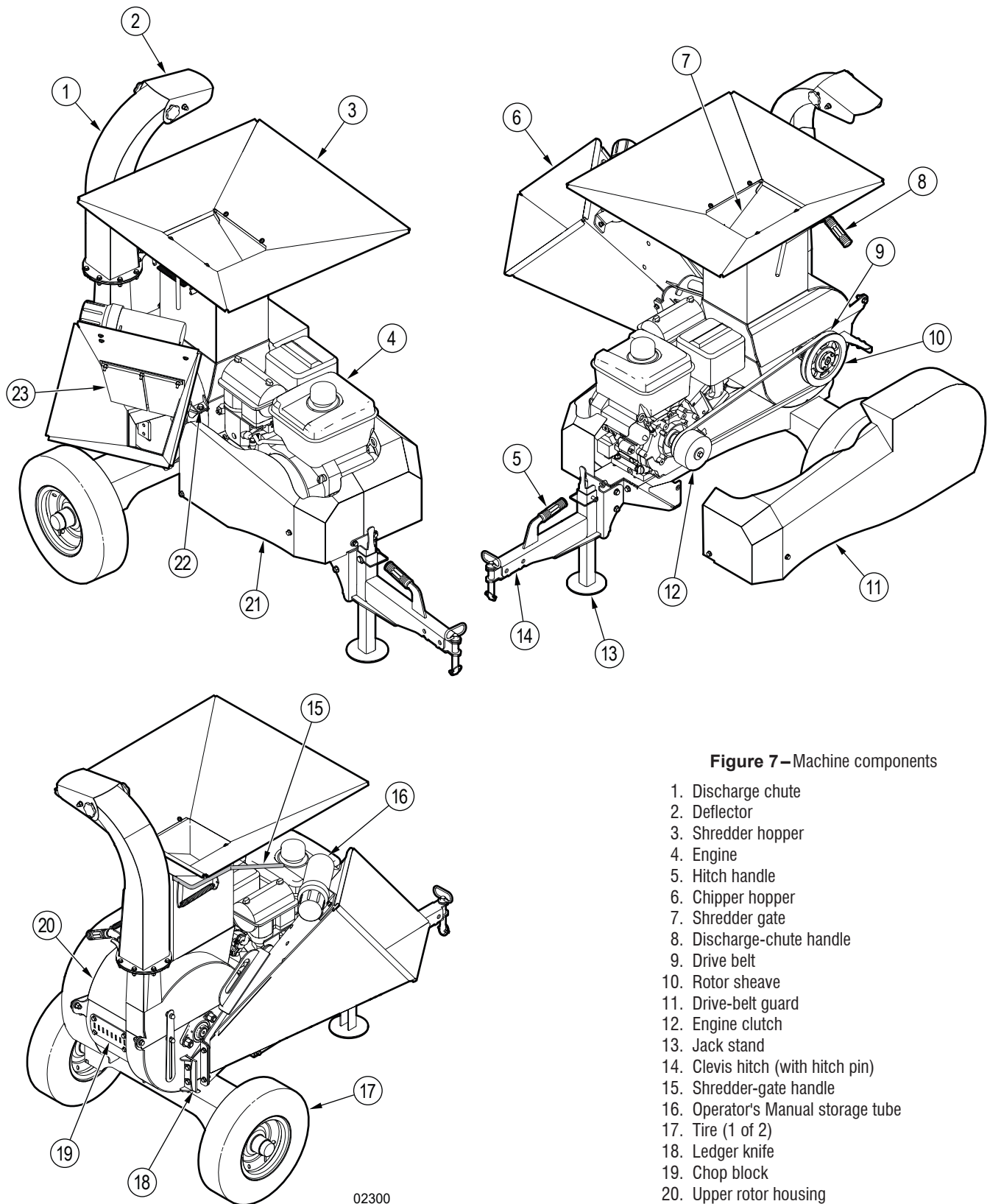

**Figure 7**—Machine components

1. Discharge chute
2. Deflector
3. Shredder hopper
4. Engine
5. Hitch handle
6. Chipper hopper
7. Shredder gate
8. Discharge-chute handle
9. Drive belt
10. Rotor sheave
11. Drive-belt guard
12. Engine clutch
13. Jack stand
14. Clevis hitch (with hitch pin)
15. Shredder-gate handle
16. Operator's Manual storage tube
17. Tire (1 of 2)
18. Ledger knife
19. Chop block
20. Upper rotor housing
21. Engine guard
22. Upper-rotor-housing fastener
23. Safety curtain

02300

## 5. Controls

### **WARNING!**

Do not operate the machine until you are thoroughly familiar with the position and function of the various controls. Read the operator's manual thoroughly. Your safety is involved!

W065

### 5.1 Engine Controls





#### **WARNING!**

Before you start the engine, read and understand the safety and operating information under *Engine Operation on page 28.*

**IMPORTANT!** For complete information about the engine controls, see the engine manufacturer's manual.

#### 5.1.1 Throttle Control and Fuel Shutoff

The throttle control and fuel shutoff lever has the following functions:

	<b>Fast</b> The engine speed is fast.
	<b>Slow</b> The engine speed is slow.
	<b>Fuel shutoff</b> The fuel-shutoff valve is closed.
	<b>Stop</b> The engine is stopped (off).

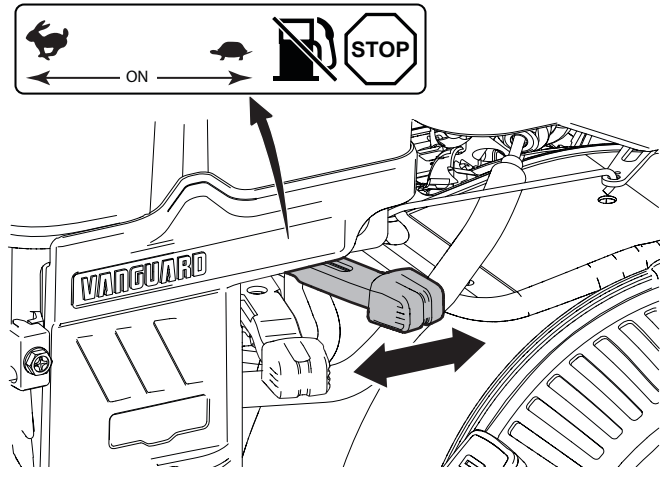



Figure 8—Engine throttle control and fuel shutoff

#### 5.1.2 Choke Control

The choke lever has the following functions:

	<b>Choke is closed</b> Close the choke to start a cold engine.
	<b>Choke is open</b> Open the choke when the engine is warm.

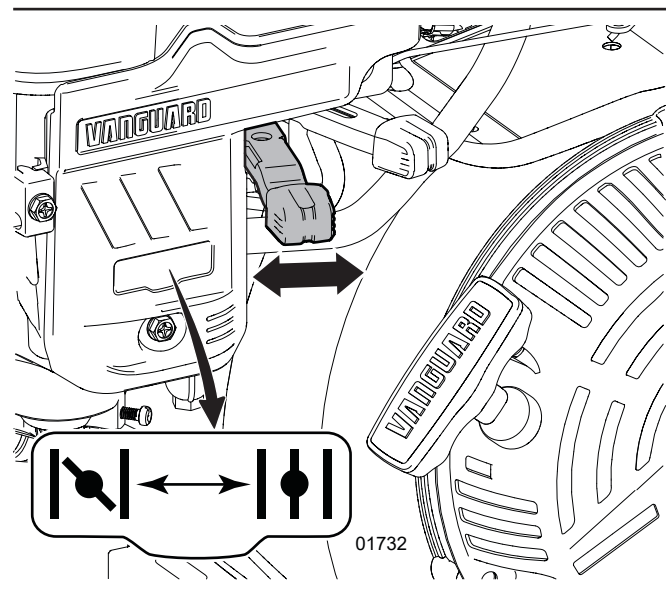

Figure 9—Engine choke control

### 5.1.3 Ignition Switch

#### **WARNING!**

The engine can cause serious bodily harm or death to a person who is not trained in the correct operation. Always remove the key and keep it in a safe location to prevent an unauthorized person from starting the engine.

W113

**IMPORTANT!** Long start cycles can reduce the life of the starter. Use short start cycles (five seconds maximum) and wait one minute between cycles.



The engine key only starts the engine, it does not stop it.

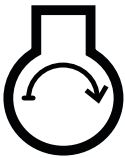

**Start**  
Turn the ignition switch to start the engine.

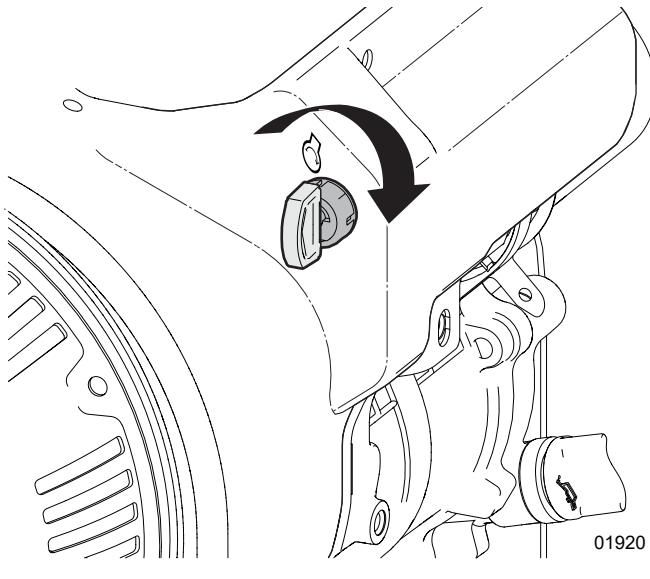

Figure 10—Ignition switch control

### 5.1.4 Rewind Start

#### **WARNING!**

Fast retraction of the starter cord (called kickback) pulls your hand and arm toward the engine faster than you can let go of the handle. Serious bodily harm (for example; bruises, sprains, fractures, and broken bones) can result.

When you start the engine, pull the starter cord slowly until you feel resistance, and then pull it rapidly to avoid kickback.

W102

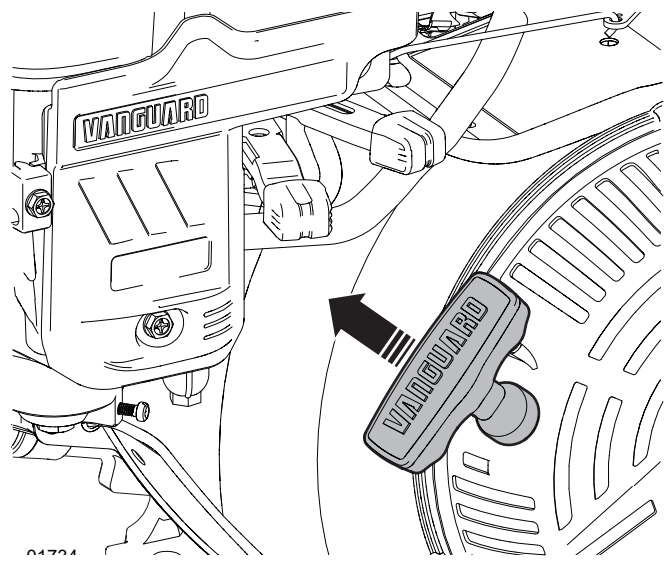

Figure 11—Rewind-start control

## 5.2 Discharge Chute

The discharge chute directs the wood chips in the selected direction. The discharge chute can be turned 310°. The latch-handle pin holds the discharge chute in position.

1. Push and hold the latch handle down until the pin disengages from the hole in the round plate.
2. Use the handle to turn the discharge chute to the position you want.
3. Release the latch handle.  
Make sure that the pin engages with a hole in the round plate to hold the discharge chute in position.

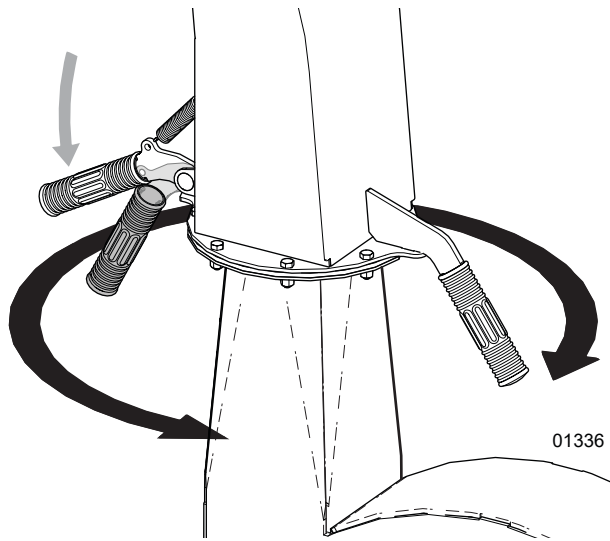

Figure 12—Turn the discharge chute

## 5.3 Deflector

The discharge chute has a deflector that directs wood chips toward the ground. Set the deflector higher to direct wood chips away from the machine. Set the deflector lower to direct wood chips closer to the machine.

Use the hand knobs that are on each side of the deflector to adjust the location of the wood chip pile.

1. Loosen the hand knobs (turn them counterclockwise).
2. Move the deflector to the position you want.
3. Tighten the hand knobs (turn them clockwise).

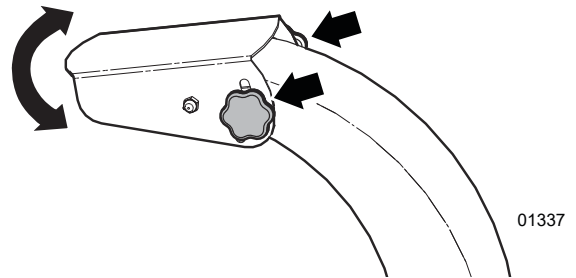

Figure 13—Adjust the deflector



## 5.4 Shredder Gate

The shredder gate keeps material in the shredder hopper until you open the shredder gate. A spring holds the shredder gate in the closed position.

<b>Open</b>	<p>Pull the shredder-gate lever down to open the shredder gate.</p> <p>Material that is in the shredder hopper falls into the rotor housing.</p>
<b>Closed</b>	<p>Release the shredder-gate lever to close the shredder gate.</p> <p>The spring lifts the shredder gate to the closed position.</p>

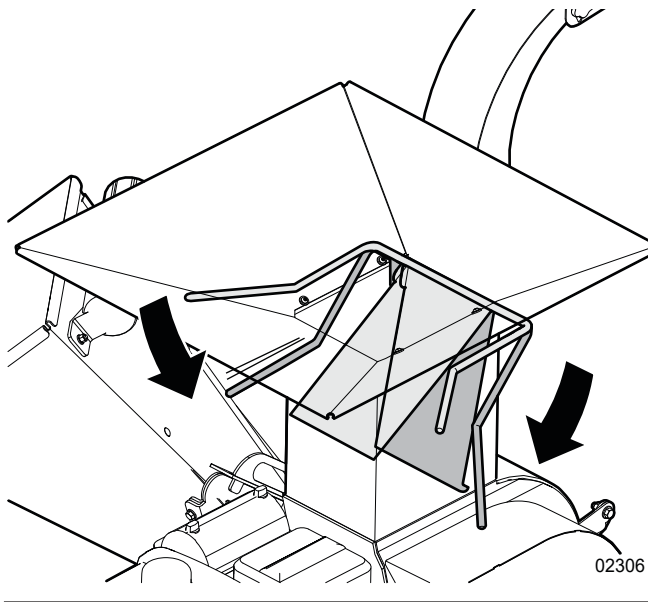

Figure 14—Open the shredder gate

## 5.5 Hitch Handle

Use the hitch handle to lift and move the front of the machine when you connect to a tow vehicle or disconnect from a tow vehicle.

For more information, see *Connect to a Clevis Hitch on page 40* or *Disconnect from a Clevis Hitch on page 40*.

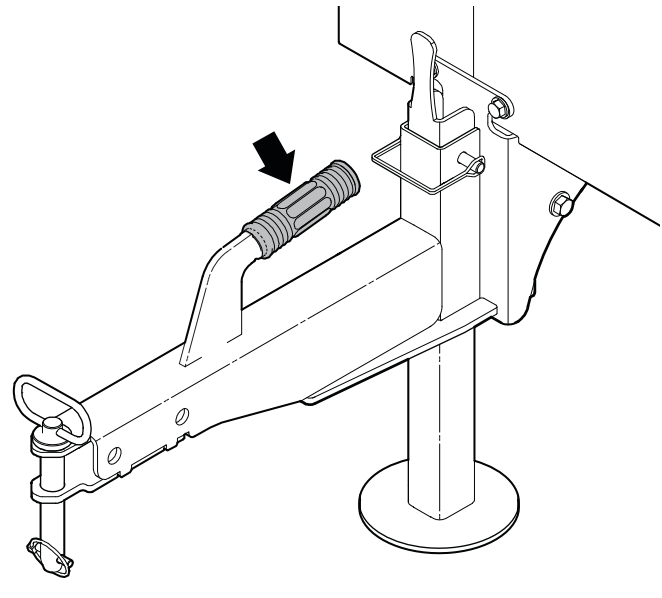

Figure 15—Hitch handle

## 6. Operating Instructions

The operator is responsible to be familiar with and obey all operating and safety procedures. Read and understand all the safety information in this manual before you operate the machine.

### 6.1 Operating Safety

#### WARNING!

Wear the personal protective equipment (PPE) that is necessary to do the work safely.

This includes, but is not limited to, a hard hat, hearing protection, a face shield, protective footwear, a respirator, and heavy gloves.

W101

#### WARNING!

Stay away from the discharge chute and the area where the discharge chute is pointed. Do not point the discharge chute at people, animals, or structures. The machine releases wood chips fast enough to cause personal injury and property damage.

W062

#### WARNING!

Do not reach into the chipper hopper. There are sharp knives that can trap, cut, and/or sever your fingers or hand. Use a stick or branch to pull material that does not move out of the discharge chute.

If there is a blockage, set the machine to a safe condition, and then remove the material.

W004

#### WARNING!

Always use the machine outdoors and park the machine in a position where the prevailing winds blow the engine exhaust away from the operator. Exhaust from the engine contains carbon monoxide (CO) that can accumulate to a dangerous level, even in an area with good air flow.

W006

**IMPORTANT!** Do not put metal objects, bottles, cans, rocks, glass, or other unapproved material into the machine. These items will damage the machine.

If these items get into the machine, set the machine to a safe condition before you remove them. Examine the machine for damage and loose parts.

- Read and understand this manual before you start the machine. Review all safety information annually.
- Park the machine in a clear location on dry, level ground. Do not operate the machine on a hillside or area that is cluttered, wet, muddy, or icy to prevent slips, trips, and falls.  
For more information, see *Work Site* on page 11.
- Keep the work area clean and free of debris.
- Only operate the engine in a location that has good air flow. Engine exhaust gases contain carbon monoxide (an odorless gas) that can cause asphyxiation.
- Attach all guards and shields, and close all covers before you start the machine.
- Do not move or transport the machine when the engine is on.
- Stop the engine before you leave the machine unattended.
- Cut large, curved branches into smaller, straighter sections. Some branches and brush move unpredictable directions when they enter the chipper hopper. Move away from the chipper hopper after you put material into the machine.
- Do not stand, sit, or climb on any part of the machine, especially while the engine is on.
- Do not operate the machine alone. Always have a minimum of two trained people:
  - There should be one operator and one spotter present during machine operation. The operator and spotter must know all the machine safety, controls, and operating functions.
  - The operator must be in control of the machine at all times. The spotter must stay outside of the hazard zone while the machine is operating.
- Keep bystanders a minimum of 20 ft (6 m) from the machine and wood chip release area. Mark the safe zone with safety cones.
- Do not reach into the chipper hopper or below the shredder gate. Keep your feet on the ground and make sure that you are stable when you put material into the chipper hopper.
- Keep your hands, feet, clothing, and long hair away from the chipper hopper. The chipper hopper can entangle hands, feet, clothing, and long hair, causing serious injury or death.

## 6.2 Pre-Start Checklist

Complete the following before you start the machine the first time and every time thereafter:

Items to Complete	✓
Read and obey the <i>Operating Safety on page 26</i> , <i>Engine Operation Safety on page 28</i> , and <i>Fuel Safety on page 29</i> .	
Check the drive belt tension and alignment. If necessary, adjust the drive belt. For instructions, see <i>Set the Drive Belt Tension on page 55</i> , and <i>Align the Drive Belt on page 56</i> .	
Check the condition and clearance of the twig breaker, rotor knives, and ledger knife. If necessary, adjust or replace them.	
Check the condition of the shredder knives and chop block. If necessary, adjust or replace them.	
Check the engine oil level. For instructions, see <i>Check the Engine Oil Level on page 31</i> . If necessary, add oil.	
Check the engine fuel level. For instructions, see <i>Check the Fuel Level on page 30</i> . If necessary, add fuel.	
Check the engine air filter. For instructions, see <i>Clean the Engine Air Filter on page 51</i> . If necessary, clean or replace the filter.	
Check the condition of the battery and electrical components. Make sure that all of the electrical components are in working condition and the connectors are connected. Replace damaged or corroded electrical components.	
Make sure that the machine is lubricated, as specified in the <i>Maintenance Schedule on page 47</i> .	
Remove anything that is entangled on the machine. For example, branches or vines.	
Remove all material from the rotor housing and discharge chute. For example, wood chips, bark, or leaves. Material in the rotor housing can cause the engine to stall when you start the machine.	
Make sure that the rotor bearings turn freely. If the bearings are damaged or do not turn freely, lubricate them or contact your local Wallenstein dealer to have them replaced.	
Make sure that all guards and shields are installed, and the covers are closed. If necessary, replace the guards, shields, or covers.	
Check the condition of the chipper hopper safety curtain. Replace the safety curtain if it is damaged. For more information, see <i>Safety Curtain Maintenance on page 63</i> .	
Check the condition of the shredder gate. Replace the shredder gate or spring if it is damaged. For more information, see <i>Shredder Gate on page 25</i> .	
Check the tire air pressure, and the wheels, hubs, and axle. See the side of the tire for the correct air pressure.	

Items to Complete	✓
Make sure that all the fasteners are installed and torqued to the correct specifications. For more information, see <i>Bolt Torque on page 67</i> .	
Make sure that the operator and spotter are wearing the necessary PPE. The PPE must be in good condition.	
Make sure that the operator and spotter are not wearing loose-fitting clothing or jewelry, and long hair is tied up.	
Make sure that there are no bystanders inside the work zone and the spotter is not near a hazard. For zone definitions, see <i>Work Site on page 11</i> .	

## 6.3 Machine Break-In

Before and during the first eight hours of operation, do the following tasks.

### 6.3.1 Before Initial Startup

1. Read and understand all safety information in this manual and the engine manufacturer's manual.
2. Review the *Machine Components on page 21*.
3. Review the operation and function of the *Controls on page 22*.
4. Complete the *Pre-Start Checklist on page 27*.

### 6.3.2 After One to Five Hours of Operation

- Check the drive belt tension and alignment. If necessary, adjust the drive belt. For instructions, see *Drive Belt Maintenance on page 54*.
- Check the condition and clearance of the twig breaker, rotor knives, and ledger knife. If necessary, adjust or replace them.
- Check the condition of the shredder knives and chop block. If necessary, adjust or replace them.
- After five hours of operation, change the engine oil. For instructions, see the engine manufacturer's manual.
- Check the engine oil level. If necessary, add oil. For instructions, see *Check the Engine Oil Level on page 31*.
- Check the engine fuel level. If necessary, add fuel. For instructions, see *Check the Fuel Level on page 30*.
- Make sure that all of the electrical components are in working condition and the connectors are connected.
- Check the condition of the rotor bearings. Make sure that the rotor bearings turn freely.
- Check the fasteners and make sure that they are torqued to the correct specifications. For more information, see *Bolt Torque on page 67*.

- Check the tire air pressure, and the wheels, hubs, and axle. See the side of the tire for the correct air pressure.
- Remove material that is entangled on the machine.
- Remove material from the rotor housing and discharge chute.

### 6.3.3 After Eight Hours of Operation

1. Complete the tasks listed under *After One to Five Hours of Operation*.
2. Check the engine oil level. If necessary, add oil. For instructions, see *Check the Engine Oil Level on page 31*.
3. Continue with the regular *Maintenance Schedule on page 47*.

## 6.4 Engine Operation

### CAUTION!

Before you start the engine, review the safety, operating, and maintenance instructions in the engine manual.

W019

### 6.4.1 Engine Operation Safety

#### WARNING!

Do not operate the engine indoors. Park the machine outdoors in a position where the prevailing winds blow the exhaust away from you.

Engine exhaust contains carbon monoxide (CO) that can quickly accumulate to a dangerous level. Carbon monoxide can cause illness, unconsciousness, or death.

W072

#### WARNING!

Keep the end of a disconnected battery cable away from the battery. Electricity can arc from the battery to the end of a battery cable and cause the battery to explode. An explosion can cause serious injury or death from heat, impact, and chemical hazards.

W115

### CAUTION!

Use a spark arrestor in areas where the forest, brush, or grass is dry to prevent forest fires. Check your local forest fire regulations and forest fire danger rating before you start the machine.

W114

**IMPORTANT!** In some regions, when an engine is used on any forest covered, brush covered, or grass covered unimproved land it is necessary by law to have a spark arrestor installed on the muffler. A spark arrestor traps exhaust particles that are expelled from the engine. It is the responsibility of the operator to comply with the local laws and regulations. To purchase a spark arrestor, contact your local Wallenstein dealer or distributor.

- Keep the cylinder fins and engine shrouds free of debris to prevent the engine from overheating.
- Keep the engine free of wood chips and other debris that can affect the engine speed.
- Use fresh fuel (less than three months old). Stale fuel creates deposits that cause the carburetor to be blocked and leak.
- Check the fuel lines and fittings on a regular basis for cracks or leaks. Replace damaged fuel lines or fittings if necessary.
- Store fuel away from all wood material.
- Only operate the engine in a location that has good air flow. Engine exhaust gases contain carbon monoxide (an odorless gas) that can cause asphyxiation.
- Do not put your hands or feet near moving parts.
- Do not check for a spark with the spark plug or spark plug wire removed.
- Do not choke the carburetor to stop the engine. When it is possible, gradually reduce the engine speed before you stop the engine.
- Do not tamper with governor springs, governor links or other parts that may increase the governed speed. Engine speed is selected by the original equipment manufacturer.
- Do not attempt to start the engine with the spark plug removed. If the engine floods, set the choke control to **Open** set the throttle control to **Fast**, and then try to start the engine again.
- Do not hit the flywheel with a hard object or metal tool. This can cause the flywheel to shatter during operation. Use the correct tools to service the engine.

- Do not touch a hot muffler, cylinder, or fins. Contact can cause burns. Wait for the machine to cool. Use a no-touch thermometer to measure the temperature.
- Do not operate the engine in the following situations:
  - When there is an accumulation of wood chips, dirt, or other combustible materials in the muffler area.
  - In an area where there is a fuel spill. Move the machine away from the spill until the fuel evaporates. Make sure that there are no sources of ignition in the area of the fuel spill.
  - With the air filter or air filter cover removed. This can damage the engine.
  - Without a muffler or heat shield. Inspect the muffler and heat shield on a regular basis. Replace a muffler or heat shield that is damaged.

## 6.4.2 Fuel Safety

### **WARNING!**



**Do not smoke or vape when you handle fuel. Fuel vapours can explode causing serious injury or death. Keep sparks, flames, or hot components away from fuel.**

W027

### **WARNING!**

**Fuel and vapors are very flammable and explosive. Fire or explosion can cause severe burns, bodily harm, or death. Keep fuel away from sparks, open flame, pilot lights, heat, and any other source of ignition.**

W116

### **CAUTION!**

**Fuel vapors are very toxic. Breathing fuel vapors can cause irritation, illness, or unconsciousness. Check the fuel level or add fuel to the engine outdoors or in an area that has good air flow.**

W117

- Engine fuel is highly flammable. Handle it carefully.
- Stop the engine and let it cool before you add fuel to the tank.
- Do not overfill the fuel tank.
- Carefully remove any spilled fuel, and then wait until any remaining fuel dries before you start the engine.
- After you add fuel to the tank, make sure that the fuel cap is tight.

### 6.4.3 Check the Fuel Level

**Check the engine fuel level before each use.**

Start work with a full fuel tank to decrease operating interruptions. Do not let the fuel tank become empty.

1. Park the machine on level ground.
2. Stop the machine.  
For instructions, see *Stop the Machine on page 32*.
3. Wait a minimum of five minutes for the engine to cool.
4. Turn the fuel cap counterclockwise to remove it.
5. Check the fuel level. The fuel tank is full when the fuel level is visible 1/2 inch (12 mm) below the filler neck. There must be room for fuel expansion.
6. Do one of the following:
  - If the fuel level is sufficient, install and the fuel cap and make sure that it is tight.
  - If the fuel level is not sufficient, add fuel to the tank.  
For instructions, see *Add Fuel to the Engine*.

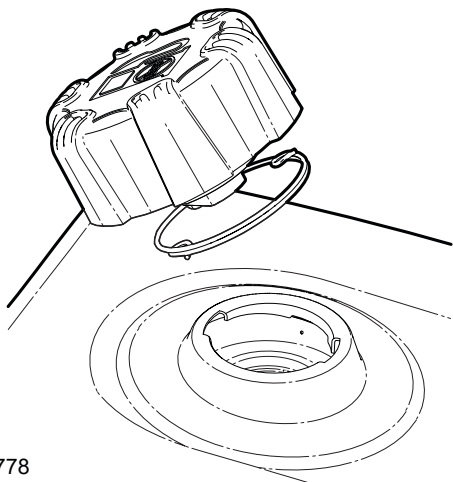

01778

**Figure 16**–Fuel cap

### 6.4.4 Add Fuel to the Engine

The engine needs clean, fresh, unleaded gasoline with a pump octane rating of 87 or higher (research octane number [RON] of 91 or higher). Gasoline with up to 10% ethanol (gasohol) is acceptable. For more information, see *Engine Fuel on page 46*.

For information about the fuel that is necessary for engine use at high altitudes, see the engine manufacturer's manual.

Fuel tank capacity: **1.59 US gal (6 L)**.

1. Stop the machine.  
For instructions, see *Stop the Machine on page 32*.
2. Wait a minimum of five minutes for the engine to cool.
3. Clean the area around the fuel cap.
4. Turn the fuel cap counterclockwise to remove it.
5. Use a clean funnel to add the correct type and amount of fuel to the tank. Add fuel until the fuel level is visible 1/2 inch (12 mm) below the filler neck. Leave room for expansion. **Do not overfill the tank.**
6. Carefully remove any spilled fuel, and then wait until any remaining fuel dries before you start the engine.
7. Install the fuel cap and make sure that it is tight.

## 6.4.5 Check the Engine Oil Level

**IMPORTANT!** For more information about engine oil, see the engine manufacturer's manual and *Engine Oil* on page 46.

**Operating the engine with a low oil level can cause engine damage that is not covered by the warranty.**



The engine must be in a level position for the dipstick to show the oil level correctly.

**Check the engine oil level before each use.**

1. Park the machine on level ground.
2. Stop the machine.  
For instructions, see *Stop the Machine* on page 32.
3. Remove the oil-level dipstick and clean it.
4. Fully insert the oil-level dipstick.
5. Remove the oil-level dipstick and check the oil level.  
The oil level is correct when the oil is visible on the dipstick from the end to the full (upper) mark.
6. Do one of the following:
  - If the oil level is correct, continue with step 7.
  - If the oil level is low, add oil until the oil level is at the full (upper) mark. For instructions, *Add Oil to the Engine* on page 31.
7. Install the oil-level dipstick and make sure that it is tight.

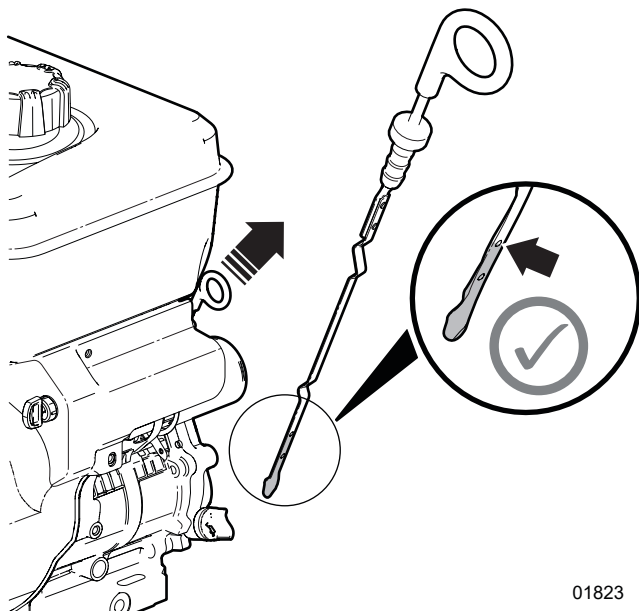

01823

Figure 17—Check the engine oil level

## 6.4.6 Add Oil to the Engine

**IMPORTANT!** For more information about engine oil, see the engine manufacturer's manual and *Engine Oil* on page 46.

The engine has three oil-fill locations. The two most accessible locations are shown in the following image. The third location is on the opposite side of the engine, below the dipstick.

1. Check the engine oil level to make sure that the oil level is low. For instructions, see *Check the Engine Oil Level* on page 31.
2. Turn the oil-fill cap counterclockwise to remove it.
3. Use a clean funnel to slowly add the correct type and amount of oil. **Do not overfill.**
4. Wait a minimum of one minute.
5. Remove the funnel, and then check the engine oil level.
6. Install the oil-fill cap and make sure that it is tight.

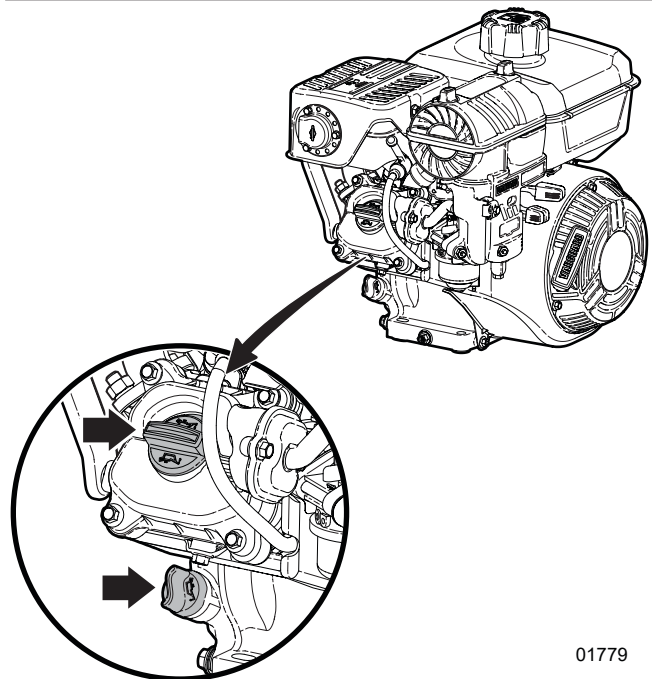

01779

Figure 18—Engine oil-fill locations

## 6.5 Start the Machine

### **WARNING!**

Before you start the machine, read and understand all of the safety information in this manual and the engine manufacturer's manual.

W118

### **WARNING!**

**Fast retraction of the starter cord (called kickback) pulls your hand and arm toward the engine faster than you can let go of the handle. Serious bodily harm (for example; bruises, sprains, fractures, and broken bones) can result.**

**When you start the engine, pull the starter cord slowly until you feel resistance, and then pull it rapidly to avoid kickback.**

W102

**IMPORTANT!** If the engine does not start after repeated attempts, contact your local dealer or go to [VanguardPower.com](http://VanguardPower.com).

Before you start the machine, see the information under *Controls on page 22* and *Engine Operation Safety on page 28*.

1. Complete the tasks described in the *Pre-Start Checklist on page 27*.
2. Set up the machine.  
For instructions, see *Set Up the Machine on page 33*.
3. Move the choke control to the **Closed** position.  
If the engine is warm, the choke can be moved to the **Open** position.
4. Move the throttle control to the **Fast** position.
5. Start the engine. Do one of the following:
  - **Electric start** – insert the key, and then turn the ignition switch to the **Start** position until the engine starts or for a maximum of five seconds.  
If the engine does not start, release the key. Wait for a minimum of one minute before you try again.
  - **Rewind start** – firmly grip the starter-cord handle, pull the starter cord slowly until you feel resistance, and then pull it rapidly.
6. As the engine warms up, move the choke control to the **Open** position.
7. Wait a minimum of three minutes for the rotor speed to increase.

## 6.6 Stop the Machine

**IMPORTANT!** Do not choke the carburetor to stop the engine. Choking the carburetor can cause damage to the engine.



The engine key does not stop the engine, it only starts the engine.

1. Stop putting material into the machine.
2. Wait for a minimum of 30 seconds to let all the material blow out of the machine.  
Material in the rotor housing can cause the engine to stall the next time you start the machine.
3. Move the engine throttle control to the **STOP** position to stop the engine and close the fuel shutoff valve.
4. Wait a minimum of one minute for the engine to decrease the rotor speed.
5. Remove the key.  
Keep the key away from unapproved users and children.

## 6.7 Emergency Stop

**In an emergency:**

1. Stop putting material into the machine.
2. Move the engine throttle control to the **STOP** position to stop the engine and close the fuel shutoff valve.
3. Remove the key and keep it with you.  
Do not let anyone start the machine until the emergency is resolved.



## 6.8 Set Up the Machine

### **WARNING!**

Always use the machine outdoors and park the machine in a position where the prevailing winds blow the engine exhaust away from the operator. Exhaust from the engine contains carbon monoxide (CO) that can accumulate to a dangerous level, even in an area with good air flow.

W006

1. Select a work site and set up a safe work area.  
For more information, see *Work Site on page 11*.
2. Do one of the following:
  - Disconnect the machine from the tow vehicle.  
For instructions, see *Disconnect from a Clevis Hitch on page 40*.
  - If more stability is necessary, leave the machine attached to the tow vehicle. Set the tow vehicle's parking brake, stop the engine, and then remove the key from the ignition.
3. Lower the jack stand to support the machine in a level position. The machine should be as level with the ground as possible.  
For instructions, see *Lower the Jack Stand on page 40*.
4. Turn the discharge chute to direct the wood chips away from the operator and in the direction of the wind.  
For instructions, see *Discharge Chute on page 24*.
5. Adjust the deflector to direct the wood chips further from or closer to the machine.  
For instructions, see *Deflector on page 24*.
6. Make sure that the upper rotor housing is closed and the fastener is tight.
7. Make sure that all of the guards and shields are installed and the covers are closed.

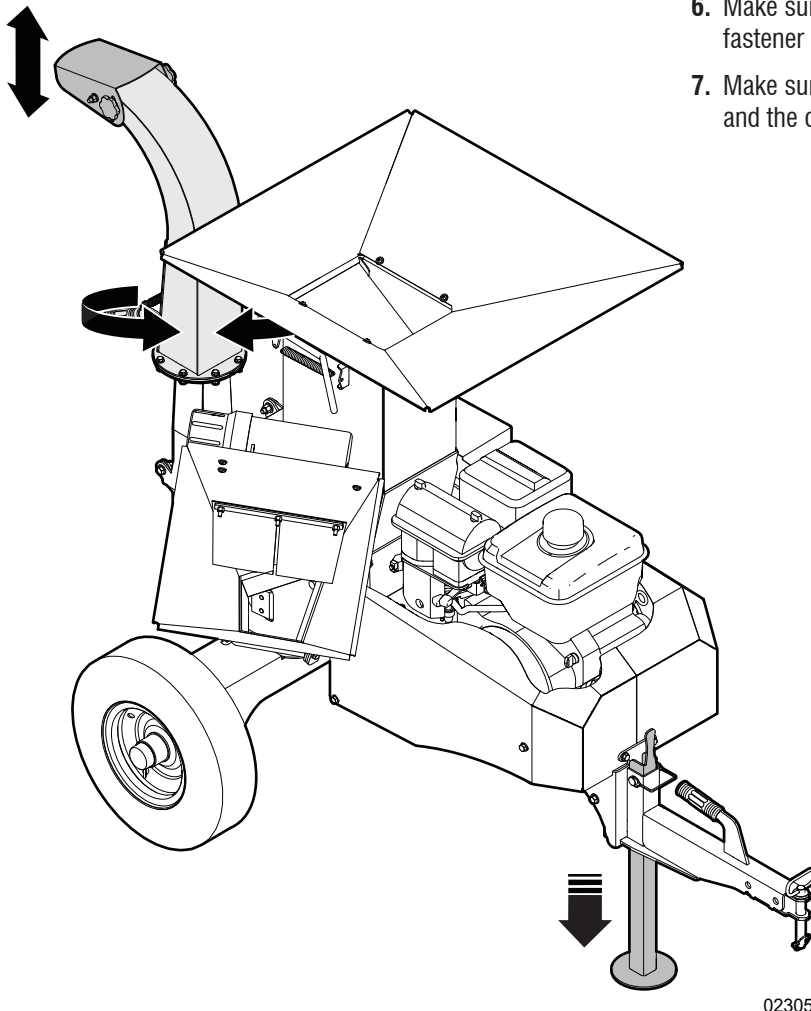

02305

Figure 19—Set up the machine

## 6.9 Operate the Chipper / Shredder

### **! WARNING!**

Wear the personal protective equipment (PPE) that is necessary to do the work safely.

This includes, but is not limited to, a hard hat, hearing protection, a face shield, protective footwear, a respirator, and heavy gloves.

W101

### **! CAUTION!**

Do not operate the machine without the safety curtain installed in the chipper hopper. Replace the safety curtain if it is damaged or missing. The safety curtain prevents wood chips from being blown out of the chipper hopper. The machine can release wood chips fast enough to cause personal injury and property damage.

W119

**IMPORTANT!** Do not put metal objects, bottles, cans, rocks, glass, or other unapproved material into the machine. These items will damage the machine.

If these items get into the machine, set the machine to a safe condition before you remove them. Examine the machine for damage and loose parts.

The operator is responsible to be familiar with and obey all operating and safety procedures.

### 6.9.1 Prepare the Material

- Cut large, curved branches into smaller, straighter sections. Some branches and brush move in unpredictable directions when they enter the rotor housing.
- Hold small diameter branches together in a bundle and put them into the chipper hopper together.
- Put short branches on top of longer branches to avoid reaching into the chipper hopper.
- Put large branches and trees into the chipper hopper one at a time.

### 6.9.2 Chip Wood

### **! WARNING!**

Do not reach into the chipper hopper. There are sharp knives that can trap, cut, and/or sever your fingers or hand. Use a stick or branch to pull material that does not move out of the discharge chute.

If there is a blockage, set the machine to a safe condition, and then remove the material.

W004

Chipper hopper maximum material diameter: 3" (8 cm).

1. Set up the machine.  
For instructions, see *Set Up the Machine* on page 33.
2. Prepare the material.  
For instructions, see *Prepare the Material* on page 34.
3. Start the machine.  
For instructions, see *Start the Machine* on page 32.
4. Make sure that the engine speed is set to **FAST** and the rotor is at full speed (wait three minutes).
5. Slowly, put material (branches and brush) into the chipper hopper until it engages with the rotor.  
The rotor will draw the material into the machine. Do not attempt to force the material into the rotor housing.



Figure 20—Chip wood

### 6.9.3 Shred Material

#### **WARNING!**

Do not reach into the shredder hopper. There are sharp rotating parts that can trap, cut, and/or sever your fingers or hands. Use a stick or branch to push material that does not move into the machine.

If the machine is blocked, set the machine to a safe condition, and then clear the blockage.

#### **CAUTION!**

Do not operate the machine without the shredder gate installed in the shredder hopper. Replace the shredder gate if it is damaged or missing. The shredder gate prevents material from being blown out of the rotor housing. The machine can release material fast enough to cause personal injury and property damage.

#### **CAUTION!**

Only open the shredder gate to let material fall into the machine. Do not use an object to hold the shredder gate open. The machine can release material fast enough to cause personal injury and property damage.

W071

Shredder maximum material diameter: 1" (2.5 cm).

1. Set up the machine.  
For instructions, see *Set Up the Machine* on page 33.
2. Prepare the material.  
For instructions, see *Prepare the Material* on page 34.
3. Start the machine.  
For instructions, see *Start the Machine* on page 32.
4. Make sure that the engine speed is set to **FAST** and the rotor is at full speed (wait three minutes).
5. Put small leafy branches or small diameter wood material into the shredder hopper.  
Do not put too much material into the shredder hopper. Material falls into the machine more easily when the hopper is less full.
6. Use the shredder-gate lever to open the shredder gate.  
For more information, see *Shredder Gate* on page 25.

7. When the shredder hopper is empty, release the shredder-gate lever.  
Monitor the amount of material you put into the machine. If the engine speed starts to decrease, stop putting material into the machine. Wait until the rotor speed increases to continue.
8. As necessary, repeat steps 5 to 7.

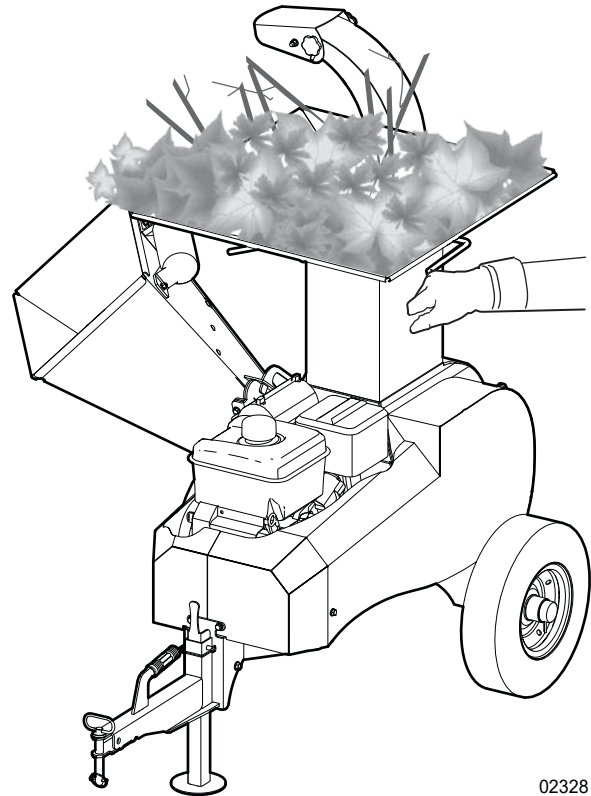

02328

Figure 21 – Shred material

## 6.10 Remove a Blockage

### WARNING!

Put the machine in a safe condition before you remove a blockage. Do not reach into the machine when it is not in a safe condition. When the machine is not in a safe condition, there are crush, sever, and entanglement hazards that can cause serious injury or death.

W120

### CAUTION!

Be careful when you remove a blockage from the lower rotor housing and chop block. The rotor and shredder knives are very sharp.

### CAUTION!

Wear thick work gloves to remove a blockage. Thick work gloves give some protection from sharp objects and splinters.

W121

The machine is designed to handle a wide range of materials. However, if material collects in the machine, follow this procedure to clear the blockage:

1. Set the machine to a safe condition.  
For instructions, see *Safe Condition on page 9*.
2. Remove all of the material from the chipper hopper.
3. Remove all of the material from the shredder hopper.
4. Remove material from the discharge chute and deflector.  
Use a stick to pull material out of the discharge chute. Make sure that the discharge chute and deflector are clear.
5. Start the machine to see if the blockage is cleared.  
If the machine does not operate, remove the blockage from inside the machine.  
For instructions, see *Remove an Internal Blockage on page 36*.

### 6.10.1 Remove an Internal Blockage

1. Set the machine to a safe condition.  
For instructions, see *Safe Condition on page 9*.
2. Remove the upper-rotor-housing fastener, and then open the upper rotor housing. See *Figure 22*.
3. Remove material from the upper rotor housing and discharge chute.
4. Carefully, remove material from the lower rotor housing and chop block.
5. **If necessary**, turn the rotor to remove material from the lower rotor housing. **Do not reach into the rotor housing while the rotor is moving.**
6. Carefully and slowly, turn the rotor in each direction to make sure that there is not a blockage between the rotor and ledger knife.
7. Remove any remaining material and debris from the lower rotor housing.
8. Close the upper rotor housing.
9. Install the upper-rotor-housing fastener. See *Figure 22*.  
Use a calibrated torque wrench to torque the fastener to **33 lbf•ft (45 N•m)**.
10. Start the machine to see if the blockage is cleared.  
If the machine does not operate, do steps 1 to 9 again until the blockage is cleared.

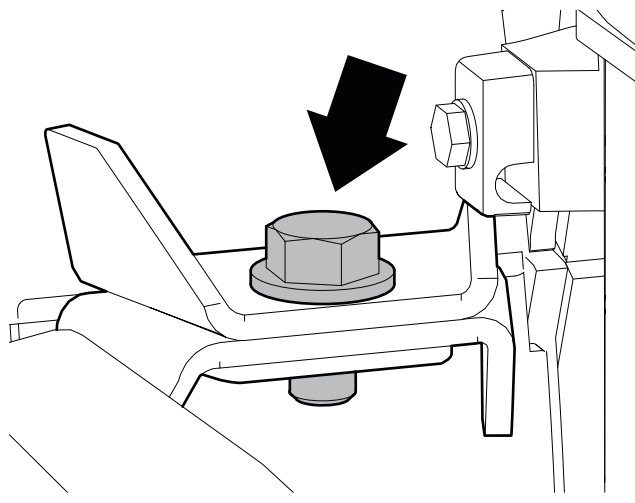
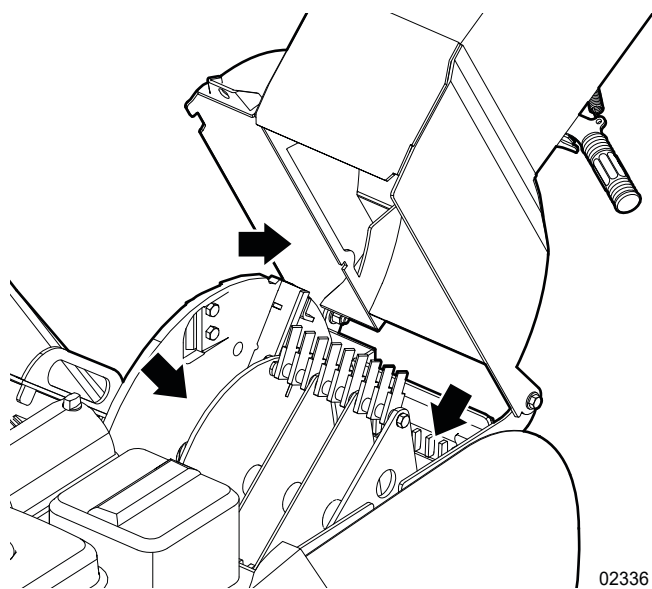

Figure 22—Upper-rotor-housing fastener



**Figure 23** – Open the upper rotor housing

## 7. Transport

**IMPORTANT!** Equipment that is transported on a public roadway must comply with the local laws that govern the safety and transport of machinery.

**This machine is not intended for use or transport on a public roadway. The maximum towing speed is 25 km per hour.**

**This machine does not include the necessary lights, reflectors, and markings. For specific requirements, contact your local transportation authority.**

### 7.1 Transport Safety

- Make sure that the machine is safely attached to the tow vehicle with a retainer through the hitch.
- Do not let people ride on the machine.
- Do not exceed a safe travel speed. Decrease your speed for rough terrain and around corners.
- Plan your route to avoid heavy traffic.
- Do not transport or move the machine with the engine on.
- Make sure that the fuel tank cap is on and tight.
- Examine the wheel rims for damage.
- Examine the tires for cuts or damage.
- Make sure that the tires are filled to the specified pressure. For the correct tire pressure, see the tire sidewall.
- Examine the axle dust caps for leaks and damage. Replace a dust cap that leaks or is damaged.
- Make sure that the jack stand is lifted.
- Make sure that all of the guards and shields are installed and the covers are closed.
- Remove all debris from the machine.
- After the machine is ready for transport, do a circle check to make sure that everything is safe.

### 7.2 Prepare the Machine for Transport

1. Stop the machine.  
For instructions, see *Stop the Machine on page 32*.
2. Remove all material from the chipper hopper.
3. Turn the discharge chute until it is parallel to the shredder hopper to decrease the machine width  
For instructions, see *Discharge Chute on page 24*
4. Make sure that the upper rotor housing is closed, and the fastener is installed and torqued to the correct specification.
5. Attach the machine to a tow vehicle.  
For instructions, see *Connect to a Clevis Hitch on page 40*.

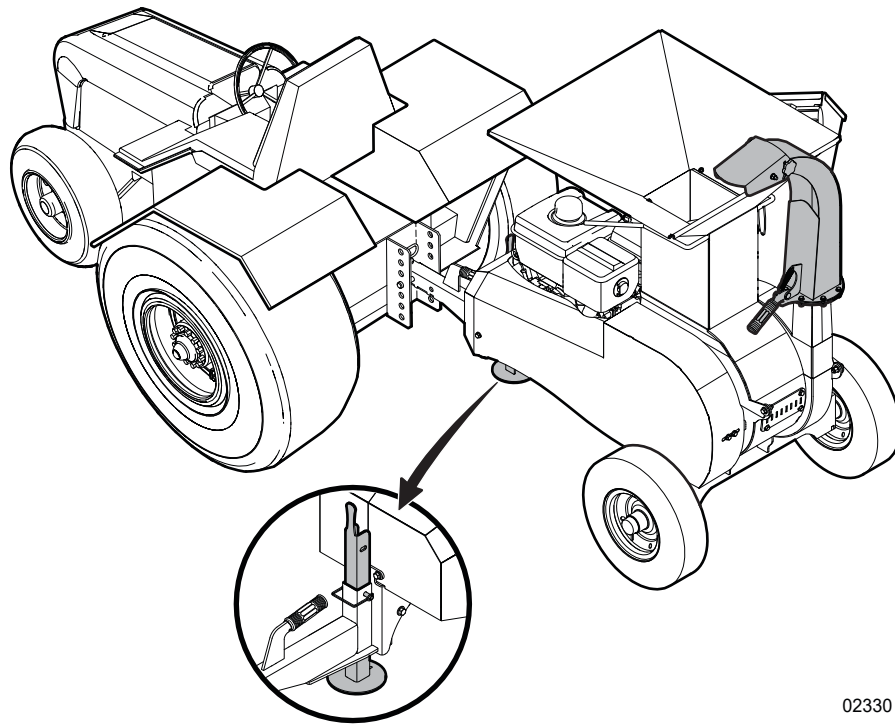

02330

Figure 24 – Transport position

## 7.3 Connect to a Clevis Hitch

Make sure that there is space and clearance to safely reverse the tow vehicle to the machine.

1. Reverse the tow vehicle to the machine. Stop approximately 1 ft (30 cm) away from the hitch.
2. Use the hitch handle to align the hitch with the tow vehicle draw bar.  
For more information, see *Hitch Handle* on page 25.
3. Insert the hitch pin through the hitch and draw bar.
4. Install the snap-lock pin through the hitch pin to make the connection safe.
5. Lift the jack stand.  
For instructions, see *Lift the Jack Stand* on page 41.

## 7.4 Disconnect from a Clevis Hitch

Always park the machine on level, dry ground that is free of debris and other objects before you disconnect the hitch.

Make sure that there is space and clearance to safely drive the tow vehicle forward, away from the machine.

1. Stop the tow vehicle in a location where it and the machine are on dry, level ground. Stop the engine and apply the parking brake.
2. Lower the jack stand.  
For instructions, see *Lower the Jack Stand* on page 40.
3. Remove the snap-lock pin from the hitch pin.
4. Remove the hitch pin from the hitch and draw bar.
5. Use the hitch handle to move the machine away from the tow vehicle draw bar.
6. Install the hitch pin through hitch, and then install the snap-lock pin through the hitch pin.
7. Slowly, drive the tow vehicle forward away from the machine.
8. Stop the tow vehicle and apply the parking brake.

## 7.5 Jack Stand

### CAUTION!

**Do not pull the pin out of a jack stand when there is weight on the jack. The machine can move unexpectedly and cause minor to severe injuries. Attach the machine to a tow vehicle or put blocks under the hitch to hold the weight before you remove the pin from a jack stand.**

The jack stand has two functions. It supports the machine when it is not attached to a tow vehicle or helps to keep the machine stable when it is attached to a tow vehicle.

### 7.5.1 Lower the Jack Stand

1. Remove the snap-lock pin from the hitch frame and jack stand.
2. Lower the jack stand.  
Align the top hole in the jack stand with the hole in the hitch frame.
3. Insert the snap-lock pin through the hitch frame and jack stand.

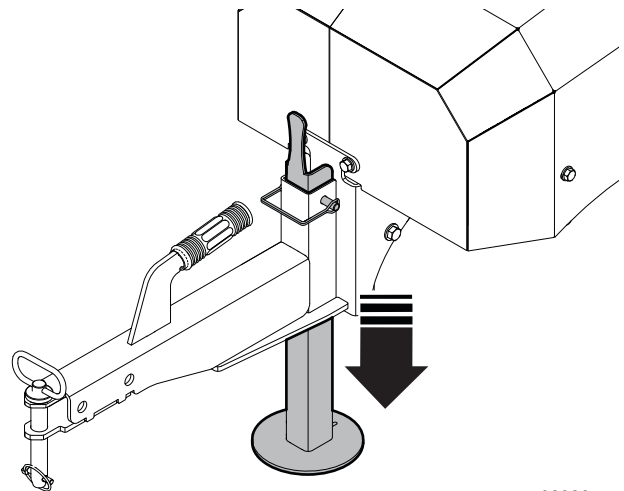

02326

Figure 25—Jack stand in the lowered position



## 7.5.2 Lift the Jack Stand

1. Support the machine to remove weight from the jack stand.  
Attach the machine to a tow vehicle or support the front of the machine with blocks.
2. Remove the snap-lock pin from the hitch frame and jack stand.
3. Lift the jack stand.  
Align the bottom hole in the jack stand with the hole in the hitch frame.
4. Insert the snap-lock pin through the hitch frame and jack stand.

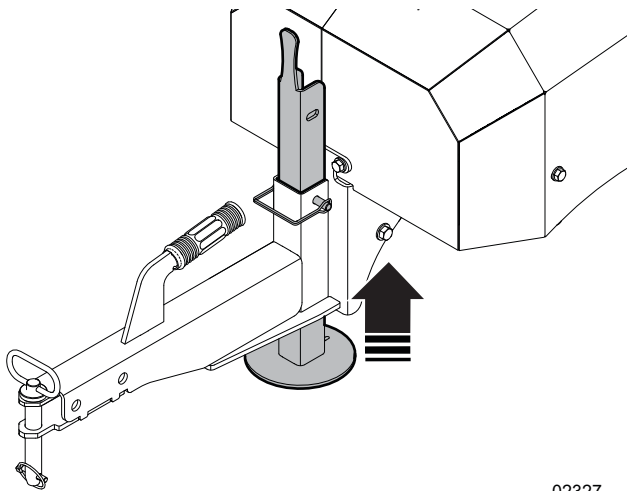

02327

**Figure 26**– Jack stand in the lifted position

## 8. Storage

At the end of the season or when the machine is not going to be used for an extended length of time, store the machine correctly to prevent damage.

For reference, see *Figure 27 on page 44*.

### 8.1 Storage Safety

#### **WARNING!**

**Do not let children play on or around the stored machine. If children play on or around the machine it can result in serious injury or death.**

W105

#### **CAUTION!**

**Store the machine away from furnaces, stoves, water heaters, or other appliances that have a pilot light or other ignition source. A pilot light or other source of ignition can ignite fuel vapors.**

W123

**IMPORTANT! A pressure washer can damage the machine's product identification plate and make it unreadable. Do not direct the spray from a pressure washer onto the product identification plate. Use a clean, soft cloth that is dampened with water to remove dirt.**

- Store the machine in a dry, level location away from human activity.
- Store the machine indoors, if possible.
- If necessary, support the machine with blocks for stability.

### 8.2 Put the Machine in Storage

For information about engine storage, see the engine manufacturer's manual.

1. Set the machine to a safe condition.  
For instructions, see *Safe Condition on page 9*.
2. Check all of the moving parts and remove all entangled material.
3. Clean the machine.  
For instructions, see *Clean the Machine on page 63*
4. Start the machine, let it run for a few minutes to remove any moisture, and then stop the machine.
5. Do step 1 again.

6. Examine the machine fully, including internal components. Replace or repair any worn or damaged components.

7. Paint scratches and dents to prevent rust.

8. Do one of the following:

- If the machine will be in storage for one to three months, add stabilizer to the engine fuel, and then operate the engine for a minimum of three minutes to move the stabilizer through the engine.

- If the machine will be in storage for longer than three months, replace the engine fuel with an alkylate or appropriate engineered fuel. These fuel types prevent the buildup of deposits in the engine.

For more information, see *Engine Fuel on page 46*.

For instructions, see *Replace the Engine Fuel on page 43*.

9. Park the machine in the storage location.

10. Disconnect the tow vehicle.

For instructions, see *Disconnect from a Clevis Hitch on page 40*.

11. Adjust the trailer jack to make the machine as level as possible.

If the machine must be on soft ground, put boards or plates under the trailer jack to increase the surface area.

12. Block the machine wheels to prevent accidental movement and increase the wheel bearing life.

13. Remove the battery.

Store the battery in a cool, dry place, where it cannot freeze. Connect a battery maintainer to keep it at full charge. See *Figure 27 on page 44*.

For instructions, see *Remove the Battery on page 52*.

14. If the machine must be stored outdoors, cover the machine with a waterproof tarp.

The machine should be stored indoors, if possible.

### 8.3 Remove the Machine from Storage

1. Install the battery.

For instructions, see *Install the Battery on page 52*.

2. Do the *Pre-Start Checklist on page 27*.

3. Do the necessary maintenance.

For necessary maintenance, see the *Maintenance Schedule on page 47*.

## 8.4 Replace the Engine Fuel

### **WARNING!**



Do not smoke or vape when you handle fuel. Fuel vapours can explode causing serious injury or death. Keep sparks, flames, or hot components away from fuel.

W027

### **WARNING!**

Fuel and vapors are very flammable and explosive. Fire or explosion can cause severe burns, bodily harm, or death. Keep fuel away from sparks, open flame, pilot lights, heat, and any other source of ignition.

W116

### **CAUTION!**

Fuel vapors are very toxic. Breathing fuel vapors can cause irritation, illness, or unconsciousness. Check the fuel level or add fuel to the engine outdoors or in an area that has good air flow.

W117

1. Stop the machine.  
For instructions, see *Stop the Machine on page 32*.
2. Wait for the engine and fluids to cool.
3. Remove the current fuel from the engine.  
Operate the machine until the fuel tank is empty or drain the fuel tank and properly dispose of the fuel.
4. Add new fuel to the engine.  
For instructions, see *Add Fuel to the Engine on page 30*.
5. Carefully remove any spilled fuel, and then wait until any remaining fuel dries.
6. Tighten the fuel cap.
7. Start the machine.  
For instructions, see *Start the Machine on page 32*.
8. Wait five to 10 minutes for the fuel to go through the engine.
9. Stop the machine.  
For instructions, see *Stop the Machine on page 32*.

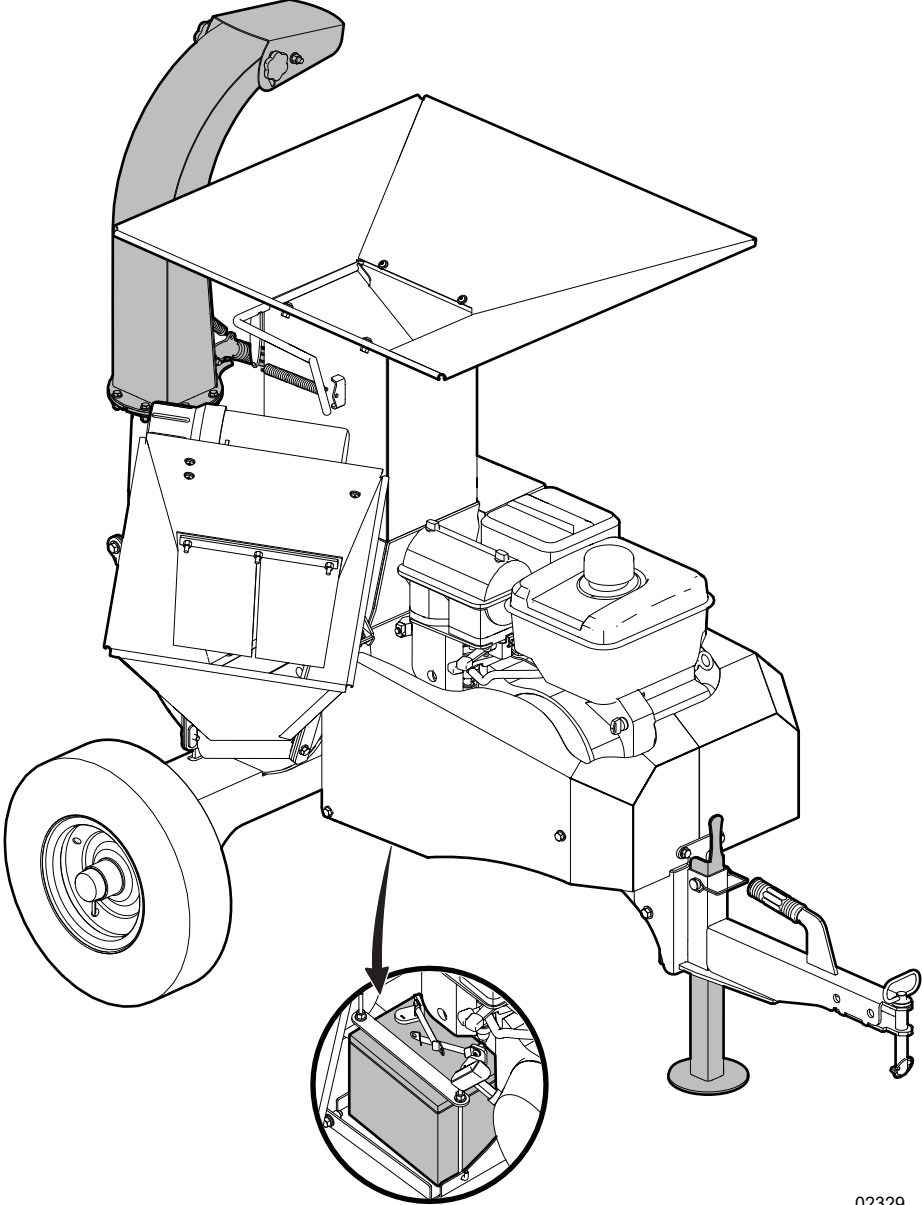

02329

Figure 27 – Storage position

## 9. Service and Maintenance

Regular preventive maintenance can improve performance and prolong the life of the machine. Machine maintenance is your responsibility.

### 9.1 Service and Maintenance Safety

#### **WARNING!**

**Before you start service or maintenance work:**

- **Set the machine to a safe condition.**
- **Wait for the machine to cool down. Engine components and fluids may be hot enough to cause burns.**
- **Read and understand all of the service and maintenance safety information.**

W041

#### **WARNING!**

**Wear the personal protective equipment (PPE) that is necessary to do the work safely.**

**This includes, but is not limited to, a hard hat, hearing protection, a face shield, protective footwear, a respirator, and heavy gloves.**

W101

#### **WARNING!**

**After service and maintenance, install all of the guards and shields, and close all of the covers. Do not operate the machine with any guard or shield removed, or cover open.**

W110

**Set the machine to a safe condition before you start any service or maintenance:**

#### **SAFE CONDITION**

1. If the machine is connected to a tow vehicle, set the tow vehicle's parking brake, stop the engine, and remove the ignition key.
2. Stop the machine.  
For instructions, see *Stop the Machine on page 32*.
3. Disconnect the engine spark-plug wire and keep it away from the spark plug.
4. Remove all material from the chipper hopper and shredder hopper.
5. Wait until the engine and machine are cool.

- Follow good shop practices:
  - Keep the work area clean and dry.
  - Ground electrical outlets and tools.
  - Have sufficient light for good visibility.
- Use tools that are in working condition and correct for the task. Make sure that you know how to use the tools before you use them.
- Only operate the engine in a location that has good air flow. Engine exhaust gases contain carbon monoxide (an odorless gas) that can cause asphyxiation.
- Do not work under equipment unless it is safely supported with blocks.
- Do not do service or maintenance work alone. Always have a minimum of two people in case an emergency situation occurs.
- Keep a fire extinguisher and first aid kit available at all times.
- When service or maintenance is complete, do the following:
  - Replace all guards and shields, and close the covers.
  - Torque the fasteners to the correct specifications.
  - Make sure that all the electrical, hydraulic, and fuel connections are connected in a safe working condition.
- Do not use gasoline or diesel fuel to clean parts. Use the correct cleaning product.
- When replacement parts are necessary, use genuine factory replacement parts to restore your machine to the original specifications. The manufacturer cannot be responsible for injuries or damages caused by use of unapproved parts and/or accessories.

## 9.2 Fluids and Lubricants

The machine needs the correct fluids and lubricants for operation and maintenance.

### 9.2.1 Lubricant Handling and Storage

For optimum machine efficiency, use clean lubricants and clean containers to handle all lubricants. Store lubricants in an area that is protected from dust, moisture, and other contaminants.

### 9.2.2 Engine Oil

**For engine maintenance and service information, see the engine manufacturer's manual.**

Briggs & Stratton® Warranty Certified oils are recommended for the best engine performance. However, other high-quality detergent oils are permitted if they are classified for service SF, SG, SH, SJ, or higher. Do not use special additives.

Outdoor temperatures determine the necessary engine oil viscosity. Select the best oil viscosity for the expected outdoor temperature range. Use the following chart as a guide:

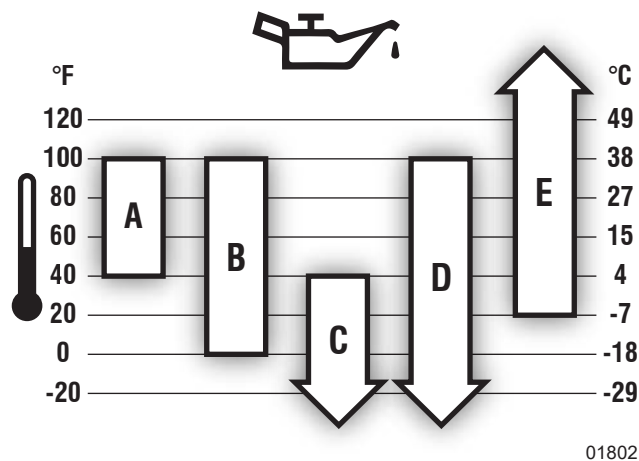

- |          |                                                                                                                            |
|----------|----------------------------------------------------------------------------------------------------------------------------|
| <b>A</b> | <b>SAE 30</b> – Below 40 °F (4 °C) the use of SAE 30 results in hard starting.                                             |
| <b>B</b> | <b>10W-30</b> – Above 80 °F (27 °C) the use of 10W-30 may cause increased oil consumption. Check the oil level frequently. |
| <b>C</b> | <b>5W-30</b>                                                                                                               |
| <b>D</b> | <b>Synthetic 5W-30</b>                                                                                                     |
| <b>E</b> | <b>Vanguard® Synthetic 15W-50</b>                                                                                          |

### 9.2.3 Engine Fuel

**For complete fuel information and use at high altitudes, see the engine manufacturer's manual.**

Fuel must meet the following specifications:

- Clean, fresh, unleaded gasoline.
- Minimum of 87 octane / 87 AKI (91 RON).
- Gasoline with up to 10% ethanol (gasohol) is acceptable if the fuel is fresh (less than three months old).

If the machine will be in storage for longer than three months, replace the fuel with one of the following fuel types:

- An alkylate fuel
- An engineered fuel that is high octane, ethanol-free, and formulated with power detergent to prevent the buildup of insoluble solids (deposits).

For instructions, see *Replace the Engine Fuel* on page 43.

### 9.2.4 Grease

Use an SAE multi-purpose high temperature grease with extreme pressure (EP) performance. An SAE multipurpose lithium-based grease is an acceptable substitute.

### 9.2.5 Rust Protection Lubricant

Use a good quality rust protection oil and lubricant that is intended for use on metal.

### 9.3 Maintenance Schedule

Complete maintenance tasks at the specified time or hour interval, whichever comes first.

**IMPORTANT!** For more information, see the engine manufacturer's manual.

Task	8 hours or daily	50 hours or annually	100 hours or annually	200 hours or annually	Annually	600 hours or every three years	Reference
Check the engine oil level and quality.	●						See page 31.
Check the engine fuel level.	●						See page 30.
Clean the engine around the muffler and controls.	●						N/A <sup>1</sup> .
Check that all the fasteners are torqued to the correct specifications.	●						See page 67.
Remove all debris and entangled material.	●						N/A.
Check the drive belt operation.	●						See page 54.
Clean the engine air-intake grille.	●						N/A.
Check the rotor knife, ledger knife, shredder knife, and twig breaker sharpness.		●					See page 58.
Check the battery condition.		●					See page 52.
Lubricate pivot points and hinges.		●					See page 50.
Grease the machine.		●					See page 49
Check the drive belt tension and alignment.		●					See page 54.
Check the chop block condition and sharpness.		●					See page 61
Check the tire pressure.			●				See the tire sidewall.
Clean the machine.			●				See page 63.
Service the engine exhaust system.			●				See the engine manual.
Clean the engine air filter. <sup>2</sup>				●			See page 51.
Change the engine oil and replace the oil filter.				●			See the engine manual.
Check the valve clearance.					●		See the engine manual.
Replace the engine spark plug.					●		See the engine manual.
Service the fuel system.					●		See the engine manual.
Service the engine cooling system. <sup>2</sup>					●		See the engine manual.
Replace the engine air filter. <sup>3</sup>						●	See the engine manual.

1 N/A indicates that a reference is not applicable.  
 2 In dusty conditions or when airborne debris is present, clean more often.  
 3 Every third air filter change, replace the air safety filter.

## 9.4 Grease Points

**IMPORTANT!** Do not over grease a bearing. Too much grease can cause the bearing seals to fail.



Look for this type of label on the machine. Each label identifies a grease point and shows the greasing interval in hours.

For grease specifications, see *Grease on page 46*.

- Use a clean cloth to clean each grease fitting before you apply grease. This prevents grease and dirt from getting inside the component.
- Use a hand-held grease gun to apply **one pump** of grease to each grease point.
- If a grease fitting is damaged, replace it immediately.
- If a grease fitting does not accept grease:
  - a. Remove the grease fitting.
  - b. Clean the passageway behind the grease fitting.
  - c. Clean the grease fitting thoroughly or get a new grease fitting.
  - d. Install the grease fitting.



### 9.4.1 Grease Fitting Locations

Item	Location	Frequency	Number of Locations
1	Rotor-shaft bearings	50 hours or annually	2

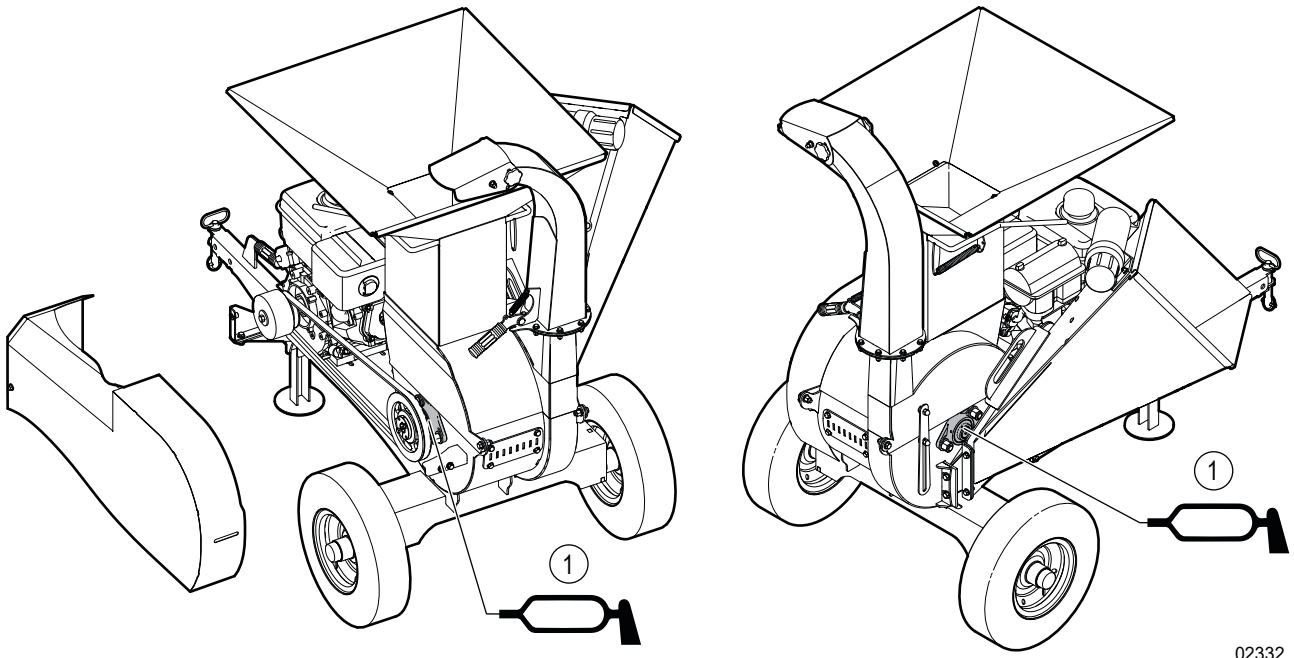

Figure 28 – Grease fitting locations

### 9.4.2 Hinge and Pivot Point Locations

Hinge and pivot points can rust and become difficult to move without the correct maintenance. Apply a small amount of rust-prevention oil to the following locations:

Item	Location	Frequency	Number of Locations
1	Deflector	50 hours or annually	2
2	Jack stand	50 hours or annually	1
3	Discharge chute	50 hours or annually	1

For more information, see 9.2.5 *Rust Protection Lubricant* on page 46.

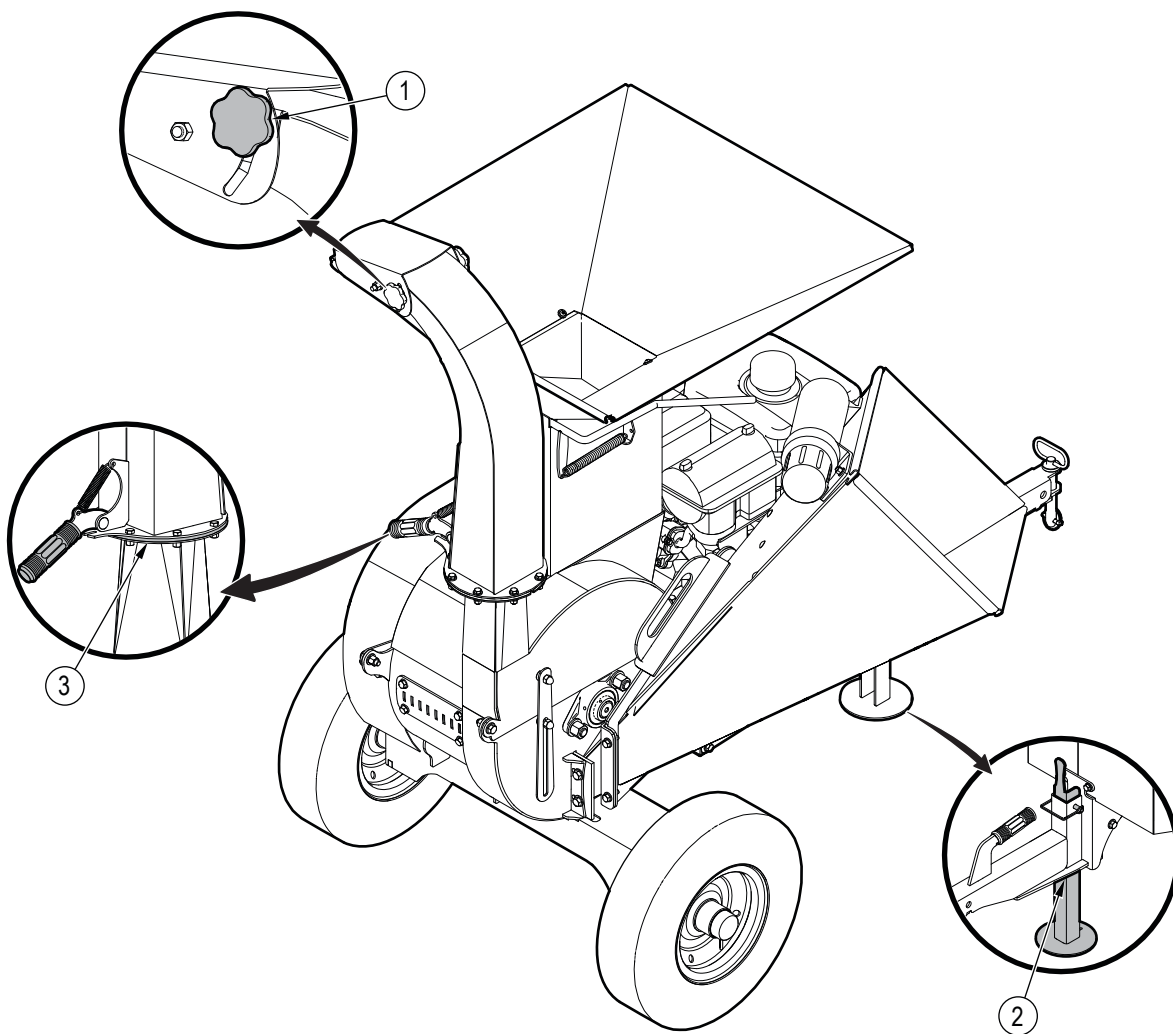

02333

Figure 29—Hinge and pivot point grease locations

## 9.5 Engine Maintenance

For full engine maintenance information, see the engine manufacturer's manual.

### 9.5.1 Engine Maintenance Safety

#### **! WARNING!**

**Do not operate the engine indoors. Park the machine outdoors in a position where the prevailing winds blow the exhaust away from you.**

**Engine exhaust contains carbon monoxide (CO) that can quickly accumulate to a dangerous level. Carbon monoxide can cause illness, unconsciousness, or death.**

W072

#### **! WARNING!**

**Keep the end of a disconnected battery cable away from the battery. Electricity can arc from the battery to the end of a battery cable and cause the battery to explode. An explosion can cause serious injury or death from heat, impact, and chemical hazards.**

W115

For more information, see *Engine Operation Safety* on page 28.

- Remove the wire from the spark plug before servicing the engine or equipment to prevent the engine from starting.
- Examine the muffler on a regular basis to make sure that it operates effectively. Repair or replace a muffler that is worn or leaks.
- Before storage, replace fuel that contains ethanol with an alkylate or appropriate engineered fuel to prevent the buildup of deposits.
- Check the fuel lines and fittings frequently for cracks or leaks. Replace fuel lines or fittings that are damaged.
- Store fuel away from all wood material.
- Do not check for a spark with the spark plug or spark plug wire removed.
- Do not hit the flywheel with a hard object or metal tool. This can cause the flywheel to shatter during operation. Use the correct tools to service the engine.
- Do not touch a hot muffler, cylinder, or fins. Contact can cause burns.

### 9.5.2 Clean the Engine Air Filter

**IMPORTANT! Operating the engine without an air filter, or with a damaged air filter, can let dirt to enter the engine, causing rapid engine wear. This type of damage is not covered by the warranty.**

**Clean the air filter every 200 hours of operation or annually.**

A dirty air filter can restrict air flow to the carburetor, reducing the engine performance. If the engine is operated in very dusty areas, clean the air filter more often than specified.

1. Loosen the two air-filter cover fasteners.
2. Remove the cover.
3. Remove the air filter.
4. Gently tap the air filter on a hard surface to loosen and remove dust and debris.
5. If the air filter is excessively dirty or damaged, replace it with a new air filter.
6. Install the air filter in the engine.
7. Install the cover.
8. Tighten the two air-filter cover fasteners.

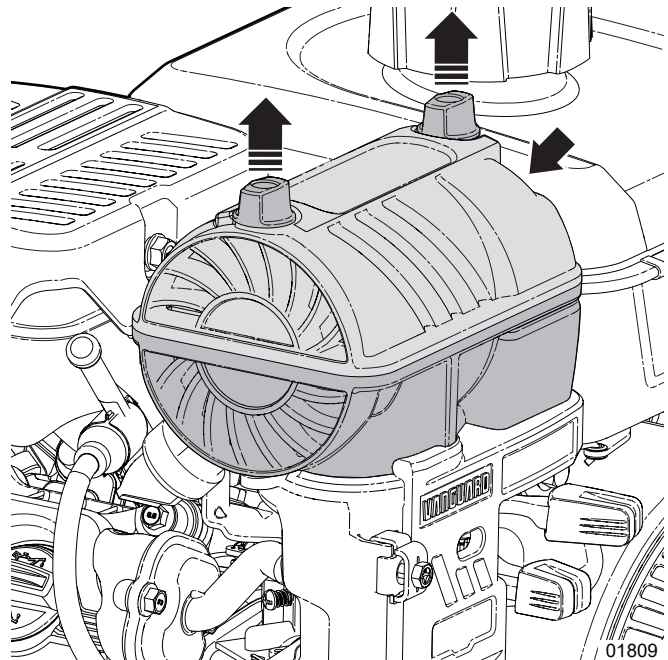

**Figure 30**—Engine air filter

## 9.6 Battery Maintenance

The battery provides power to the electrical components on the machine and the engine.

### 9.6.1 Battery Safety

#### **WARNING!**

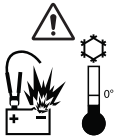

Warm the battery to a minimum of 60 °F (16 °C) before charging it. Attempting to charge a frozen battery can cause it to explode. An explosion can cause serious injury or death from projectiles, extreme heat, chemicals, and loud noise.

W030

#### **CAUTION!**

Wash your hands thoroughly after handling a battery. Avoid contact with the battery posts, terminals, and related accessories. They contain lead and lead compounds that are known to cause cancer and birth defects or other reproductive harm.

W031

#### **WARNING!**

Wear the necessary PPE and handle batteries carefully. The electrolyte in the battery is poisonous and very corrosive. If electrolyte touches skin, eyes, or clothing it can cause severe burns or other personal injury. If you touch battery electrolyte, get immediate medical attention.

W020

#### **WARNING!**

Do not let metal objects touch the battery terminals. Cover the battery terminals when servicing the battery or the drive belt guard is removed. Electricity can arc from the battery terminal to the metal object and cause a fire or explosion. An explosion can cause serious injury or death from heat, impact, and chemical hazards.

W021

#### **WARNING!**

Keep the end of a disconnected battery cable away from the battery. Electricity can arc from the battery to the end of a battery cable and cause the battery to explode. An explosion can cause serious injury or death from heat, impact, and chemical hazards.

W115

- Keep all sparks and flames away from batteries. Electrolyte fumes are explosive.
- Do not jump start a frozen battery. The battery can explode.
- Wear the appropriate gloves and protective eye wear, or a face shield when you work with or near batteries.
- Use a battery carrier to lift the battery or put your hands on opposite corners of the battery. Keep the battery level to avoid spilling acid through the vents.
- Avoid contact with battery electrolyte:
  - **External contact:** flush immediately with water.
  - **Eye contact:** flush with water for 15 minutes. Get medical attention and clean any spilled electrolyte immediately.
- Disconnect the battery ground cable before servicing any part of the electrical system. A spark or short circuit can cause personal injury.

### 9.6.2 Remove the Battery

1. Disconnect the battery cable from the negative (–) battery terminal.
2. Disconnect the battery cable from the positive (+) battery terminal.
3. Remove the battery hold-down bracket.
4. Remove the battery from the machine.  
Use a battery carrier to lift the battery or put your hands on opposite corners of the battery. Keep the battery level to avoid spilling battery acid through the vents.

### 9.6.3 Install the Battery

1. Put the battery in the machine.
2. Install the battery hold-down bracket.  
Make sure that the battery cannot move.
3. Connect the positive (+) battery cable (usually red) to the positive (+) battery terminal.
4. Connect the then negative (–) battery cable (usually black) to the negative (–) battery terminal.
5. Apply a coat of dielectric grease or petroleum jelly to each battery terminal.

## 9.6.4 Clean the Battery

When the battery cable ends are not connected to the battery terminals, keep them away from the battery.

1. Disconnect the battery cable from the negative (-) battery terminal.
2. Disconnect the battery cable from the positive (+) battery terminal.
3. Apply a coat of baking soda to the battery terminals and battery-cable ends.
4. Pour a small amount of water over the baking soda.
5. Use a wire brush to clean the battery cable ends and the terminals.
6. Rinse the battery cable ends and terminals with clean water.
7. Wait until all of the water evaporates or use compressed air to remove the water. Make sure that the battery cable ends and terminals are fully dry before connecting them.
8. Connect the positive (+) battery cable (usually red) to the positive (+) battery terminal.
9. Connect the negative (-) battery cable (usually black) to the negative (-) battery terminal.
10. Apply a coat of dielectric grease or petroleum jelly to each battery terminal.

## 9.6.5 Charge the Battery

**IMPORTANT! Do not fast charge the battery. Use a battery charger that is between 4 A and 7.5 A. Do not use a charger that is higher than 10 A.**

Always read and obey the information that is provided with the battery and the battery charger. For more information and instructions, contact the battery manufacturer and battery charger manufacturer.

1. Remove the battery from the machine.  
For instructions, see *Remove the Battery on page 52*.
2. Use a battery carrier to lift the battery or put your hands on opposite corners of the battery.  
Keep the battery level to avoid spilling battery acid through the vents.
3. Put the battery in a dry, cool place that is away from activity and has good air flow.
4. Use a battery charger to charge the battery.  
For instructions, see the battery charger manufacturer information.

## 9.7 Tire Maintenance and Safety



**Take the machine to a qualified dealer or distributor to have a tire mounted on a wheel or rim. Do not mount a tire on a wheel or rim without the correct equipment and experience. Incorrectly mounting a tire can cause an explosion that can result in serious injury or death.**

W124

**IMPORTANT! Replace worn tires with tires that meet the original tire specifications. Do not undersize tires.**

- Check the tire pressure before towing the machine on a roadway. See the tire sidewall for the correct pressure.
- At a minimum, check the tire pressure every 100 hours of operation or annually.

## 9.8 Drive Belt Maintenance

### WARNING!

Wait for hot machine components to cool before you work on the machine. Hot machine components can cause serious burns or start a fire. Do not touch hot machine components. Use a no-touch thermometer to measure the temperature.

W109

### WARNING!

Do not operate the machine with any of the guards or shields removed. The machine is shown with guards or shields removed for illustrative purposes only.

W001

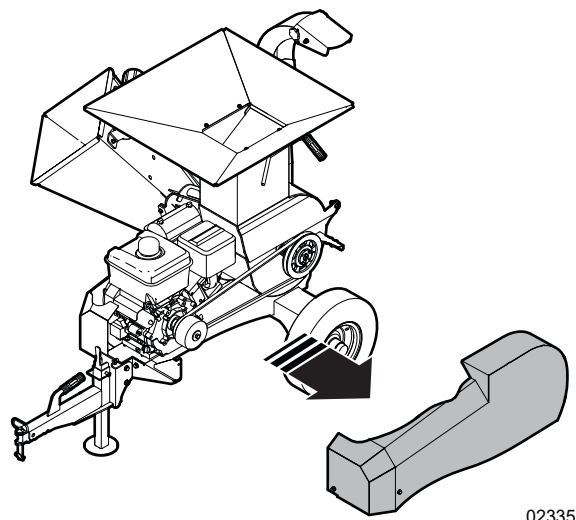
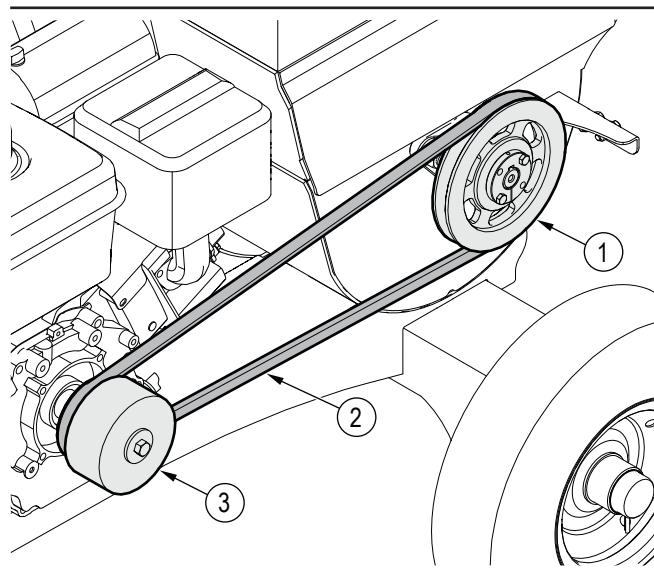

**Figure 31**—Remove the drive-belt guard

### 9.8.1 Replace the Drive Belt

**IMPORTANT!** After the rotor drive belt is replaced, set the belt tension and make sure that the alignment is correct.

1. Remove the drive-belt guard fasteners and the guard.
2. Loosen (do not remove) the four bolts that attach the engine mount to the machine frame. See *Figure 35 on page 55*.
3. Turn the drive-belt tensioning bolt to move the engine and remove tension from the drive belt. See *Figure 34 on page 55*.
4. Remove the drive belt.
5. Install a new drive belt on the rotor sheave and the clutch flywheel.
6. Align the drive belt.  
For instructions, see *Align the Drive Belt on page 56*.
7. Set the drive belt tension.  
For instructions, see *Set the Drive Belt Tension on page 55*.
8. Install the drive-belt guard and the fasteners.
9. Use a calibrated torque wrench to torque the fasteners to **19 lbf•ft (25 N•m)**.



**Figure 32**—Drive belt

1. Rotor sheave
2. Drive belt
3. Engine clutch flywheel

## 9.8.2 Set the Drive Belt Tension



A drive-belt tension gauge, ruler, or tape measure is necessary for this procedure. A drive-belt tension gauge is the most accurate tool.

**Check the drive belt tension after every 100 hours of operation.**

1. Press on the top centre of the rotor drive belt and measure the distance it moves. See *Figure 33*.
2. Do one of the following:
  - If the drive belt movement measures **between 1/4" (6 mm) and 3/8" (10 mm)**, the drive belt tension is correct. You do not need to set the drive belt tension.
  - If the drive belt tension is not correct, continue with the following steps to set the drive belt tension.
3. Loosen (do not remove) the four bolts that attach the engine mount to the machine frame. See *Figure 35*.
4. Use the drive-belt tensioning bolt to set the drive belt tension. See *Figure 34*
5. Do steps 1, 2, and 4 again, until the drive belt tension is correct.
6. Tighten the four engine mount bolts.
7. Do step 1 again.
8. Do one of the following:
  - If the belt tension is correct, continue with step 9.
  - If the belt tension is not correct, do steps 3 to 7 again.
9. Align the drive belt.  
For instructions, see *Align the Drive Belt on page 56*.
10. Use a calibrated torque wrench to torque the four engine mount bolts to **33 lbf•ft (45 N•m)**.
11. Check the drive belt tension again after 10 hours of operation.

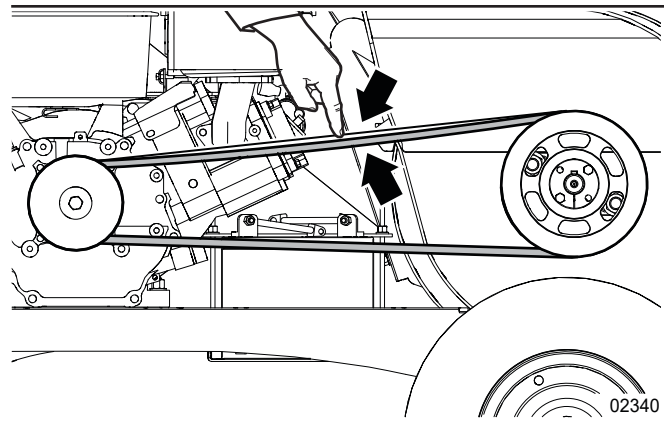

**Figure 33**—Check the drive belt tension

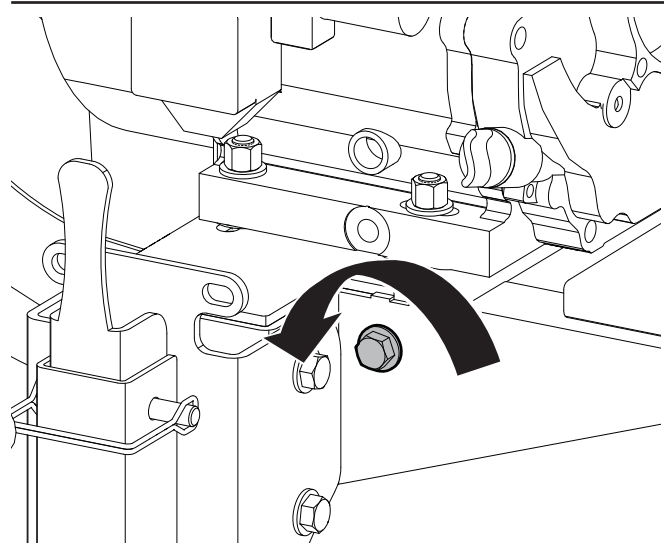

**Figure 34**—Drive belt tensioning bolt

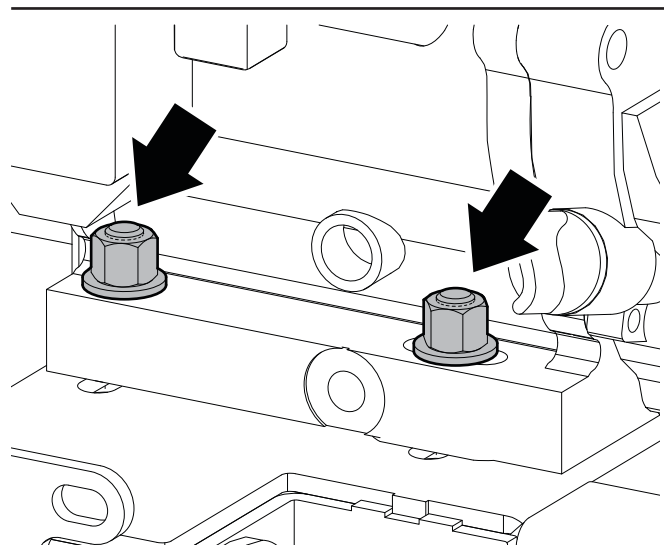

**Figure 35**—Engine mount bolts (two of four)

### 9.8.3 Align the Drive Belt



A straight-edge tool that is a minimum of 50" (127 cm) long is necessary for this procedure.

Check the drive belt alignment after every 8 hours of operation.

The maximum misalignment is 1/32" (1 mm).

- Put a straight-edge tool across the face of the rotor sheave. Point the opposite end of the straight-edge toward the engine clutch flywheel. Make sure that the straight-edge is parallel with the face of the rotor sheave. See *Figure 36*.
- Do one of the following:
  - If the edge of the engine clutch flywheel aligns with the straight-edge, the drive belt is aligned. The following steps are not necessary. See *Figure 36*.
  - If the edge of the engine clutch flywheel is parallel to the straight-edge tool, but is not aligned with the rotor sheave, align the rotor sheave. See *Figure 39 on page 57*. For instructions, see *Align the Rotor Sheave on page 57*.
  - If the edge of the engine clutch flywheel is not parallel (is on an angle) to the straight-edge tool, align the engine clutch. See *Figure 37*. For instructions, see *Align the Engine Clutch*.
- Do steps 1 and 2 again to make sure the drive belt is aligned.

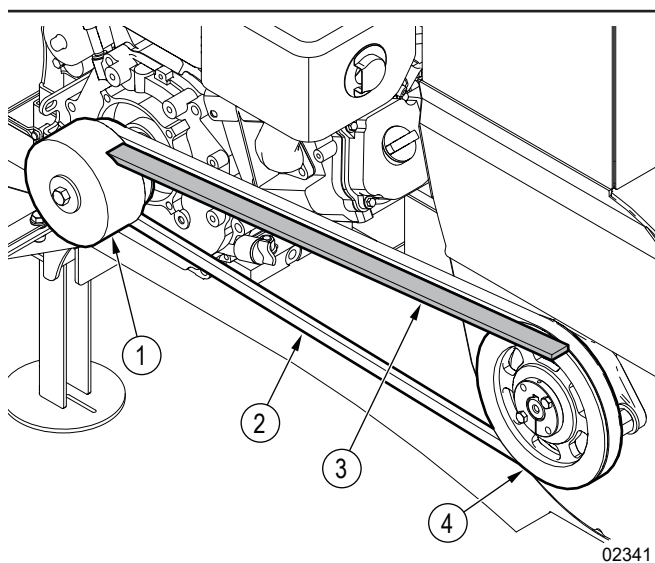

**Figure 36**—Check the drive belt alignment

- |                           |                  |
|---------------------------|------------------|
| 1. Engine clutch flywheel | 3. Straight edge |
| 2. Drive belt             | 4. Rotor sheave  |

### 9.8.4 Align the Engine Clutch

The engine mount can move and cause drive-belt misalignment.

- Loosen (do not remove) the four engine mount bolts. See *Figure 35*.
- Turn the engine a small amount to adjust the clutch and align the belt.
- Check the drive belt alignment. For instructions, see *Align the Drive Belt on page 56*.
- Do one of the following:
  - If the belt alignment is correct, continue with step 5.
  - If the belt alignment is not correct, do steps 2 to 4 again.
- Tighten the four engine mount bolts.
- Do steps 3 and 4 again.
- Do one of the following:
  - If the belt alignment is correct, continue with step 8.
  - If the belt alignment is not correct, do steps 1 to 4 again.
- Use a calibrated torque wrench to torque the four engine mount bolts to **33 lbf • ft (45 N • m)**.
- Check the drive belt tension. For instructions, see *Set the Drive Belt Tension on page 55*.

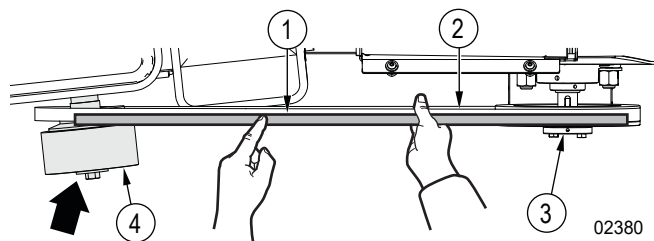

**Figure 37**—Align the engine clutch

- |                  |                           |
|------------------|---------------------------|
| 1. Straight edge | 3. Rotor sheave           |
| 2. Drive belt    | 4. Engine clutch flywheel |



## 9.8.5 Align the Rotor Sheave

The rotor sheave can become loose on the shaft and cause drive-belt misalignment.

The numbers in brackets refer to *Figure 38*.

1. Remove the set screw (2) from the sheave (1).  
Put the set screw aside. It is necessary for assembly.
2. Remove the sheave bolts (5).
3. Thread the sheave bolts into the puller holes (6) on the sheave hub (3).
4. In an even pattern, turn each of the bolts clockwise in 1/4 turn increments.
5. Do step 4 until there is space between the sheave hub and the sheave, and they can move on the shaft.
6. Lightly tap the sheave hub with a small rubber mallet to move it on the shaft and align the drive belt.
7. Check the drive belt alignment.  
For instructions, see *Align the Drive Belt on page 56*.
8. Do one of the following:
  - If the belt alignment is correct, continue with step 9.
  - If the belt alignment is not correct, do steps 6 to 8.
9. Remove the sheave bolts from the puller holes.  
Turn them counterclockwise in 1/4 turn increments.
10. Install the sheave bolts in the sheave hub.
11. Do step 4 until the sheave bolts are tight.
12. Install and then tighten the set screw (2).
13. Do step 6 again.
14. Do one of the following:
  - If the belt alignment is correct, continue with step 15.
  - If the belt alignment is not correct, do steps 1 to 14.
15. Use a calibrated torque wrench to torque the three sheave bolts to **9 lbf•ft (12 N•m)**.
16. Check the drive belt tension.  
For instructions, see *Set the Drive Belt Tension on page 55*.

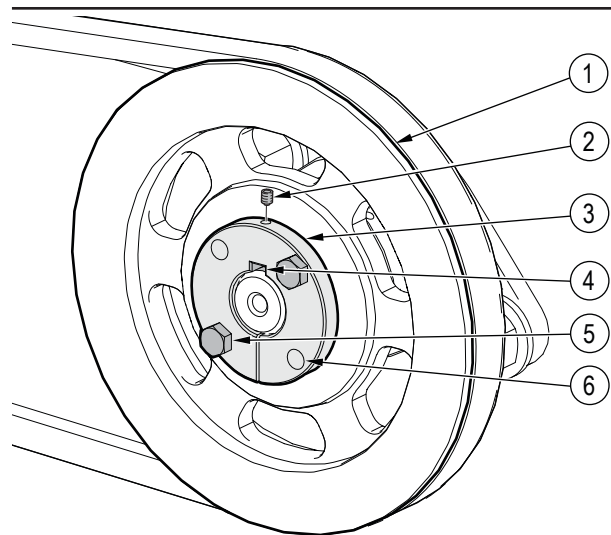

02342

**Figure 38**—Rotor sheave

- |               |                         |
|---------------|-------------------------|
| 1. Sheave     | 4. Shaft key            |
| 2. Set screw  | 5. Sheave bolt (1 of 2) |
| 3. Sheave hub | 6. Puller hole (1 of 2) |

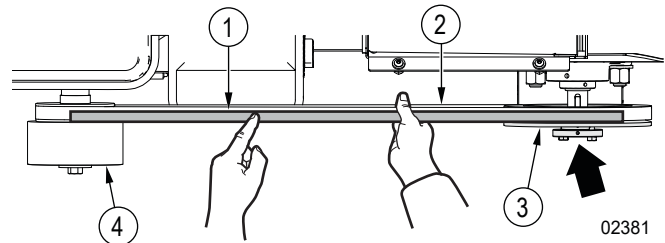

02381

**Figure 39**—Align the engine mount

- |                  |                           |
|------------------|---------------------------|
| 1. Straight edge | 3. Rotor sheave           |
| 2. Drive belt    | 4. Engine clutch flywheel |

## 9.9 Rotor Knife Maintenance

### **! WARNING!**

Do not operate the machine with any of the guards or shields removed. The machine is shown with guards or shields removed for illustrative purposes only.

W001

### **! WARNING!**

Do not reach into the rotor housing. The rotor and ledger knives are very sharp. If it is necessary to reach into the rotor housing, set the machine to a safe condition, wear heavy gloves, and be very careful.

W003

There are two offset, evenly-spaced rotor knives attached to the rotor. There is one ledger knife attached to the bottom of the chipper hopper.

### 9.9.1 Replace a Rotor Knife

1. Stop the engine. Wait for the rotor to stop turning.  
For instructions, see *Stop the Machine* on page 32.
2. Remove the fastener that holds the upper rotor housing closed. See *Figure 22* on page 36.
3. Open the upper rotor housing.
4. Turn the rotor to access one of the rotor knives.
5. Prevent the rotor from turning.  
Make sure that the rotor cannot move.
6. Remove the rotor knife fasteners.
7. Carefully remove the rotor knife.
8. Clean the rotor knife recess.
9. Apply blue 242 thread locker to the threads of each rotor knife fastener.
10. Put the rotor knife in the recess and align the fastener holes.
11. Install the rotor knife fasteners. See *Figure 40*.
12. Use a calibrated torque wrench to torque the fasteners to **45 lbf•ft (63 N•m)**.
13. Do steps 4 to 12 again for each rotor knife.
14. Release the rotor.  
Make sure that the rotor can turn freely.
15. Turn the rotor to check the ledger knife clearance for each of the rotor knives.  
Make sure that the rotor knives do not touch the ledger knife

16. Close the upper rotor housing.
17. Install the fastener that holds the upper rotor housing closed. See *Figure 22* on page 36.
18. Use a calibrated torque wrench to torque the fastener to **33 lbf•ft (45 N•m)**.

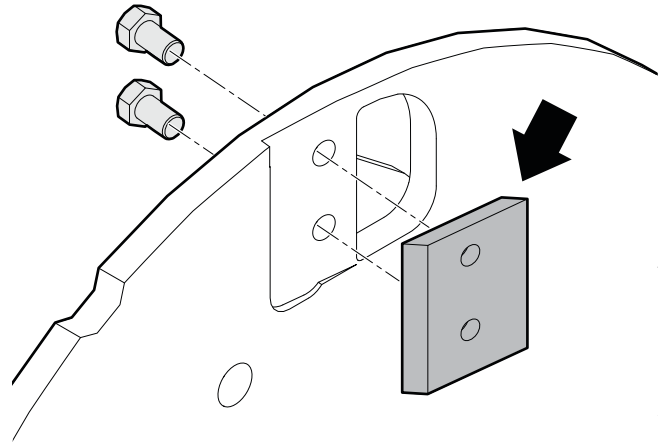

02343

**Figure 40**—Install a rotor knife

## 9.9.2 Sharpen a Rotor Knife

### CAUTION!

Wear heavy gloves and handle the rotor knives with care. The rotor knives are sharp.

W126

**IMPORTANT!** If the rotor knife gets hot during sharpening, stop and wait for the rotor knife to cool.



Remove the same amount of material from each of the rotor knives.

1. Remove the rotor knife from the machine.  
For instructions, see *Replace a Rotor Knife on page 58*.
2. Clean the rotor knife.
3. Examine the rotor knife for damage. If the rotor knife is damaged, replace all the rotor knives.
4. Put the rotor knife in a bench vice with the cutting edge facing up.  
Make sure that the rotor knife is clamped safely in the bench vice.
5. Use a grinder to sharpen the cutting edge of the rotor knife. Sharpen the cutting edge to a 45-degree angle. See *Figure 41*.
6. Do steps 4 and 5 for the opposite cutting edge.
7. Do steps 1 to 6 for the remaining rotor knives.

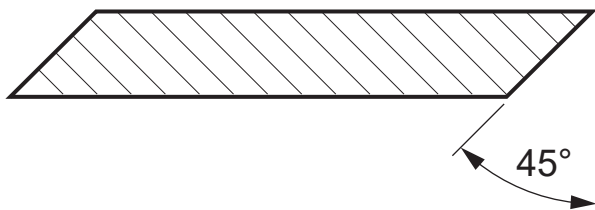

**Figure 41** – Sharpen to a 45° angle

## 9.10 Ledger Knife Maintenance

### WARNING!

Do not operate the machine with any of the guards or shields removed. The machine is shown with guards or shields removed for illustrative purposes only.

W001

### WARNING!

Do not reach into the rotor housing. The rotor and ledger knives are very sharp. If it is necessary to reach into the rotor housing, set the machine to a safe condition, wear heavy gloves, and be very careful.

W003

### 9.10.1 Replace a Ledger Knife

1. Stop the engine. Wait for the rotor to stop turning.  
For instructions, see *Stop the Machine on page 32*.
2. Remove the fastener that holds the upper rotor housing closed. See *Figure 22 on page 36*.
3. Open the upper rotor housing.
4. Remove the two ledger knife fasteners.
5. Carefully, remove the ledger knife.
6. Do one of the following:
  - If the ledger knife has a square (90-degree) edge, install the ledger knife with the square edge pointing toward the rotor knife.
  - If the ledger knife does not have a square edge, sharpen or replace the ledger knife.  
For instructions, see *Sharpen a Ledger Knife on page 60*.
7. Align the ledger knife with the bolt holes in the lower rotor housing.
8. Install the ledger knife fasteners. See *Figure 42 on page 60*.
9. Set the ledger knife clearance.  
For instructions, see *Set the Ledger Knife Clearance on page 60*.
10. Use a calibrated torque wrench to torque the fasteners to **45 lbf•ft (63 N•m)**.
11. Close the upper rotor housing.
12. Install the fastener that holds the upper rotor housing closed. See *Figure 22 on page 36*.
13. Use a calibrated torque wrench to torque the fastener to **33 lbf•ft (45 N•m)**.

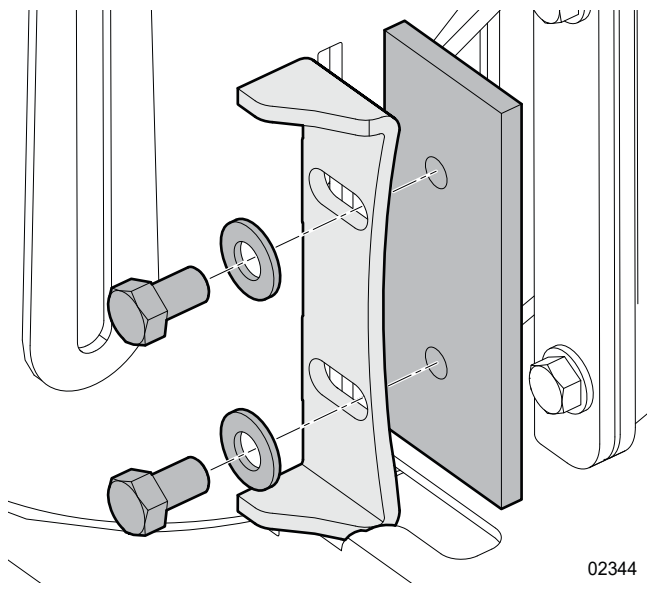
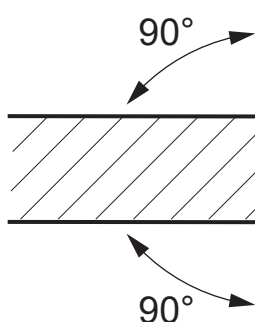

Figure 42—Install a ledger knife

## 9.10.2 Sharpen a Ledger Knife

**IMPORTANT!** If the ledger knife gets hot during sharpening, stop and wait for the ledger knife to cool.

1. Remove the ledger knife from the machine.  
For instructions, see *Replace a Ledger Knife on page 59*.
2. Clean the ledger knife.
3. Examine the ledger knife for damage. If a ledger knife is damaged, replace the ledger knife.
4. Put the ledger knife in a bench vice with the cutting edge facing up.  
Make sure that the ledger knife is clamped safely in the bench vice.
5. Use a grinder to sharpen the cutting edge of the ledger knife to a 90-degree angle. See *Figure 43*.
6. Do steps 4 and 5 for the opposite cutting edge.



01098

Figure 43—Sharpen to a 90° angle

## 9.10.3 Set the Ledger Knife Clearance

1. Stop the engine. Wait for the rotor to stop turning.  
For instructions, see *Stop the Machine on page 32*.
2. Remove the fastener that holds the upper rotor housing closed. See *Figure 22 on page 36*.
3. Open the upper rotor housing.
4. Turn the rotor to align a rotor knife with the ledger knife.  
Select the rotor knife that has the least space between the rotor knife and the ledger knife.
5. Loosen the ledger knife fasteners.
6. Do one of the following:
  - Insert a ledger knife clearance gauge between the rotor knife and the ledger knife.  
Move the ledger knife until the ledger knife touches the ledger knife clearance gauge. See *Figure 44 on page 61*.
  - Move the ledger knife to set the clearance between 1/32" and 1/16" (1 mm and 1.5 mm).
7. Tighten the ledger knife fasteners.
8. Use a calibrated torque wrench to torque the fasteners to **45 lbf•ft (63 N•m)**.
9. Do one of the following:
  - If you are using a ledger knife clearance gauge, remove it and then put it in the holder.
  - If you are not using a ledger knife clearance gauge, continue with step 9.
10. Turn the rotor to check the ledger knife clearance for each of the rotor knives.  
Make sure that the rotor knives do not touch the ledger knife
11. Close the upper rotor housing.
12. Install the fastener that holds the upper rotor housing closed. See *Figure 22 on page 36*.
13. Use a calibrated torque wrench to torque the fastener to **33 lbf•ft (45 N•m)**.

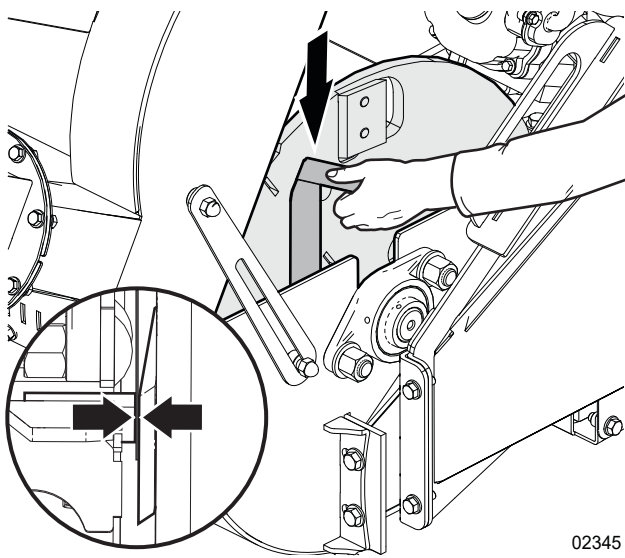

Figure 44—Set the ledger knife clearance

## 9.11 Chop Block Maintenance

**Check the chop block after every 50 hours of operation.**

The chop block is located on the rear lower rotor housing. The chop block breaks the material into smaller pieces to make it mulch when the shredder knives move through it.

If the chop block is not sharp, remove it, and then install it with the opposite side facing up. Replace the chop block if the two sides are not sharp or it is damaged.

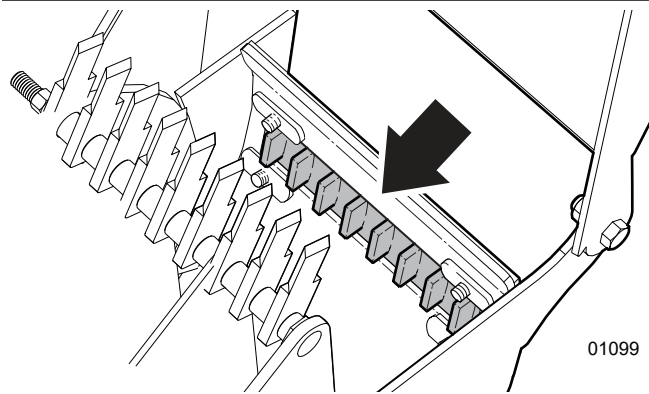

Figure 45—Chop block inside the lower rotor housing

The following procedure describes how to replace a chop block:

1. Stop the engine. Wait for the rotor to stop turning. For instructions, see *Stop the Machine on page 32*.
2. Remove the fastener that holds the upper rotor housing closed. See *Figure 22 on page 36*.
3. Open the upper rotor housing.
4. Remove the four chop block fasteners.
5. Carefully, remove the chop block.
6. Do one of the following:
  - Install the chop block with the opposite side facing up.
  - Install a new chop block.
7. Install the chop block fasteners.
8. Use a calibrated torque wrench to torque the fastener to **33 lbf•ft (45 N•m)**.
9. Close the upper rotor housing.
10. Install the fastener that holds the upper rotor housing closed. See *Figure 22 on page 36*.
11. Use a calibrated torque wrench to torque the fastener to **33 lbf•ft (45 N•m)**.

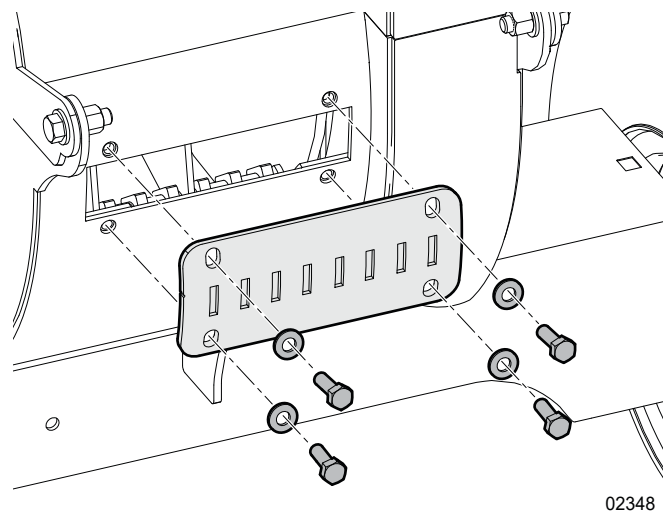

Figure 46—Install a chop block

## 9.12 Shredder Knife Maintenance

### WARNING!

Do not operate the machine with any of the guards or shields removed. The machine is shown with guards or shields removed for illustrative purposes only.

W001

Check the shredder knife sharpness after every 50 hours of operation.

There are three sets of shredder knives attached to the shredder rotor. Each shredder knife has an edge that cuts and chops the material. The chop block breaks the material into smaller pieces to make it mulch when the shredder knives move through it.

Each shredder knife has two sharp edges that can be sharpened. Replace a shredder knife that is damaged or cannot be sharpened.

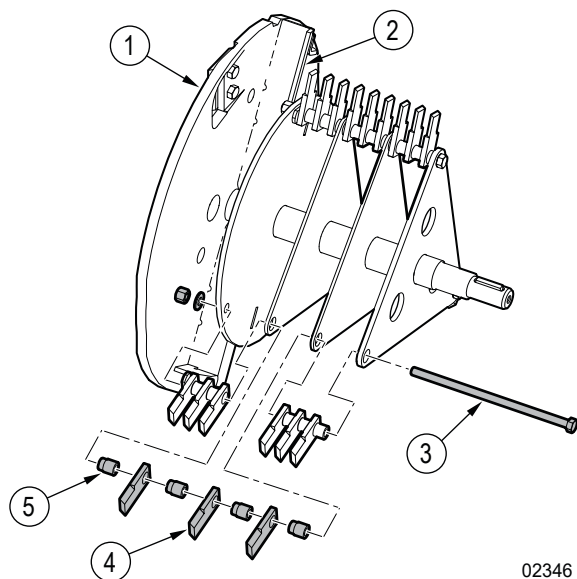

Figure 47 – Rotor and shredder knives

- |                        |                             |
|------------------------|-----------------------------|
| 1. Rotor               | 4. Shredder knife (1 of 27) |
| 2. Rotor paddle        | 5. Spacer (1 of 27)         |
| 3. Shredder-knife bolt |                             |

### 9.12.1 Replace a Shredder Knife

1. Stop the engine. Wait for the rotor to stop turning. For instructions, see *Stop the Machine* on page 32.
2. Remove the fastener that holds the upper rotor housing closed. See *Figure 22* on page 36.
3. Open the upper rotor housing.
4. Turn the rotor to access one set of shredder knives.
5. Loosen the bolt that holds a set of shredder knives and spacers to the shredder rotor.
6. Slowly, remove the shredder-knife fastener while you collect the shredder knives and spacers.
7. Turn, sharpen, or replace the shredder knives. For more information, see *Sharpen a Shredder Knife*.
8. Apply blue 242 thread locker to the threads of the shredder-knife fastener.
9. Install the shredder-knife fastener through the shredder rotor, spacers, and shredder knives.
10. Use a calibrated torque wrench to torque the fastener to **33 lbf•ft (45 N•m)**.
11. Do steps 4 to 10 again on each set of shredder knives.
12. Close the upper rotor housing.
13. Install the fastener that holds the upper rotor housing closed. See *Figure 22* on page 36
14. Use a calibrated torque wrench to torque the fastener to **33 lbf•ft (45 N•m)**.

### 9.12.2 Sharpen a Shredder Knife



Remove the same amount of material from each of the shredder knives.

1. Remove the shredder knife from the machine. For instructions, see *Replace a Shredder Knife*.
2. Clean the shredder knife.
3. Examine the shredder knife for damage. If the shredder knife is damaged, replace it. Make sure that the shredder knives are the same size.
4. Put the shredder knife in a bench vice with the cutting edge facing up. Make sure that the shredder knife is clamped safely in the bench vice.
5. Use a grinder to sharpen the cutting edge of the shredder knife. Sharpen the cutting edge to a 45-degree angle. See *Figure 41* on page 59.
6. Do steps 4 and 5 again for the opposite cutting edge.
7. Do steps 1 to 5 again for the remaining shredder knives.

## 9.13 Clean the Machine

**IMPORTANT!** Do not use gasoline, diesel fuel, or thinners for cleaning. Harsh chemicals can damage the machine finish.

**IMPORTANT!** Do not direct the spray from a pressure washer onto the following components:

- The product identification plate.
- Bearings
- Electrical components, including electrical cables.

**A pressure washer can damage these components.**

1. Use a hose or pressure washer and mild detergent to remove dust, dirt, and debris.
2. Use a clean, soft cloth, that is dampened with water to remove dirt from the product identification plate.
3. Start the machine.  
For instructions, see *Start the Machine on page 32*.
4. Let the engine run for a few minutes to dry.
5. Stop the machine.  
For instructions, see *Stop the Machine on page 32*.
6. Apply grease to the areas where the pressure washer possibly removed it.  
For instructions, see *Grease Points on page 48*.

## 9.14 Safety Curtain Maintenance



Do not operate the machine without the safety curtain installed in the chipper hopper. Replace the safety curtain if it is damaged or missing. The safety curtain prevents wood chips from being blown out of the chipper hopper. The machine can release wood chips fast enough to cause personal injury and property damage.

W119

The safety curtain is located on the inside of the chipper hopper.

The following procedure describes how to replace the safety curtain:

1. Set the machine to a safe condition.  
For instructions, see *Safe Condition on page 9*.
2. Remove the fasteners that attach the safety curtain to the chipper hopper.
3. Put the new safety curtain in position.
4. Install the fasteners that attach the safety curtain to the chipper hopper.
5. Use a calibrated torque wrench to torque the fasteners to **9 lbf•ft (12 N•m)**.

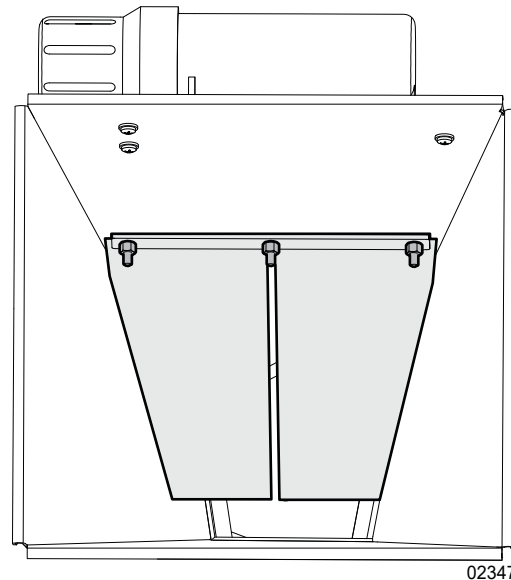

02347

**Figure 48**—Safety curtain

# 10. Troubleshooting



## WARNING!

**Before troubleshooting, read and understand the *Service and Maintenance Safety on page 44.* Set the machine to a safe condition.**

If you find a problem that is difficult to solve, even after reading this information, please contact your local dealer, the distributor, or Wallenstein Equipment. When you contact someone, please have the serial number of your product available. To find the serial number on your machine, see *Serial Number Location on page 5.*

For engine troubleshooting, see the engine manufacturer's manual.

The following table lists some of the problems that can occur and gives possible causes and solutions.

Problem	Possible cause	Solution
<b>The rotor does not turn.</b>	The discharge chute is obstructed.	Remove all material from the discharge chute. For instructions, see <i>page 36.</i>
	The rotor is blocked.	Remove the blockage. For instructions, see <i>page 36.</i>
	The drive belt is loose or broken.	Set the drive belt tension. For instructions, see <i>page 55.</i>
	The clutch is seized.	Replace the clutch.
<b>Material is moving into the machine too slowly.</b>	The engine or rotor speed is too slow.	Set the engine throttle to <b>Fast</b> to increase the rotor RPM. See <i>page 22.</i>
	The knives are not sharp or the clearance is incorrect.	Check the rotor and ledger knives. If necessary, rotate, sharpen, or replace the knives. For instructions, see <i>page 58</i> and <i>page 59.</i>
	The rotor knife angle is incorrect.	Sharpen the rotor knives to the specified 45° angle and check that the knives are installed correctly. For instructions, see <i>page 59.</i>
	The discharge chute is blocked.	Remove all material from the discharge chute. For instructions, see <i>page 36.</i>
<b>There is unusual machine vibration during operation.</b>	A rotor knife is broken or missing.	Check the rotor knives. If necessary, rotate, sharpen, or replace the knives. For instructions, see <i>page 58.</i>
	The rotor could be bent.	Turn the rotor to see if it wobbles. If the rotor wobbles, replace the rotor.
	The rotor bearings failed.	Replace the rotor bearings.
	Fasteners are loose.	Use a calibrated torque wrench to torque the fasteners to the correct specifications. See <i>page 67.</i>
<b>The engine does not start.</b>	There is a problem with the engine.	See the engine manufacturer's manual.
	The clutch is seized.	Replace the clutch.
<b>The wood chip quality is poor.</b>	The knives are not sharp.	Check the rotor and ledger knives. If necessary, rotate, sharpen, or replace the knives. For instructions, see <i>page 58</i> and <i>page 59.</i>
	The drive belt is loose or worn.	Examine the drive belt. If necessary, adjust the tension or replace the drive belt. For instructions, see <i>page 54.</i>
	The material being chipped is poor quality.	The material is small or rotting. Mix the material with higher quality material.
	The ledger knife clearance is incorrect.	Set the ledger knife clearance. For instructions, see <i>page 60.</i>
<b>The mulch is too coarse.</b>	The chop block is damaged.	Examine the chop block for damage. If necessary, turn or replace the chop block. For instructions, see <i>page 61.</i>
	The ledger knife is broken or missing.	Replace the ledger knife. For instructions, see <i>page 59.</i>
	One or more shredder knives are broken or missing.	Replace the shredder knives. For instructions, see <i>page 62.</i>
	The shredder knives are installed incorrectly.	Check the shredder knives and, if necessary, adjust them. For instructions, see <i>page 62.</i>



Problem	Possible cause	Solution
<b>The machine needs more power or the engine stalls.</b>	The discharge chute is blocked.	Remove all material from the discharge chute. For instructions, see <i>page 36</i> .
	Too much material is being put into the chipper hopper.	Put smaller amounts of material in the chipper hopper.
	Material is being put into the chipper hopper too quickly.	Put large material into the chipper hopper slowly.
	The rotor is blocked.	Remove the blockage. For instructions, see <i>page 36</i> .
	Wet (green) material does not discharge.	Wait for the material to dry or alternate between dry and wet material.
	The ledger knife clearance is incorrect.	Set the ledger knife clearance. For instructions, see <i>page 60</i> .
	The knives are not sharp or the clearance is incorrect.	Check the rotor and ledger knives. If necessary, rotate, sharpen, or replace the knives. For instructions, see <i>page 58</i> and <i>page 59</i> .
	There is a problem with the engine.	See the engine manufacturer's manual.
<b>The drive belt is noisy or there is premature wear.</b>	The drive belt is loose, worn, or the tension is too tight.	Examine the drive belt. If necessary, adjust the tension or replace the drive belt. For instructions, see <i>page 54</i> .
	An incorrect replacement belt was installed.	Replace the drive belt. For instructions, see <i>page 54</i> .
	The rotor sheave is misaligned.	Check the rotor sheave alignment. If necessary, adjust the alignment. For instructions, see <i>page 57</i> .
	The rotor is blocked.	Remove the blockage. For instructions, see <i>page 36</i> .
	The rotor sheave is worn.	Examine the rotor sheave and bearings. If necessary, replace the components.
	There is lubricant (for example, oil or grease) on the drive system components.	Find the source of the lubricant and correct the situation. Clean the drive system components. If necessary, replace the drive belt.
	The rotor bearings are worn or damaged.	Examine the rotor bearings. Replace a bearing that is worn or damaged

# 11. Specifications

For engine specifications, see the engine manufacturer's manual.

For available accessories, go to [WallensteinEquipment.com](http://WallensteinEquipment.com)

## 11.1 Machine Specifications<sup>1</sup>

Parameter	BXMT32G
Chipper type	Disc
Shredder type	Hammer mill
Feed system	Gravity
Engine	Vanguard® 14 hp (408 cc)
Chipper hopper opening (height x width)	14" x 15" (35 cm x 38 cm)
Chipper rotor opening (height x width)	3" x 6" (7 cm x 15 cm)
Shredder hopper opening (height x width)	27" x 29" (68 cm x 73 cm)
Shredder housing opening (height x width)	7.8" x 10" (19 cm x 25 cm)
Number of rotor knives	2
Number of shredder knives	27
Rotor diameter	18" (45 cm)
Rotor weight	65 lb (29 kg)
Discharge chute height	58" (147 cm)
Discharge chute rotation	310°
Drive system	Centrifugal clutch, belt drive
Engine speed	3,600 RPM
Rotor speed	1,750 RPM
Tires	4.80 x 8
Hitch	Clevis
Total weight	500 lb (226 kg)
Dimensions (length x width x height)	64" x 49" x 58" (162 cm x 124 cm x 147 cm)
Fuel tank capacity	1.59 US gal (6 l)
Chipper capacity (diameter)	3" (8 cm)
Shredder capacity (diameter or width)	1" (2.5 cm)
Tongue weight	92 lb (41 kg)

<sup>1</sup> Specifications are subject to change without notice.

## 11.2 Bolt Torque

**IMPORTANT!** If you replace hardware, use fasteners of the same grade.

**IMPORTANT!** The torque specifications in these tables are for non-greased or non-oiled threads. Do not grease or oil fastener threads unless otherwise indicated. When using a thread lock, increase the specified torque 5%.



Bolt grades are identified by the marks on top of the bolt head.

These bolt torque specification tables give the correct torque settings for common bolts and capscrews. Tighten all bolts to the torque that is specified in the table, unless otherwise indicated. Check the bolt tightness periodically.

### Imperial Bolt Torque Specifications

Bolt Diameter	Torque					
	SAE Gr. 2		SAE Gr. 5		SAE Gr. 8	
	lbf•ft	N•m	lbf•ft	N•m	lbf•ft	N•m
1/4 inch	6	8	9	12	12	17
5/16 inch	10	13	19	25	27	36
3/8 inch	20	27	33	45	45	63
7/16 inch	30	41	53	72	75	100
1/2 inch	45	61	80	110	115	155
9/16 inch	60	95	115	155	165	220
5/8 inch	95	128	160	215	220	305
3/4 inch	165	225	290	390	400	540
7/8 inch	170	230	420	570	650	880



SAE Gr. 2



SAE Gr. 5



SAE Gr. 8

### Metric Bolt Torque Specifications

Bolt Diameter	Torque			
	Gr. 8.8		Gr. 10.9	
	lbf•ft	N•m	lbf•ft	N•m
M3	0.4	0.5	1.3	1.8
M4	2.2	3	3.3	4.5
M6	7	10	11	15
M8	18	25	26	35
M10	37	50	52	70
M12	66	90	92	125
M14	83	112	116	158
M16	166	225	229	310
M20	321	435	450	610
M30	1,103	1,495	1,550	2,100



8.8



10.9

## 12. Warranty



### LIMITED WARRANTY

Wallenstein products are warranted to be free of defects in materials and workmanship under normal use and service, for a period of

**Five Years for Consumer Use**

**Two Years for Commercial/Rental Use**

from the date of purchase, when operated and maintained in accordance with the operating and maintenance instructions supplied with the unit. Warranty is limited to the repair of the product and/or replacement of parts.

This warranty is extended only to the original purchaser and is not transferable.

Repairs must be done by an authorized dealer. Products will be returned to the dealer at the customer's expense. Include the original purchase receipt with any claim.

**This warranty does not cover the following:**

- 1) Normal maintenance or adjustments
- 2) Normal replacement of wearable and service parts
- 3) Consequential damage, indirect damage, or loss of profits
- 4) Damages resulting from:
  - Misuse, negligence, accident, theft or fire
  - Use of improper or insufficient fuel, fluids or lubricants
  - Use of parts or aftermarket accessories other than genuine Wallenstein parts
  - Modifications, alteration, tampering or improper repair performed by parties other than an authorized dealer
  - Any device or accessories installed by parties other than an authorized dealer
- 5) Engines. Engines are covered by the manufacturer of the engine for the warranty period they specify. For the details of your engine warranty, see your engine owner's manual. Information about engine warranty and service is also available in the FAQ section at [www.wallensteinequipment.com](http://www.wallensteinequipment.com)

# 13. Index

	<b>A</b>		
Air filter, clean.....		51	
Alert symbol, safety.....		7	
	<b>B</b>		
Battery			
Charge.....		53	
Clean.....		53	
Install.....		52	
Remove.....		52	
Safety.....		52	
Blockage, remove.....		36	
Bolt torque specifications.....		67	
Break-in.....		27	
	<b>C</b>		
Caution, notation.....		7	
Checklist			
Dealer inspection.....		4	
Pre-start.....		27	
Chip wood.....		34	
Choke.....		22	
Chop block, maintenance.....		61	
Clean			
Battery.....		53	
Engine air filter.....		51	
Machine.....		63	
Clearance, ledger knife.....		60	
Clevis hitch			
Connect.....		40	
Disconnect.....		40	
Components.....		21	
Connect, clevis hitch.....		40	
Controls.....		22	
Deflector.....		24	
Discharge chute.....		24	
Engine.....		22	
Hitch handle.....		25	
Rotor Lock.....		46	
Shredder gate.....		25	
Curtain, safety.....		63	
	<b>D</b>		
Danger, notation.....		7	
Deflector.....		24	
Disconnect, clevis hitch.....		40	
Drive belt			
Align.....		56	
Maintenance.....		54	
Replace.....		54	
Set the tension.....		55	
	<b>E</b>		
Emergency stop.....		32	
Engine			
Air filter, clean.....		51	
Controls.....		22	
Choke.....		22	
Fuel shutoff.....		22	
Ignition switch.....		23	
Rewind start.....		23	
Throttle.....		22	
Fuel			
Add.....		30	
Level check.....		30	
Replace.....		43	
Specifications.....		46	
Maintenance and safety.....		51	
Oil			
Add.....		31	
Level check.....		31	
Specifications.....		46	
Operation.....		28	
Safety.....		28, 51	
Specifications.....		66	
Speed.....		66	
Equipment safety guidelines.....		9	
	<b>F</b>		
Familiarization.....		20	
Components, machine.....		21	
Operator, new.....		20	
Orientation, Operator.....		20	
Training.....		20	
Filter, clean.....		51	
Fire extinguisher.....		8	
First-aid kit.....		8	
Fluids.....		46	
Form, sign-off.....		10	
Fuel			
Add.....		30	
Level, check.....		30	
Replace.....		43	
Safety.....		29	
Shutoff.....		22	
Specifications.....		46	
	<b>G</b>		
Gate, shredder.....		25	
Grease			
Fitting locations.....		49	
Points.....		48	
Specifications.....		46	
	<b>H</b>		
Hinge lubricant			
Locations.....		50	
Specifications.....		46	
Hitch handle.....		25	
	<b>I</b>		
Ignition switch.....		23	
Important, notation.....		7	
Information			
Labels.....		6	
Product plate.....		5	
Inspection report.....		4	
	<b>J</b>		
Jack stand.....		40	



Service.....	45
Signal words .....	7
Storage .....	42
Training.....	9
Transport .....	38
Work site.....	11
Safe work area .....	12
Serial number location .....	5
Service and maintenance.....	45
Battery maintenance.....	52
Chop block maintenance .....	61
Drive belt maintenance .....	54
Engine maintenance .....	51
Fluids .....	46
Grease points .....	48
Ledger knife maintenance .....	59
Lubricants .....	46
Rotor knife maintenance.....	58
Safety.....	45
Safety curtain maintenance .....	63
Shredder knife maintenance.....	62
Tire maintenance .....	53
Set up machine .....	33
Sharpen	
Ledger knife .....	60
Rotor knife .....	59
Shredder knife .....	62
Shredder	
Gate .....	25
Knife	
Maintenance.....	62
Replace .....	62
Sharpen.....	62
Shred material.....	35
Sign-off form.....	10
Specifications .....	66
Bolt torque .....	67
Fuel, engine .....	46
Grease .....	46
Machine .....	66
Oil, engine.....	46
Rust protection lubricant.....	46
Stand· See Jack stand	
Standards.....	10
Start	
Ignition switch .....	23
Machine .....	32
Rewind.....	23
Stop	
Emergency.....	32
Machine .....	32
Storage.....	42
Put machine.....	42
Remove machine.....	42
Replace engine fuel .....	43
Safety.....	42
Support.....	3
Switch, ignition .....	23
Symbol, safety alert.....	7

**T**

Throttle .....	22
Tire	
Maintenance .....	53
Safety.....	53
Specifications.....	66
Torque, bolt specifications.....	67
Training	
Operator.....	20
Safety.....	9
Transport.....	38
Prepare .....	38
Safety.....	38
Troubleshooting .....	64

**W**

Warning notation .....	7
Warranty.....	68
Work site .....	11
Safety.....	11
Select.....	11



**MAKING WORK FEEL MORE LIKE PLAY™**

[WallensteinEquipment.com](http://WallensteinEquipment.com)

