

OPERATOR'S MANUAL

WP845 serial number 2E9US1112MS045082 to 2E9US1110PS045232, and 1100000 to 1101347

WP875 serial number 2E9US1118MS0875010 to 2E9US1114PS0875025, and 1100000 to 1101347

WP845 / WP875 **Firewood Processor**

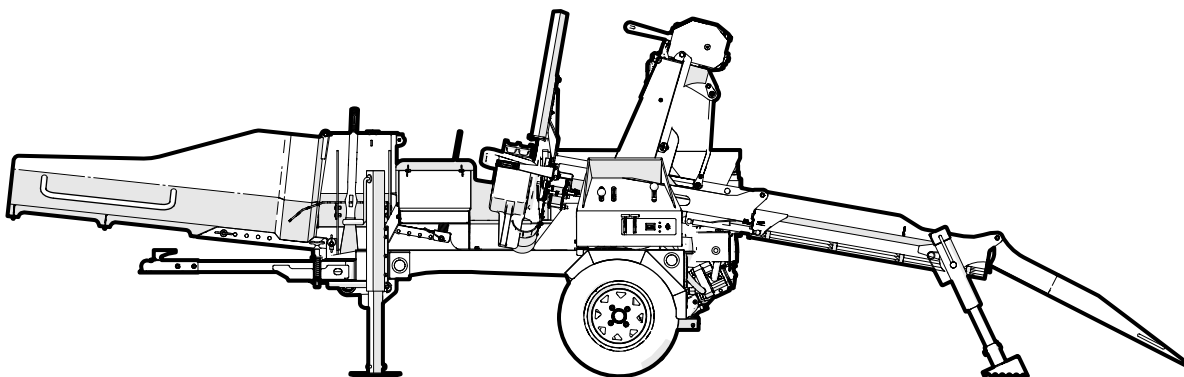

Table of Contents

1. Foreword	3	6.8 Emergency Stop	32
1.1 Introduction	3	6.9 Process Logs into Firewood.....	32
1.2 Delivery Inspection Report	4	6.10 Machine Setup.....	33
1.3 Serial Number Location.....	5	6.11 Attach a Chain Saw to the Holder	38
1.4 Types of Decals on the Machine	6	6.12 Winch Operation	40
2. Safety	7	6.13 Position the First Log	43
2.1 Safety Alert Symbol	7	6.14 Cut Logs.....	45
2.2 Signal Words	7	6.15 Split Logs	47
2.3 Why SAFETY is Important	7	6.16 Split Wood Discharge	48
2.4 Safety Rules	8	6.17 Position the Next Log.....	48
2.5 Equipment Safety Guidelines	9	6.18 Position the Last Log	48
2.6 Safe Condition	9	7. Transport	49
2.7 Safety Training.....	9	7.1 Transport Safety	49
2.8 Sign-Off Form.....	10	7.2 Prepare the Machine for Transport	49
2.9 Create a Safe Work Area	11	7.3 Attach to a Tow Vehicle	52
3. Safety Signs	12	8. Storage	54
3.1 Safety Sign Locations	13	8.1 Storage Safety	54
3.2 Safety Sign Explanations.....	15	8.2 Place the Machine in Storage.....	54
3.3 Replace Damaged or Missing Safety Signs.....	17	8.3 Remove the Machine from Storage	54
4. Familiarization	18	9. Service and Maintenance	56
4.1 New Operator	18	9.1 Service and Maintenance Safety.....	56
4.2 Training.....	18	9.2 Fluids and Lubricants.....	57
4.3 Work Site Familiarization	18	9.3 Maintenance Schedule.....	58
4.4 Operator Orientation.....	18	9.4 Grease Points	59
4.5 Machine Components	19	9.5 Change the Hydraulic Fluid and Filter.....	60
5. Controls	20	9.6 Clean the Engine Air Filter.....	61
5.1 Engine Controls	20	9.7 Winch Rope Maintenance	61
5.2 Hydraulic Controls	21	9.8 Tire Maintenance	62
5.3 Splitting-Wedge Height Adjustment Lever	23	10. Troubleshooting	63
5.4 Log-length Guide	23	11. Specifications	64
5.5 Splitter Chute Height Adjustment.....	24	11.1 Machine Specifications	64
6. Operating Instructions	25	11.2 Common Bolt Torque.....	65
6.1 Operating Safety	25	11.4 Wheel Lug Nut Torque	66
6.2 Pre-start Checklist	26	11.3 Hydraulic Fitting Torque	66
6.3 Machine Break-In.....	26	12. Product Warranty	67
6.4 Engine Operation	27	13. Index	68
6.5 Hydraulic System Operation.....	30		
6.6 Start the Machine.....	32		
6.7 Stop the Machine.....	32		

1. Foreword

WARNING!

Do not attempt to start or operate the machine before you read this manual thoroughly. Make sure that you understand how to operate the machine correctly and safely before you use it.

Keep this manual with the machine at all times.

W034

Wallenstein 800 Series firewood processors improve firewood productivity and minimize handling, while reducing the risk of physical strain.

Keep this manual handy for frequent reference and to pass on to new operators or owners. Call your local Wallenstein dealer or the distributor if you need assistance, information, or additional copies of the manuals.

Units of measurement in Wallenstein Equipment technical manuals are written as: US Customary (SI metric)

Wallenstein Equipment Inc. • © 2022. All rights reserved.

No part of this work may be copied, reproduced, replaced, distributed, published, displayed, modified, or transferred in any form or by any means except with the prior permission of Wallenstein Equipment Inc.

1.1 Introduction

Congratulations on your choice of a Wallenstein firewood processor!

This high-quality machine is designed and manufactured to meet the needs of a proficient timber or woodlot industry.

800 Series firewood processors include a hydraulic power source, a winch, and a splitter. The machine is powered by a Vanguard® 14 hp (10.3 kW) engine.

The difference between the two models is the splitting cradle size:

Model	Splitting cradle size
WP845	25" (61 cm)
WP875	36" (91 cm)

The hydraulic winch is mounted on top of the machine to winch logs up the lead-in chute and position them for cutting. After the operator cuts the log with a chain saw, the cut log rolls into the splitting cradle. The operator then activates the push block to split the cut log into firewood and push it out of the machine.



1.2 Delivery Inspection Report

Wallenstein WP845 or WP875 Firewood Processor

To activate the warranty, register your product through the Support page at WallensteinEquipment.com.

This form must be completed by the dealer at the time of delivery, and then signed by the dealer and customer.

I received the product manuals and was thoroughly instructed about the care, adjustments, safe operation, and applicable warranty policy.

I thoroughly instructed the customer about the equipment care, adjustments, safe operation, and applicable warranty policy, and reviewed the manuals with them.

Customer

Dealer

Address

Address

City, State/Province, ZIP/Postal Code

City, State/Province, ZIP/Postal Code

()

()

Phone Number

Phone Number

Contact Name

Model

Serial Number

Delivery date

Dealer Inspection Checklist

_____ Engine starts and runs, and fluid levels are correct.

_____ Chutes fold up and latch securely.

_____ Log stabilizer moves freely.

_____ All fasteners are tightened to the correct torque.

_____ All grease points are lubricated.

_____ Hydraulic system and cylinders function correctly.

_____ Hydraulic controls move freely.

_____ Hydraulic connections are tight, and hoses and fittings are in good condition.

_____ There are no hydraulic leaks.

_____ The wedge-height adjustment functions correctly.

_____ Tire pressure is correct (see the tire sidewall).

_____ Tires are in good condition.

_____ Operator's Manual is in the storage tube.

_____ Purchased accessories are included, if applicable.

Winch

_____ Motor and gear lever function correctly.

_____ Rope, hook, and fairlead are in good condition.

Safety Checks

_____ All safety sign decals are applied and legible.

_____ All guards, shields, and covers are installed and secure.

_____ Wheel lug nuts are tightened to the correct torque.

_____ Trailer and bracing jacks function correctly.

_____ A retainer is installed through each hitch point.

_____ Safety chains are on the ball-mount hitch.

_____ All lights operate correctly (for example; running, brake, turn signal, license plate).

_____ Operating and safety instructions were reviewed.

1.3 Serial Number Location

Always provide the model and serial number of your Wallenstein product when ordering parts or requesting service or other information. The product information plate location is shown in the following illustration.

Record your product's serial number in the following table for future reference.

Record Product Information Here	
Model:	
Serial Number:	

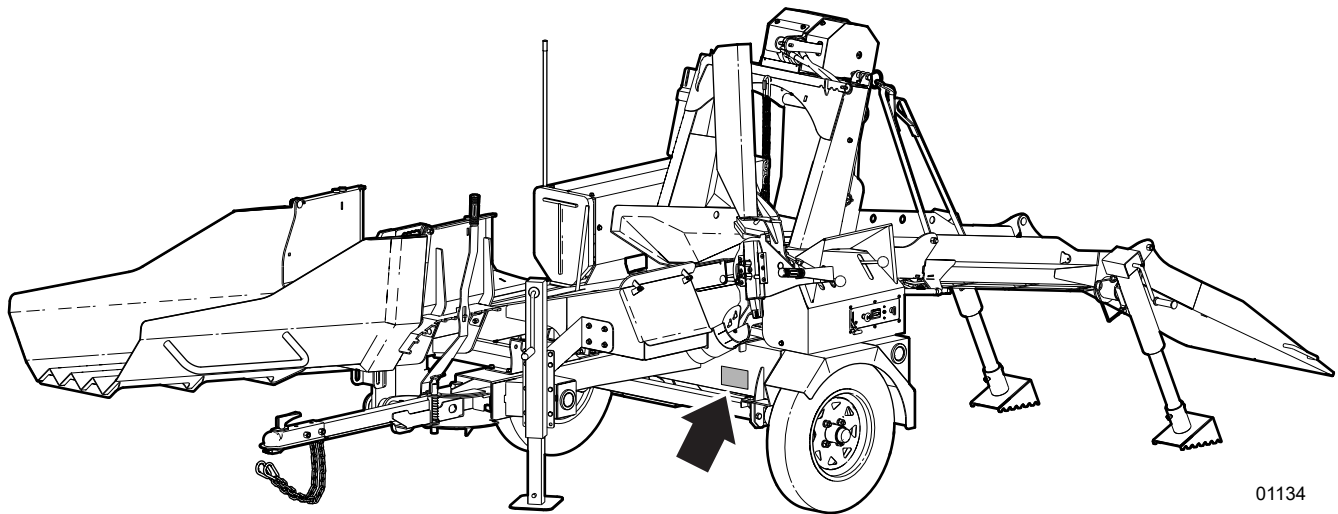
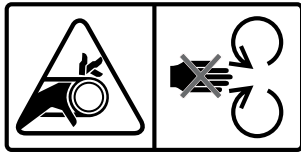

Fig. 1 – Product information plate location (typical)

1.4 Types of Decals on the Machine

When getting familiar with the Wallenstein product, notice that there are numerous decals located on the machine. There are different types of decals for safety, information, and product identification. The following section explains what they are for and how to read them.

Safety Sign Decals have a yellow background and are generally two panel. They can be either vertical or horizontal.



Safety Notice Decals are pictorial with a blue background and generally rectangular with single or multiple symbols. This decal informs what Personal Protective Equipment is required for safe operation.



Informative Decals are generally pictorial with a white background and can vary in the number of panels. This type of decal explains how a control works.

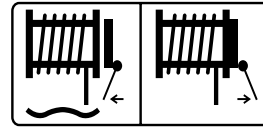

Product Decals indicate machine model and serial number, and other important information.

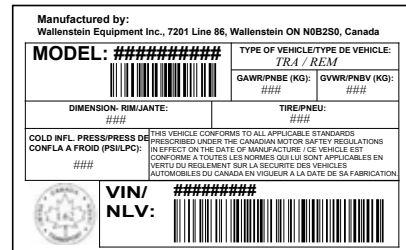

Maintenance Decals have a green background and can vary to the number of panels. This decal shows a type maintenance required and frequency interval.

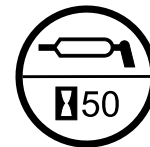

For safety sign decal definitions, see *Safety Sign Explanations* on page 15. For a complete illustration of decals and decal locations, download the parts manual for your Wallenstein product at WallensteinEquipment.com.

2. Safety

2.1 Safety Alert Symbol

This Safety Alert Symbol means:

ATTENTION! BE ALERT!

YOUR SAFETY IS INVOLVED!

The Safety Alert Symbol identifies important safety messages on the Wallenstein firewood processor and in the manual.

When you see this symbol, be alert to the possibility of personal injury or death. Follow the instructions in the safety message.



2.2 Signal Words

The signal words **DANGER**, **WARNING** and **CAUTION** determine the seriousness level of the warning messages in this manual. The appropriate signal word for each message in this manual has been selected using the following guidelines:

DANGER –

Indicates an imminently hazardous situation that, if not avoided, **will** result in death or serious injury. This signal word is to be limited to the most extreme situations typically for machine components which, for functional purposes, cannot be guarded.

WARNING –

Indicates a potentially hazardous situation that, if not avoided, **could** result in death or serious injury, and includes hazards that are exposed when guards are removed. It may also be used to alert against unsafe practices.

CAUTION –

Indicates a potentially hazardous situation that, if not avoided, **may** result in minor or moderate injury. It may also be used to alert against unsafe practices.

IMPORTANT – To avoid confusing equipment protection with personal safety messages, a signal word **IMPORTANT** indicates a situation that if not avoided, could result in damage to the machine.



Provides additional information that is helpful.

2.3 Why SAFETY is Important

- **Accidents disable and kill people.**
- **Accidents cost money.**
- **Accidents are preventable**

YOU are responsible for the SAFE operation and maintenance of your Wallenstein trailer firewood processor. **YOU** must ensure that you and anyone else who is going to use, maintain or work around the firewood processor be familiar with the operating and maintenance procedures and related **SAFETY** information contained in this manual. This manual provides good safety practices that should be followed while using this machine.

Remember, **YOU** are the key to safety. Good safety practices not only protect you but also the people around you. Make these practices a working part of your safety program. Be certain that **EVERYONE** using this equipment is familiar with the recommended operating and maintenance procedures and follows all the safety precautions. Most accidents can be prevented.

Do not risk injury or death by ignoring good safety practices.

2.4 Safety Rules

CAUTION!



Hearing loss hazard. Prolonged exposure to loud noise may cause permanent hearing loss. Use suitable protection while operating the machine.

W016

Safety is a primary concern in the design and manufacture of Wallenstein products. Unfortunately, efforts to provide safe equipment can be wiped out by a single careless act.

For safety information that is specific to machine operation, service, or maintenance, see the applicable section in this manual.

- It is the operator's responsibility to read, understand, and follow ALL safety and operating instructions in this manual.
- If you do not understand any part of this manual or require assistance, contact your local dealer, the distributor, or Wallenstein Equipment.
- Do not allow anyone to use this machine until they have read this manual. Operator's must have a thorough understanding of the safety precautions and how the machine works. Review the safety instructions with all users annually.
- Operators of this machine must be responsible, physically able people who are familiar with machinery and trained in the operation of this equipment. If an elderly person is assisting with the work, their physical limitations need to be recognized and accommodated.
- Make sure that all users understand the safety signs on the machine before operating, servicing, adjusting, or cleaning it. For safety sign decal definitions, see *Safety Sign Explanations on page 15*.
- Learn the controls and how to stop the machine quickly in the event of an emergency. For instructions, see *Emergency Stop on page 32*.
- Keep a first-aid kit available for use, should the need arise, and know how to use the contents.
- Keep a fire extinguisher available for use, should the need arise, and know how to use it.



- Wear the appropriate PPE when operating, servicing, or maintaining the machine. This includes, but is not limited to:
 - A hard hat.
 - Heavy gloves.
 - Hearing protection.
 - Protective shoes with steel toes and slip resistant soles.
 - Protective glasses, goggles, or a face shield.
- Prolonged exposure to loud noise may cause permanent hearing loss. Power equipment with or without a vehicle attached can often be noisy enough to cause permanent, partial hearing loss.



- Wear hearing protection on a full-time basis if the noise in the operator's position exceeds 80 dB. Noise over 85 dB on a long-term basis can cause severe hearing loss. Noise over 90 dB adjacent to the operator on a long-term basis may cause permanent, total hearing loss.
- Avoid wearing loose fitting clothing, loose or uncovered long hair, jewelry, and loose personal articles. These can get caught in moving parts and cause injury. Jewelry may also ground a live electrical circuit causing injury and machine damage.
- Never consume alcohol or drugs before or during machine operation. Alertness or coordination can be affected. Consult your doctor about operating this machine while taking prescription medications.
- Only use the machine in daylight or good artificial light.
- Keep all guards, shields, and covers in place. If removal is necessary for repair, replace them before using the machine.
- Never allow anyone to ride on the machine during transport.
- Keep bystanders at least 10 ft (3 m) from the stacking zone. Mark the zone with safety cones.
- Before starting the engine, make sure the machine is clear of debris.
- Handle logs with respect and be aware of other people in the area.
- Never attempt to push a log through the stabilizer opening by hand. The stabilizer could drop suddenly and cause serious injury. Always use the appropriate procedure and tools to push or pull a log through the opening.
- Do not touch hot engine parts, the muffler cover, hoses, engine body, or engine oil during operation or after the engine is turned off. Contact with hot surfaces may cause burns.

2.5 Equipment Safety Guidelines

A few seconds of thought and a careful approach to handling equipment can prevent accidents.

- Replace safety or instruction signs (decals) that are not readable or missing. For locations and explanations, see *Safety Signs on page 12*.
- Do not modify the equipment in any way. Unauthorized modifications may affect the integrity of the machine or the ability of the machine to perform as designed. Modifications can impair safety or function. They can affect the life of the equipment and void the warranty.
- Make sure the machine is correctly stationed, adjusted, and in good operating condition.
- Keep the machine free of accumulated trash, grease, and debris to prevent fires.
- Replace the winch synthetic rope if it is kinked, badly frayed, has knots, cuts, or broken strands. If the rope fails under tension, it can snap back with great force causing injury or death. Avoid sudden jerks, quick starts or stops. Start slowly and smoothly.
- Never exceed the limitations of the machine. If its ability to do the job, or to do it safely is in question—**STOP!**

2.6 Safe Condition

References are made to **safe condition** throughout this manual. Safe condition means putting the machine in a state that makes it safe to service or maintain.

Before starting any service or maintenance, complete the following:

SAFE CONDITION

1. Set the tow vehicle's parking brake, turn off the engine, and remove the ignition key.
2. Chock the machine wheels to prevent movement.
3. Remove the winch rope from the log and wind it into the winch.
4. Set the hydraulic controls to neutral and wait for all motion to stop.
5. Turn off the chain saw.
6. Turn off the engine.
7. Disconnect the engine spark-plug wire and keep it away from the spark plug.
8. Actuate each hydraulic control to relieve the pressure.
9. Remove all material from the lead-in chute, log-loader chute, splitting cradle, and splitter chute.

2.7 Safety Training

An untrained operator can cause serious injury or death to themselves or others. Review the safety instructions with all users annually. The *Sign-Off Form on page 10* can be used to keep a training record.

- An employer has the responsibility to train employees how to operate the equipment they are using. When someone does not understand the basic operation of a piece of equipment, they can create dangerous situations very quickly. Operators must completely understand the safety information in this manual and the safety decals on the machine
- Provide instruction to anyone else who is going to operate the machine. This equipment is dangerous to anyone who is unfamiliar with its operation.
- If the machine is loaned or rented, it is the owner's responsibility to make sure that, before using the machine, every operator:
 - Reads and understands this manual.
 - Is instructed in the safe and correct use of the machine and related equipment.
 - Understands and knows how to set the machine to a **Safe Condition**.
For instructions, see *Safe Condition*.

2.9 Create a Safe Work Area

WP800 Series firewood processors are designed for a person to winch, cut-to-length, and split logs for firewood. Review and follow the instructions for safe operation of the machine. Also, review the safety guidelines included with your chain saw.

A safe work area is divided into four zones:

1. **Safe Zone** – The area outside the Work Zone perimeter. Bystanders or anyone not directly involved with the work is permitted to be in this area. There are minimal potential hazards in the Safe Zone.
2. **Work Zone** – The area between the Hazard Zone and the Safe Zone. People assisting with the work who are wearing the appropriate PPE are permitted to be in this area. Some limited hazards are present in the Work Zone.
3. **Hazard Zone** – The area between the Operator Zone and the Work Zone. Only people directly involved with the work who are wearing the appropriate PPE are permitted in this area. Workers must always make eye contact with the operator before entering the Hazard Zone. Serious safety hazards are present in the Hazard Zone.
4. **Operator Zone** – The area where an operator must be to operate the machine. Only the operator is permitted to be in this area. The operator must be aware of all the people in the Hazard Zone and make eye contact with workers before they enter the Hazard Zone.

To keep bystanders and workers safe from hazards, follow these important guidelines:

- Establish a Work Zone perimeter and mark it with safety cones. The perimeter should be a minimum of 10 ft (3 m) from any hazard within the Hazard Zone. The area outside the Work Zone perimeter is the Safe Zone.
- Never allow workers to approach the Hazard Zone during machine operation, without first signaling and making eye contact with the operator.
- Keep all bystanders in the Safe Zone. Never allow bystanders in the Work or Hazard Zones.
- Always operate the machine controls from the Operator Zone (typically, located at the control panel).
- Only the operator can authorize entry into the Hazard Zone. The operator must make sure it is safe to enter first.
- Make eye contact with coworkers and have a hand-signal scheme worked out. Always be aware of the location of your coworkers.
- Use extreme caution around the material stacks. Stacked logs can roll in unpredictable ways.
- Be aware of split wood stacks. Split wood can tumble off the pile.

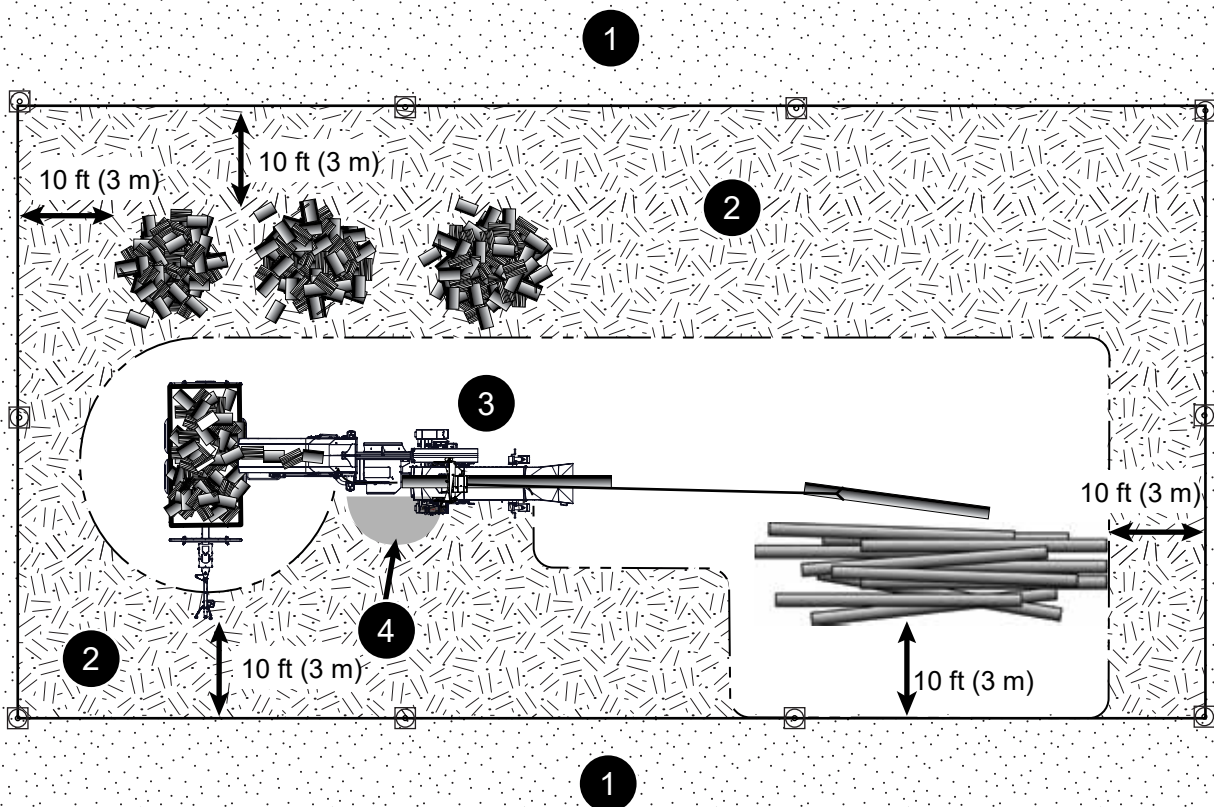

Fig. 2—Example layout of a safe work area

3. Safety Signs

! WARNING!

Risk of personal injury. Replace safety signs that are removed, damaged, or illegible. If a part with a safety sign on it is replaced, a new safety sign must be applied.

W100

Practicing good safety means becoming familiar with safety signs (decals) and warnings and being aware of situations that require alertness.

The top panel (or left-hand panel for horizontal signs) shows the safety alert (potential hazard), and the bottom (or right-hand) panel shows the message (how to avoid the hazard).

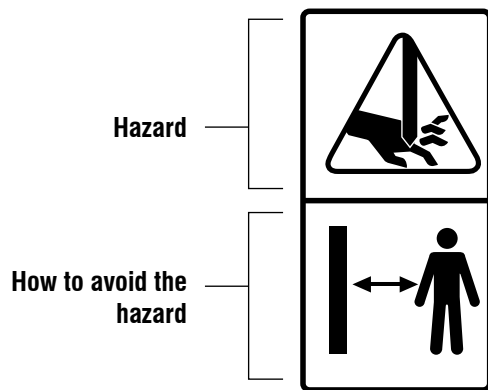

Think SAFETY! Work SAFELY!

3.1 Safety Sign Locations

Numbers correspond with the *Safety Sign Explanations on page 15.*

Safety

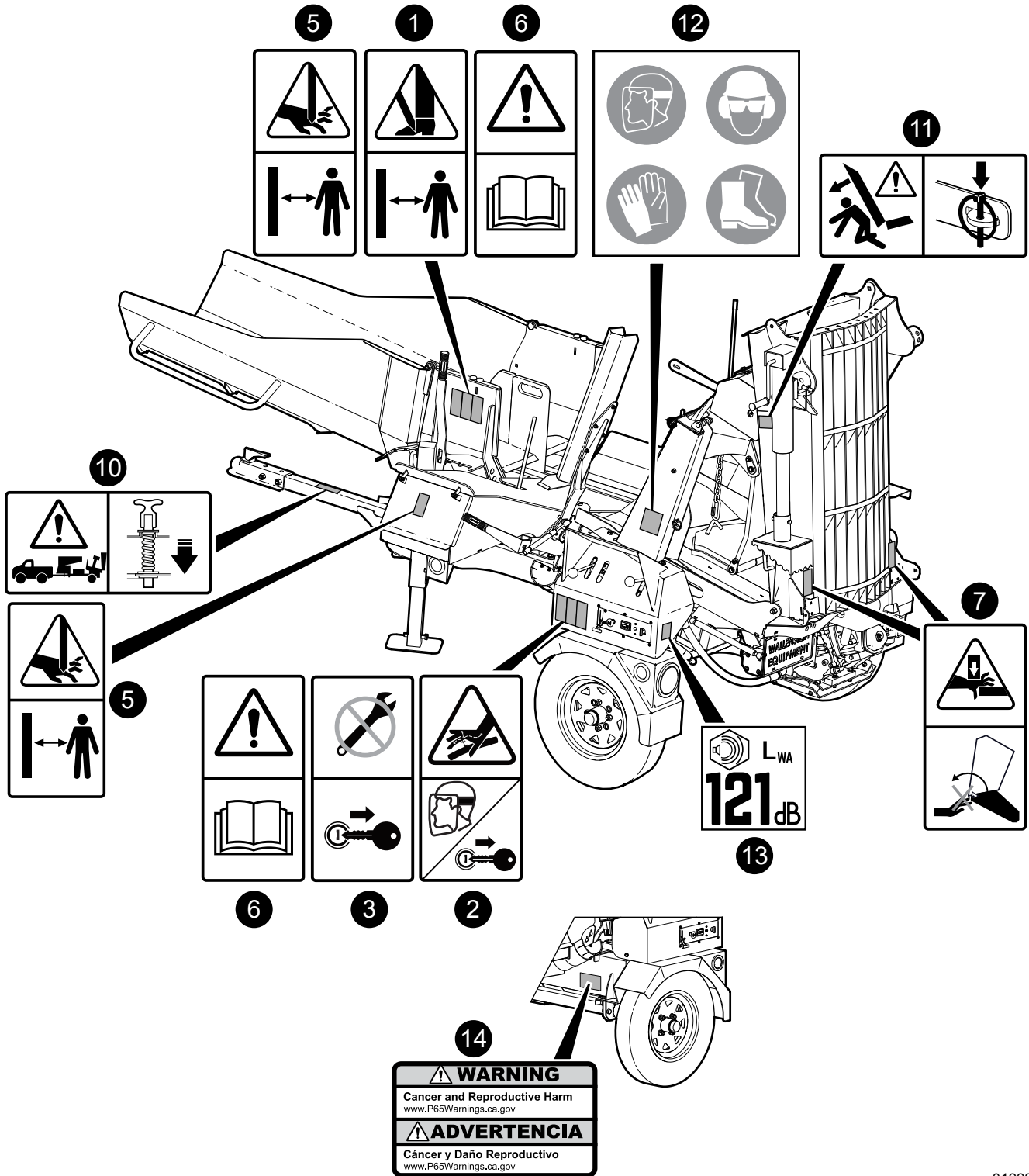
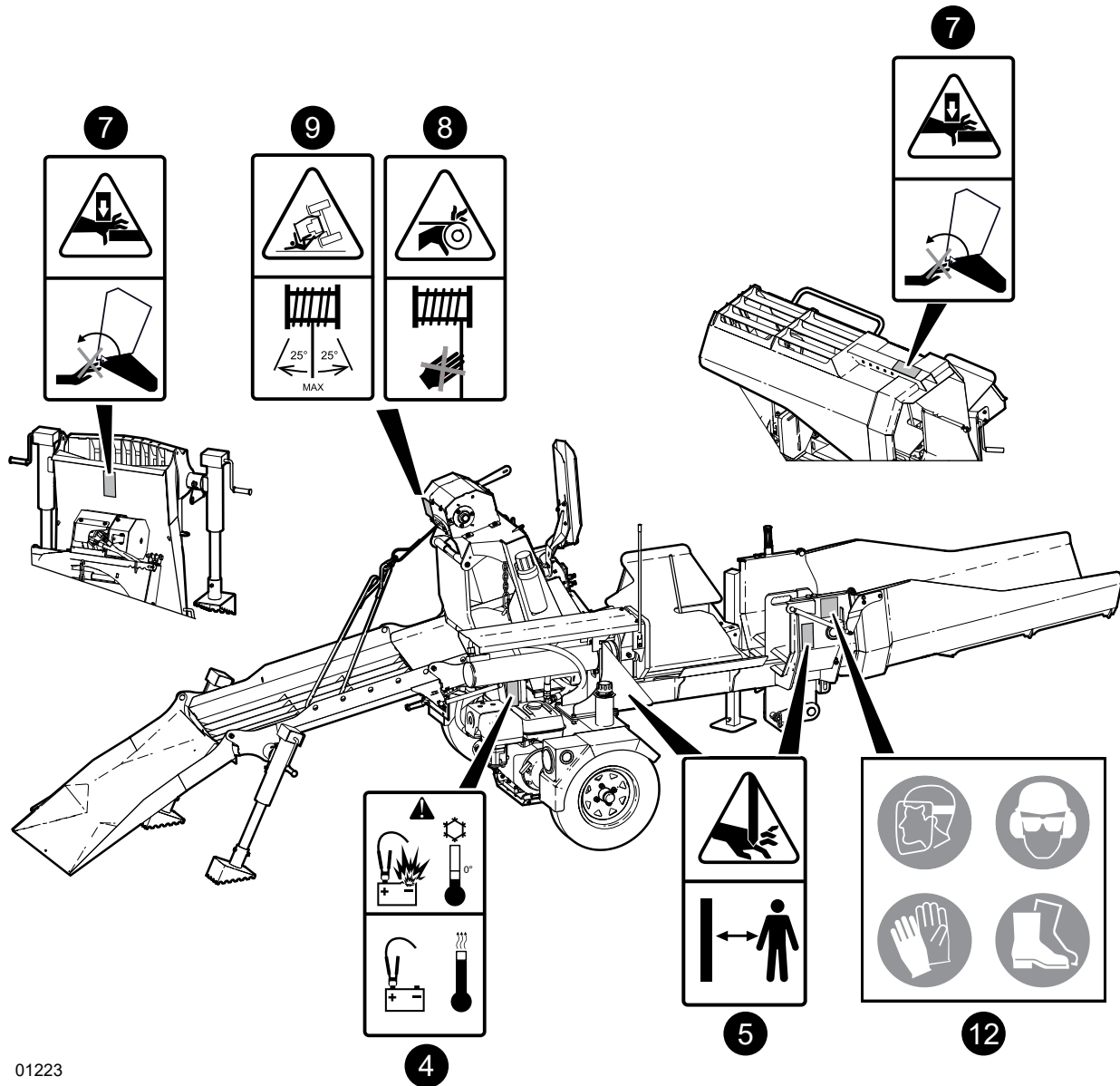

Fig. 3—Safety sign locations—LH side

01222



01223

Fig. 4—Safety sign locations—RH side

3.2 Safety Sign Explanations

1. Warning!

Falling objects hazard in this area.

Keep feet away from falling split wood.

Always wear steel-toed footwear while the machine is in operation. Serious personal injury could result.

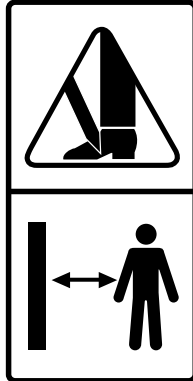

2. Warning!

High-pressure injection hazard

Hydraulic fluid is under pressure. In the event of a leak, turn off the machine. Do not use your bare hands to check for leaks. Use a piece of cardboard, wood, or plastic to locate the leak. Wear the proper hand and eye protection when searching for a high-pressure hydraulic leak.

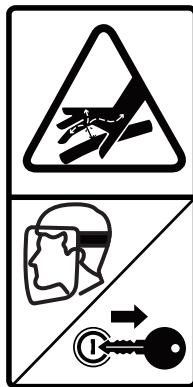

3. Warning!

Risk of serious injury or death if the engine is on during service or maintenance.

Turn off the engine and remove the key before maintenance or service.

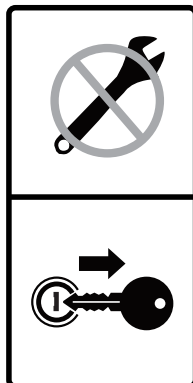

4. Warning!

Risk of explosion.

Charging a frozen battery can cause it to explode.

Warm the battery to 60 °F (16 °C) before charging it.

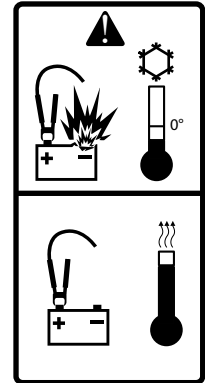

5. Warning!

Crush, cut, or sever hazard.

There is a risk of hands being crushed, cut, or fingers severed in this area.

Keep hands clear of all moving parts.



6. Caution!

Read the Operator's Manual

Read ALL operating instructions and safety information in the manual. Learn the meaning of ALL safety signs on the machine.

The best safety feature is an informed operator.

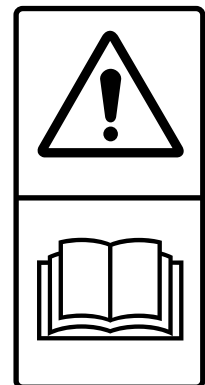

7. Caution!

Pinch point hazard

When folding or unfolding a chute, be aware of the pinch points. Use the handle on the side of the chute.

Keep hands clear to avoid injury.

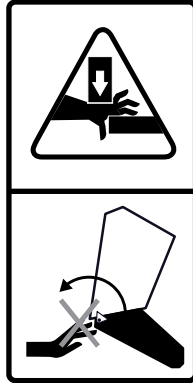

8. Caution!

Winch entanglement hazard

When using the winch, keep hands clear of the winch rope to avoid injury.

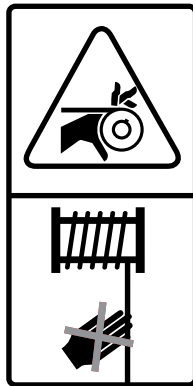

9. Warning!

Tip over hazard

When using the winch, do not exceed a $\pm 25^\circ$ pull angle from the centerline of the machine.

Use snatch blocks when winching at angles greater than 25° .

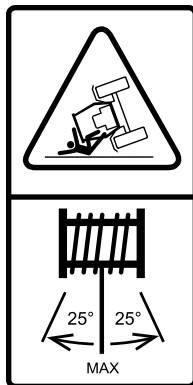

10. Caution!

Risk of unexpected machine movement.

When moving the firewood processor, make sure that the pivot tongue lock pin is fully engaged.

Personal injury or machine damage could result.

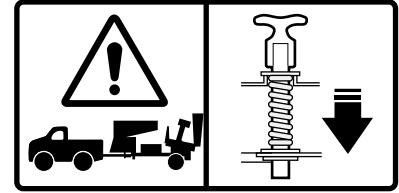

11. Caution!

Risk of unexpected machine movement.

Make sure the latch is secure during transport.

Personal injury or machine damage could result.

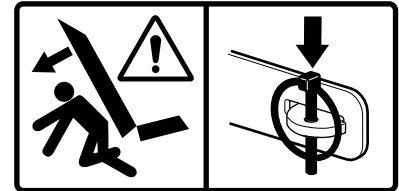

12. Warning!

Always wear the appropriate PPE during operation:

- A hard hat.
- Heavy gloves.
- Hearing protection.
- Protective footwear with steel toes and slip resistant soles.
- Protective glasses, goggles, or a face shield.



13. Caution!

Noise level hazard

The noise declaration decal indicates the sound power (L_{WA}) emitted by the machine when it is operating. For this machine, the noise level can be up to 87 decibels at close range.

Noise exposure over 85 dB on a long-term basis can cause severe hearing loss. Exposure over 90 dB on a long-term basis may cause permanent, total hearing loss.



14. Warning!

Risk of cancer and reproductive harm

The machine materials contain chemicals or machine operation may produce gases or dust that are identified by the state of California as causes of cancer, birth defects, or other reproductive harm.

This warning is required by the state of California, USA to comply with Proposition 65: the Safe Drinking Water and Toxic Enforcement Act of 1986.



3.3 Replace Damaged or Missing Safety Signs

- Always replace safety signs that are missing or have become illegible. Replacement safety signs are available from your authorized distributor, dealer parts department, or Wallenstein Equipment.
- Keep the safety signs clean and legible at all times.
- Parts replaced that had a safety sign (decal) on them must also have the safety sign replaced.

Requirements

- The installation area must be clean and dry.
- The application surface must be clean and free of grease or oil.
- The ambient temperature must be above 50 °F (10 °C).
- A squeegee, plastic bank card, or similar tool is required to smooth out the decal.

Procedure



Determine the exact position for the decal before removing the backing paper. If possible, align the decal with an edge on the machine.

1. Peel the decal off the backing paper.
2. Position the decal above the location where it is being applied to the machine.
3. Starting at one edge, carefully press the center of the exposed sticky-backing in place, smoothing it out as you work from one side to the other.
4. Use an appropriate tool to smooth out the decal, working from one end to the other.
Small air pockets can be pierced with a pin and smoothed out using a piece of the decal backing paper.

4. Familiarization

A Wallenstein 800 Series firewood processor is designed to process logs into split firewood. Winch a log up the lead-in chute, through the log-loader chute, to the log-length guide. Use a chain saw to cut the log to the required length. The cut log rolls into the splitting cradle. Activate the push block to move it forward and split the log. The split log pushes previously split logs up the splitter chute and out of the machine. Power to operate the machine is provided by the gas engine and the hydraulic pump.

4.1 New Operator

! WARNING!

Make sure all operators understand how to place the machine in a safe condition before performing any service, maintenance, or storage preparation. For instructions, see *Safe Condition on page 9*.

It is the responsibility of the owner and the operator to read this manual, and to train all other operators before they work with the machine. Follow all safety instructions.

Untrained operators are not qualified to use the machine. They can endanger themselves and others or damage property.

4.2 Training

Each operator must be trained in the correct operating procedures before using the machine. The *Sign-Off Form on page 10* can be used to keep a training record.

1. Review control locations, functions, and movement directions.
2. Move the machine to a large open area and allow the new operator to become familiar with control functions and machine responses.
3. When the new operator is familiar and comfortable with the machine, they can proceed with the work.

4.3 Work Site Familiarization

It is the responsibility of the operator to be thoroughly familiar with the work site before starting work. Avoid unsafe situations and make every effort to prevent accidents.

For more information, see *Create a Safe Work Area on page 11*.

When you set up a work site, consider the following things:

- Avoid close or cramped workspaces. Make sure there is enough space and clearance for the machine and winching.
- Position the machine so prevailing winds blow engine exhaust fumes away from operator's location.
- Choose flat, level ground, and make sure the machine is level before operating it.
- Avoid muddy or soft ground where the jack stand and supports will sink. If soft ground is unavoidable, place boards or plates under the jack stand and supports to increase the surface area.

4.4 Operator Orientation

IMPORTANT! When describing controls throughout this manual, the directions for left hand (LH), right hand (RH), backward, and forward are determined when standing at the operator controls facing the direction of forward machine travel.

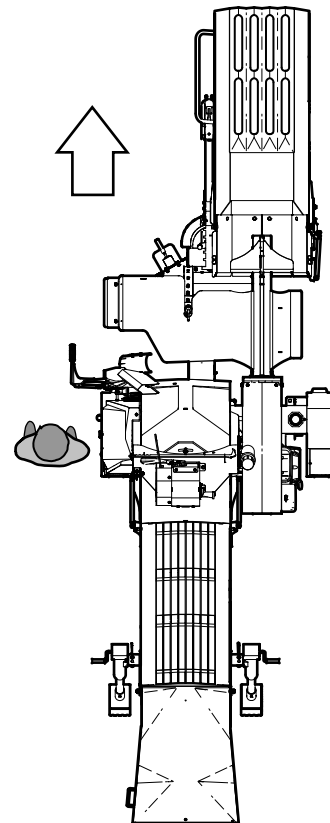
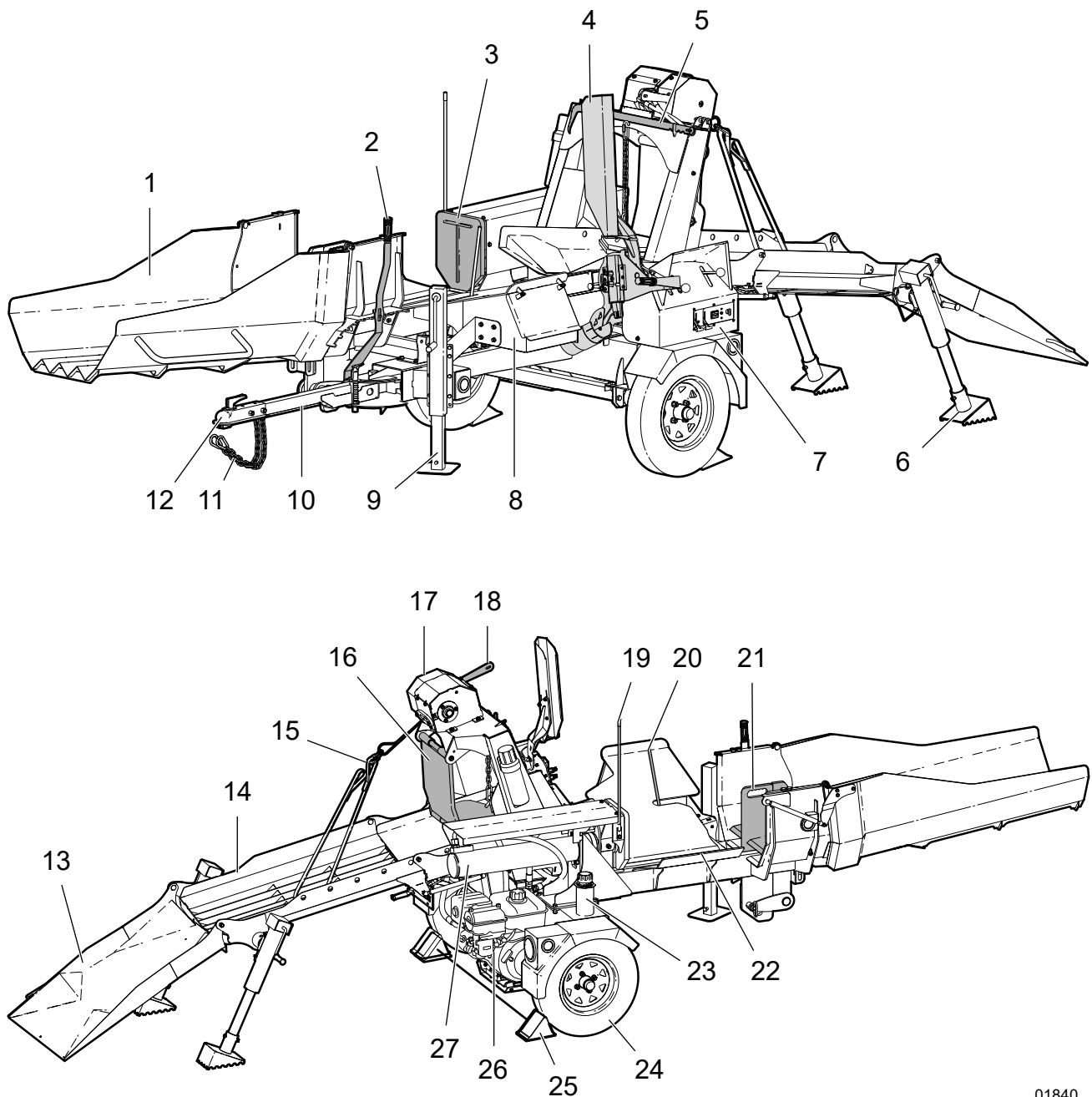

Fig. 5—Direction of forward machine travel

4.5 Machine Components

The WP845 model is shown, however both 800 Series models have the same components.



01840

Fig. 6—Machine components

- | | | |
|----------------------------------|-------------------------|---|
| 1. Splitter chute | 10. Pivot tongue | 19. Push-block locator |
| 2. Wedge-height adjustment lever | 11. Safety chains | 20. Log-length guide |
| 3. Push block | 12. Ball-hitch | 21. Splitting wedge |
| 4. Chain-saw holder | 13. Lead-in chute | 22. Splitting cradle |
| 5. Hookaroon | 14. Log-loader chute | 23. Hydraulic fluid reservoir |
| 6. Bracing jacks | 15. Winch rope and hook | 24. Wheels –5.30-12 LRC USA Trail 4on4" |
| 7. Operator control panel | 16. Log stabilizer | 25. Wheel chocks |
| 8. Toolbox | 17. Winch | 26. Vanguard® engine |
| 9. Trailer jack | 18. Winch gear lever | 27. Hydraulic cylinder (push block) |

5. Controls

WARNING!

Do not operate the machine until you are thoroughly familiar with the position and function of the various controls. Read the operator's manual thoroughly. Your safety is involved!

W065

5.1 Engine Controls

CAUTION!

Before starting the engine, review the safety, operating, and maintenance instructions in the engine manual.

W019

5.1.1 Engine Control Panel

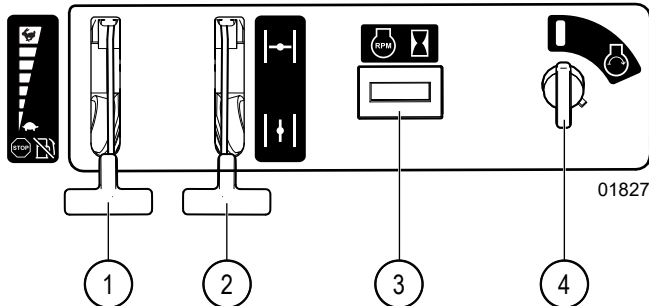

01827

Fig. 7—Engine controls

- | | |
|---------------------|-----------------------|
| 1. Throttle control | 3. Hour and rpm meter |
| 2. Choke control | 4. Ignition switch |



Fast
Engine speed is fast.



Slow
Engine speed is slow.



STOP
The engine is stopped.



Fuel shut-off closed

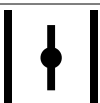

Choke open
Engine warm.

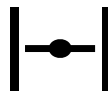

Choke closed
Engine start.

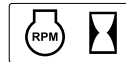

RPM and hours

The display shows the engine rpm or hours of operation. For more information, see *Hour Meter and RPM Display*.



Run

The ignition switch is not in use. The engine may be on or off when the ignition switch is in the **Run** position.



Start

Turn the keyed ignition switch clockwise to this position to start the engine. When the engine starts, release the key. The ignition switch automatically rotates counterclockwise to the **Run** position.

Before starting the engine, see *Engine Operation* on page 27.

5.1.2 Hour Meter and RPM Display

While the engine is operating, the hour meter displays the engine revolutions per minute (rpm). When the engine is off, the hour meter displays the total number of hours the engine has operated since it was new. The hour meter has an internal battery.

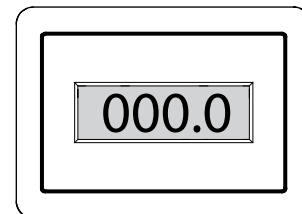

01311

Fig. 8—Hour meter

5.1.3 Starter-cord Handle



The rewind-start is an alternative to the ignition switch. The primary way to start the engine is to turn the ignition switch.

The engine includes a rewind-start. Grip the starter-cord handle to pull the starter cord and start the engine.

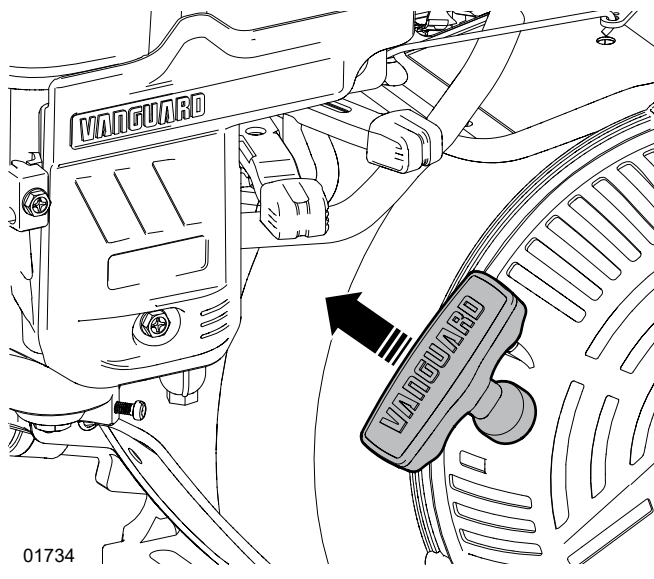

Fig. 9—Starter-cord handle

5.2 Hydraulic Controls

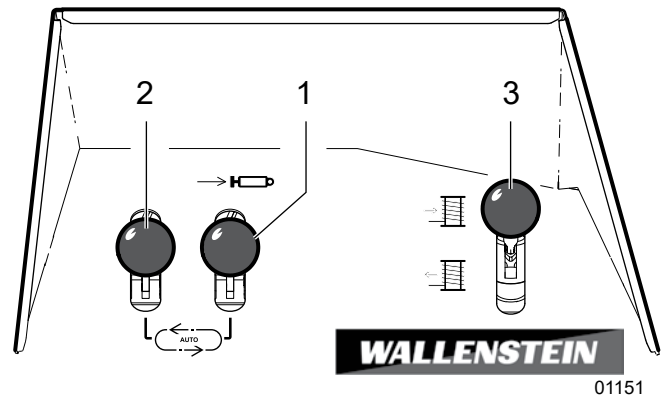

Fig. 10—Hydraulic controls

1. Splitter cylinder extend
2. Splitter cylinder retract
3. Hydraulic winch control

5.2.1 Splitter Cylinder Controls

Splitter cylinder extend (1)—extends the cylinder (the first half of the cylinder auto cycle).

- Push the lever down (into detent) to extend the cylinder. When the cylinder is fully extended, the lever moves up to the neutral position and stops the cylinder.
- Push the lever up to manually retract the cylinder.

Splitter cylinder retract (2)—retracts the cylinder (the second half of the cylinder auto cycle).

- Push the lever down (into detent) to retract the cylinder. When the cylinder is fully retracted, the lever moves up to the neutral position and stops the cylinder.
- The lever has no function in the full up position.

5.2.2 Auto Cycle

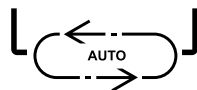

Push the two splitter cylinder levers down (to the detent position) to automatically cycle the splitter cylinder.

In **Auto Cycle**, the machine does the following:

1. The splitter cylinder extends to split the log.
2. When the cylinder is at the end of its stroke, the splitter cylinder extend lever moves up to the neutral position (out of detent).
3. The cylinder begins to retract.
4. When the cylinder is fully retracted, the splitter cylinder retract lever moves up to the neutral position (out of detent) and the cylinder stops.

5.2.3 Hydraulic Winch Control



Stay clear of the winch rope while winching. Injury from entanglement or rope burn could occur!

W056

The hydraulic winch control (3) lever is on the RH side of the operator control panel.

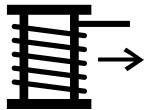

Unwind

Pull and hold the lever up to unwind the winch rope. Use this control intermittently and pull the rope out by hand to prevent it from getting tangled inside the winch housing.

Release the lever to stop. The lever moves to the neutral position.

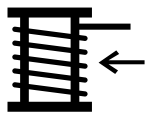

Wind

Push and hold the lever down to wind the winch rope into the winch.

Release the lever to stop. The lever moves to the neutral position.

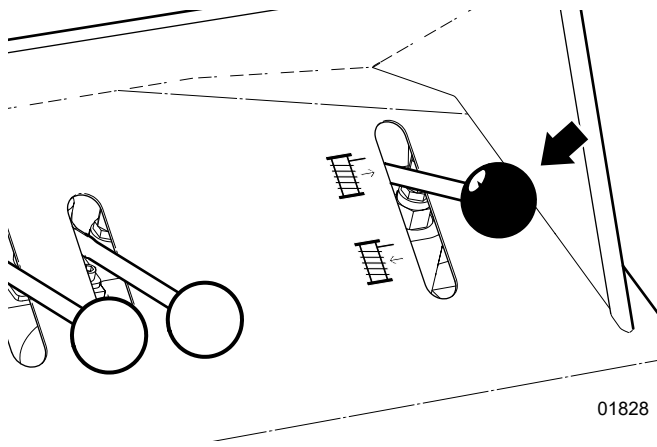
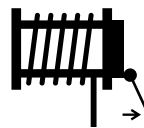

Fig. 11 –Hydraulic winch control lever

5.2.4 Winch Gear Lever

The winch gear lever controls the winch drive system.



Powered

Pull the lever to the LH side (toward the operator) to engage the winch gear with the hydraulic motor.

The hydraulic winch control is enabled and controls the winch operation.

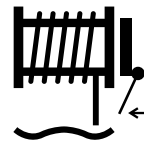

Freewheel

Push the lever to the RH side (away from the operator) to disengage the winch gear from the hydraulic motor.

Pull out the winch rope by hand. The winch spool turns freely, and the hydraulic winch control is disabled.

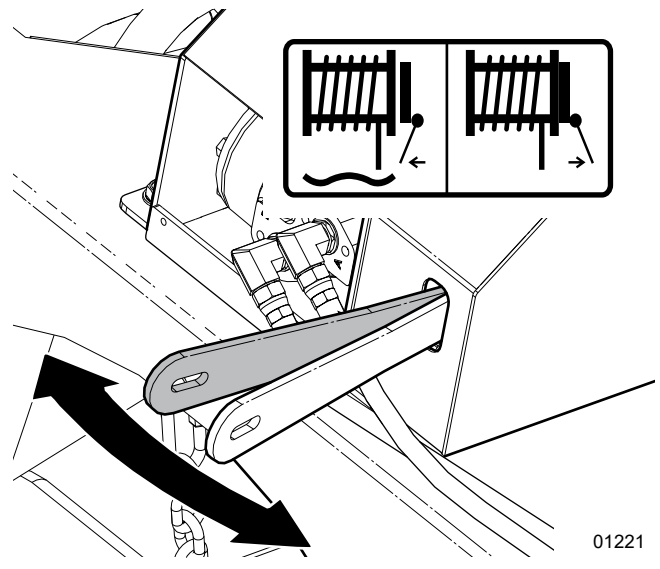
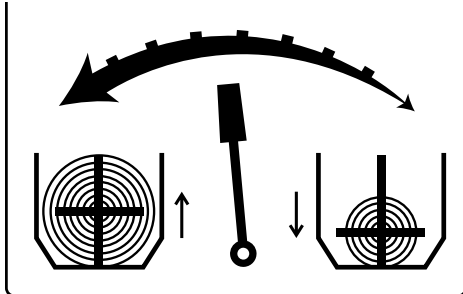

Fig. 12 –Winch gear lever

5.3 Splitting-Wedge Height Adjustment Lever

The lever adjusts the height of the splitting wedge to align it with the log. For instructions, see *Set the Splitting-Wedge Height on page 37*.



High
Move the lever toward the **High** setting to raise the splitting wedge.

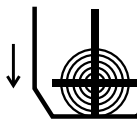

Low
Move the lever toward the **Low** setting to lower the splitting wedge.

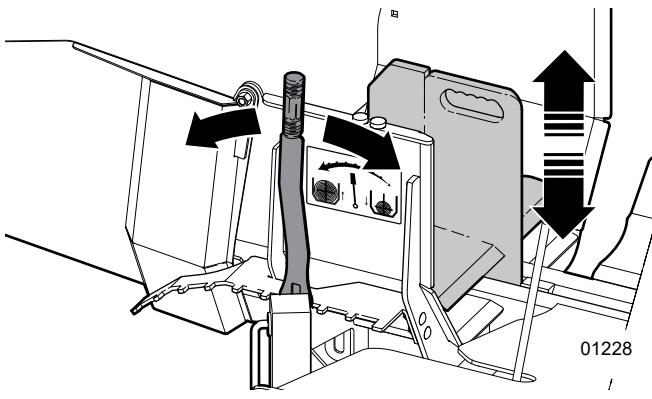

Fig. 13—Splitting-wedge height adjustment lever

5.4 Log-length Guide

The log-length guide is located on the LH side of the splitting cradle. The operator can select the desired log length. For instructions, see *Set the Log-length Guide on page 37*.

The log-length guide can be set to one of the following lengths:

- 14 in (37 cm)
- 16 in (41 cm)
- 18 in (46 cm)
- 20 in (51 cm)
- 22 in (56 cm)
- 24 in (61 cm)

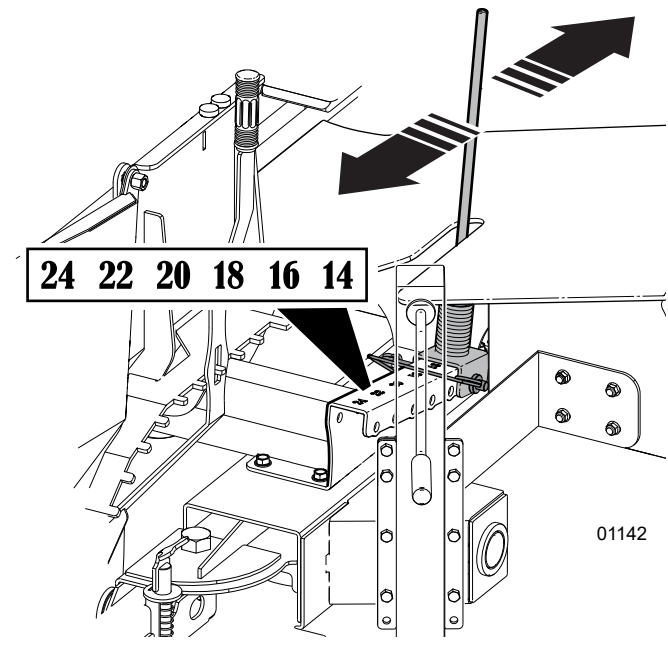

Fig. 14—Log-length guide

5.5 Splitter Chute Height Adjustment

Use the adjustable sliding bracket to set the splitter chute height. The front end of the splitter chute can be set to a maximum height of 54" (1.37 m).

This feature provides a method to load split wood directly onto a conveyor or into a high-sided dump trailer.

For instructions, see *Set the Splitter Chute Height* on page 36.

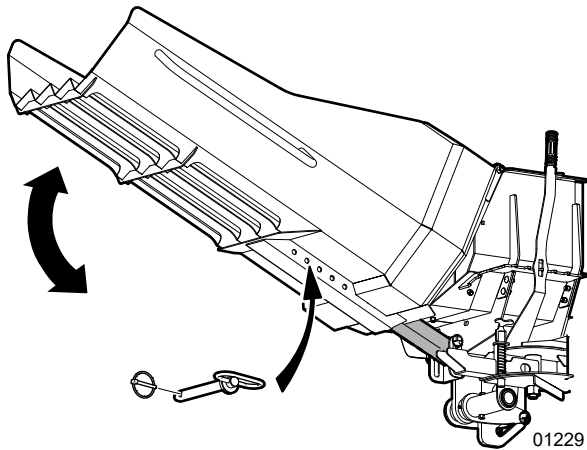

Fig. 15—Splitter chute height adjustment

6. Operating Instructions

Read and understand the operating instructions before using the machine.

6.1 Operating Safety

WARNING!

Wear the personal protective equipment (PPE) that is required to complete the work safely.

This includes, but is not limited to a hard hat, hearing protection, a face shield, protective footwear, a respirator, and heavy gloves.

W101

WARNING!

Always use the machine outdoors and park the machine in a position where the prevailing winds blow the engine exhaust away from the operator. Exhaust from the engine contains carbon monoxide (CO) that can accumulate to a dangerous level, even in an area with good air flow.

W006

The operator is responsible to be familiar with and follow all operating and safety procedures. Read and understand all the safety information in this manual before operating the firewood processor.

- Read the chain saw and engine manufacturer's manuals and follow all safety instructions.
- Park the machine in a clear location on dry, level ground. Do not operate the machine on a hillside or area that is cluttered, wet, muddy, or icy to prevent slips and trips.
- Keep the work area clean and free of debris.
- Never operate an engine inside a closed building. The exhaust fumes may cause asphyxiation.
- De-limb logs before loading them.
- Do not try to process more than one log at a time. The extra log can move unexpectedly and cause injury.
- Never reach into the splitting area with your hands while the machine is operating. Use a hookaroon or peavey to reposition cut logs in the splitting area.
- Do not try to split logs across the grain. Logs can burst or splinter, and then fly out of the machine causing injury.
- Use care when pulling logs from a pile. The logs can roll when attaching a rope or during winching. Use a hookaroon or peavey to handle logs for positioning.

- Do not move or transport the machine with the engine running.
- Never stand, sit, or climb on any part of the machine while the engine is running.
- **Never operate the machine alone!** Always have at least two fully trained people present:
 - It is recommended that there be one operator and one spotter present during machine operation. Both the operator and spotter must be completely familiar with all the machine safety, controls, and operating functions.
 - **The operator must be in control of the machine at all times. The spotter must remain outside of the hazard zone, while the machine is in operation.**
- Keep bystanders at least 10 ft (3 m) from the stacking zone. Mark the safe zone with safety cones.
- Before starting the machine, close and secure all guards, shields, deflectors, and covers. If a guard, shield, or cover is removed, replace it.
- Turn off the engine before leaving the machine unattended.

6.2 Pre-start Checklist



WARNING!

Before you start service or maintenance work:

- Set the machine to a safe condition.
- Wait for the machine to cool down. Engine components and fluids may be hot enough to cause burns.
- Read and understand all of the service and maintenance safety information.

W041

Complete the following before you start the machine the first time and every time thereafter:

Items to Complete	✓
Review and follow the <i>Operating Safety</i> on page 25.	
Check the engine oil, fuel, and hydraulic fluid levels. If required, add engine oil, fuel, or hydraulic fluid.	
Check that the engine spark plug, muffler, fuel cap, and air cleaner cover are in place and secure.	
Make sure the winch is in good, working condition. Repair or replace the winch, as required.	
Make sure the winch rope is in good condition. Replace the rope if it is cut, knotted, worn, or has any broken strands.	
Make sure the winch strap (or choker chain) is in good condition. Replace the strap if it is torn or damaged.	
Make sure the machine is lubricated, as specified in the <i>Maintenance Schedule</i> on page 58.	
Check the hydraulic system for leaks. Use a safe method to inspect for leaks. Tighten fittings or replace components, as required. For more information, see <i>Hydraulic Fitting Torque</i> on page 66.	
Check the machine for entangled material. Remove any twine, wire, or other material that has become entangled.	
Make sure the wedge and push block are in good, working condition. Inspect for damaged or broken components and excessive wear. Lubricate, repair, or replace components, as required.	
Check that all guards, shields, and covers are installed, secure, and in good condition. Replace and secure, as required.	
Check that all the fasteners are installed and tightened to the correct torque. For more information, see <i>Common Bolt Torque</i> on page 65.	
Make sure the operator and spotter are wearing the required PPE (including hard hat, safety eye wear, safety footwear, safety vest, hearing protection, and work gloves). The PPE must be in good repair.	
Make sure the operator and spotter are not wearing loose-fitting clothing or jewelry, and long hair is tied up.	
Make sure there are no bystanders inside the work zone and the spotter is outside the hazard zone. For zone definitions, see <i>Create a Safe Work Area</i> on page 11.	

6.3 Machine Break-In

Although there are no operational restrictions on the firewood processor when used for the first time, the following process is recommended:

Before Initial Startup

1. Read and understand all safety information in this manual, the engine manufacturer's manual, and the chain saw manufacturer's manual.
2. Review the *Machine Components* on page 19.
3. Review the operation and function of the *Controls* on page 20.
4. Complete the *Pre-start Checklist*.

After 5 Hours of Operation

Complete each of the following:

- Check that all the fasteners are installed and tightened to the correct torque. For more information, see *Common Bolt Torque* on page 65.
- Check the hydraulic system for leaks. Use a safe method to inspect for leaks. Tighten fittings or replace components, as required. For more information, see *Hydraulic Fitting Torque* on page 66.
- Check the engine oil, fuel, and hydraulic fluid levels. If required, add engine oil, fuel, or hydraulic fluid.
- Change the engine oil. For instructions, see the engine manufacturer's manual.
- Check the condition of the winch. Repair, as required.
- Check the condition of the winch rope. Replace the rope if it is cut, knotted, worn, or has any broken strands.
- Check the machine for entangled material. Remove any twine, wire, or other material that has become entangled.
- Lubricate all grease fittings.

After 20 Hours of Operation

1. Complete each of the following:
 - Check that all the fasteners are installed and tightened to the correct torque.
 - Check the hydraulic system for leaks. Use a safe method to inspect for leaks. Tighten fittings or replace components, as required.
 - Check the engine oil, fuel, and hydraulic fluid levels. If required, add engine oil, fuel, or hydraulic fluid.
 - Check the condition of the winch. Repair the winch, as required.
 - Check the condition of the winch rope. Replace the rope if it is cut, knotted, worn, or has any broken strands.

- Check the machine for entangled material. Remove any twine, wire, or other material that has become entangled.
 - Lubricate all grease points. For more information, see *Grease Points on page 59*.
2. Continue with the regular *Maintenance Schedule on page 58*.

6.4 Engine Operation

CAUTION!

Before starting the engine, review the safety, operating, and maintenance instructions in the engine manual.

W019

6.4.1 Engine Safety

WARNING!

Never operate the engine indoors. Park the machine outdoors in a position where the prevailing winds blow the exhaust away from you.

Engine exhaust contains carbon monoxide (CO) that can quickly accumulate to a dangerous level. Carbon monoxide can cause illness, unconsciousness, or death.

W072

- Remove the wire from the spark plug before servicing the engine or equipment to prevent accidental starting.
 - Keep cylinder fins and governor parts free of grass and other debris that can affect the engine speed.
 - Examine the muffler periodically to make sure it is functioning effectively. Repair or replace a worn or leaking muffler.
 - Use fresh gasoline (less than three months old). Stale fuel creates insoluble solids (deposits) that clog the carburetor and cause leaks.
 - Before storage, replace fuel that contains ethanol with an alkylate or appropriate engineered fuel to prevent the buildup of deposits.
 - Check fuel lines and fittings frequently for cracks or leaks. Replace damaged fuel lines or fittings, as required.
 - Store fuel well away from all wood material.
 - Do not operate a gas engine in an enclosed area. Exhaust gases contain carbon monoxide (an odorless and deadly gas).
 - Do not place hands or feet near moving or rotating parts.
- Do not choke the carburetor to stop the engine. Whenever possible, gradually reduce the engine speed before stopping.
 - Do not tamper with governor springs, governor links or other parts that may increase the governed speed. Engine speed is selected by the original equipment manufacturer.
 - Do not check for spark with the spark plug or spark plug wire removed.
 - Do not attempt to start the engine with the spark plug removed. If the engine floods, set the choke control to **Open**, set the throttle control to **Fast**, and then try starting the engine again.
 - Do not strike the flywheel with a hard object or metal tool. This may cause the flywheel to shatter during operation. Use the correct tools to service the engine.
 - Do not operate the engine without a muffler or heat shield. Inspect them periodically and replace them if they are damaged.
 - Do not operate the engine with an accumulation of wood chips, dirt, or other combustible materials in the muffler area.
 - Do not use the engine on any forest covered, brush covered, or grass covered unimproved land unless a spark arrester is installed on the muffler. The arrester must be maintained in effective working order by the operator. In the state of California, the previous statement is required by law (Section 4442 of the California Public Resources Code). Other states may have similar laws. Federal laws apply on federal land.
 - Do not touch a hot muffler, cylinder, or fins. Contact may cause burns.
 - Do not run the engine with the air cleaner or air cleaner cover removed. Doing this can damage the engine.

6.4.2 Battery Safety

! WARNING!

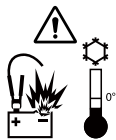

Charging a frozen battery can cause it to explode. Warm the battery to 60 °F (16 °C) before charging.

W030

! CAUTION!

Risk of explosion or fire! Do not let metal objects come in contact with the battery terminals. Arcing can cause a fire or explosion. Cover terminals if working near batteries.

W021

! CAUTION!

Risk of burns! Battery electrolyte is extremely corrosive and poisonous. Contact with the eyes, skin or clothing can result in severe burns or other serious personal injury. If contact occurs seek medical attention immediately. Handle batteries carefully.

W029

! CAUTION!

Battery posts, terminals and related accessories contain lead and lead compounds. These chemicals are known to cause cancer and birth defects or other reproductive harm. Wash hands after handling.

W031

- Wear gloves and safety glasses or face shield when working on or near batteries.
- Use a battery carrier to lift the battery or place hands at opposite corners to avoid spilling acid through the vents.
- Avoid contact with battery electrolyte:
 - **External Contact:** Flush immediately with water.
 - **Eye Contact:** Flush with water for 15 minutes. Get prompt medical attention. Clean up any spilled electrolyte immediately.
- Keep all sparks and flames away from batteries. Gases given off by electrolyte is explosive.
- To avoid injury from spark or short circuit, disconnect battery ground cable before servicing any part of the electrical system.

6.4.3 Check the Engine Fuel Level

! WARNING!

Fuel and vapors are extremely flammable and explosive. Fire or explosion can cause severe burns, bodily harm, or death. Keep fuel away from sparks, open flame, pilot lights, heat, and any other source of ignition.

! CAUTION!

Fuel vapors are very toxic. Breathing fuel vapors can cause irritation, illness, or unconsciousness. Check the fuel level outdoors or in a well-ventilated area.

Check the engine fuel level before each use.

Starting work with a full tank helps to eliminate or reduce operating interruptions for refueling. Avoid running the tank dry.

1. Park the machine on level ground.
2. Stop the machine.
For instructions, see *Stop the Machine on page 32*.
3. Wait a minimum of five minutes for the engine to cool.
4. Turn the fuel cap counterclockwise to remove it.
5. Check the fuel level. The fuel tank is full when the fuel level is visible 1/2 inch (12 mm) below the filler neck. There must be room for fuel expansion.
6. Do one of the following:
 - If there is enough fuel in the tank, install and secure the fuel cap to prevent spillage.
 - If there is not enough fuel in the tank, add fuel. For instructions, see *Add Fuel to the Engine on page 29*.

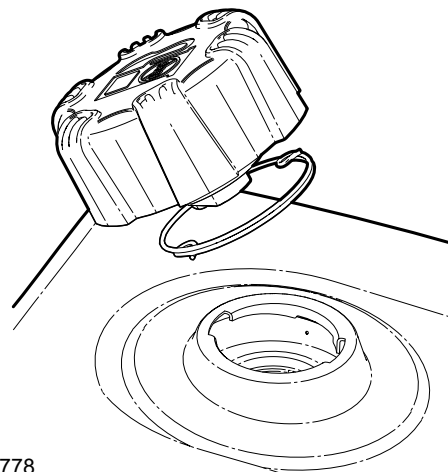

01778

Fig. 16–Fuel cap

6.4.4 Add Fuel to the Engine

WARNING!



Never smoke or vape while working with fuel. Fuel vapors can explode causing injury or death. Keep sparks, flames, and hot components away.

W027

CAUTION!

Fuel vapors are very toxic. Breathing fuel vapors can cause irritation, illness, or unconsciousness. Fill the fuel tank outdoors or in a well-ventilated area.

The engine requires clean, fresh, unleaded gasoline with a pump octane rating of 87 or higher (research octane number [RON] of 91 or higher). Gasoline with up to 10% ethanol (gasohol) is acceptable. For more information, see *Engine Fuel* on page 57.

For information about use at high altitudes, see the engine manufacturer's manual.

Fuel tank capacity: **1.26 US gal (5.74 L)**.

1. Stop the machine.
For instructions, see *Stop the Machine* on page 32.
2. Wait a minimum of five minutes for the engine to cool.
3. Turn the fuel cap counterclockwise to remove it.
4. Add the correct type and amount of fuel to the tank until the fuel level is visible 1/2 inch (12 mm) below the filler neck. Leave room for expansion. **Do not overfill the tank.**
5. If fuel is spilled, carefully clean it up and wait until the fuel dries before starting the engine.
6. Install and secure the fuel cap to prevent spillage.

6.4.5 Check the Engine Oil Level

IMPORTANT! For more information about engine oil, see the engine manufacturer's manual and *Engine Oil* on page 57.

Operating the engine with a low oil level can cause engine damage that is not covered by the warranty.



The engine must be in a level position for the dipstick to show the oil level correctly.

Check the engine oil level before each use.

1. Park the machine on level ground.
2. Set the machine to a safe condition.
For instructions, see *Safe Condition* on page 9.
3. Pull out the oil-level dipstick and wipe it clean.
4. Fully reinsert the oil-level dipstick.
5. Pull out the oil-level dipstick and check the oil level.
The oil level is correct when oil is visible on the dipstick from the end to the full (upper) mark.
6. Do one of the following:
 - If the oil level is correct, continue with Step 7.
 - If the oil level is low, add oil until the oil-level is at the full (upper) mark. For instructions, see *Add Oil to the Engine* on page 30.
7. Insert and secure the oil-level dipstick.

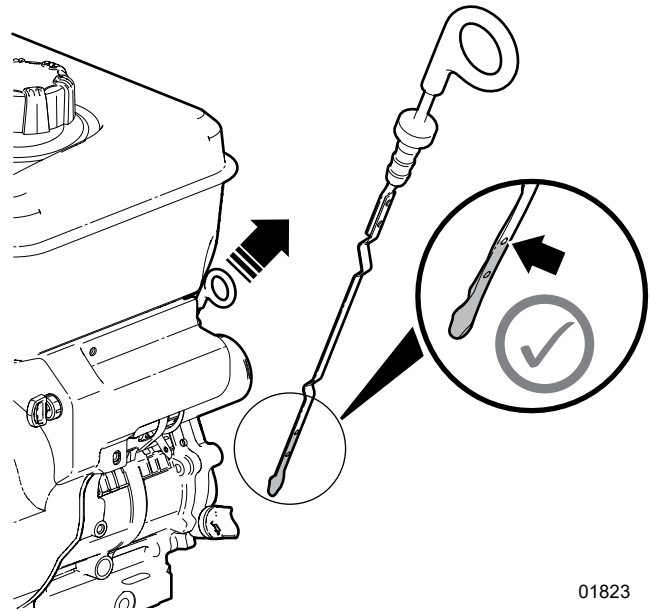

01823

Fig. 17—Check the engine oil level

6.4.6 Add Oil to the Engine

IMPORTANT! For more information about engine oil, see the engine manufacturer's manual and *Engine Oil* on page 57.

The engine has three oil-fill locations. The two most accessible locations are shown in the following image. The third location is on the opposite side of the engine, below the dipstick.

1. Check the engine oil level to make sure that the oil level is low. For instructions, see *Check the Engine Oil Level* on page 29.
2. Turn an oil-fill cap counterclockwise to remove it.
3. Use a clean funnel to slowly add the correct type and amount of oil. **Do not overfill.**
4. Wait a minimum of one minute.
5. Remove the funnel, and then check the engine oil level.
6. Install and secure the oil-fill cap to prevent spillage.

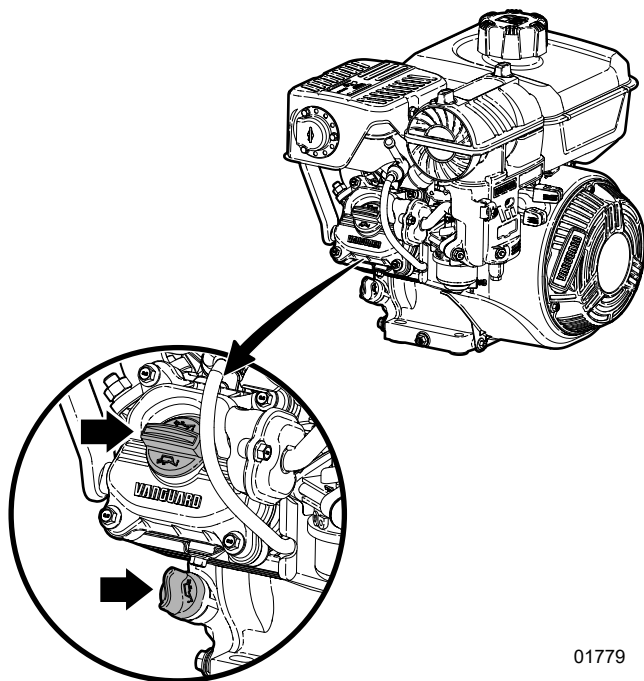

Fig. 18—Engine oil-fill locations

6.5 Hydraulic System Operation

A hydraulic system is a closed-loop system that uses pressurized fluid to provide power to devices (for example; the winch motor and the push block cylinder).

6.5.1 Hydraulic System Safety

- Make sure that all hydraulic system components are kept clean and in good condition.
- Relieve pressure on the hydraulic system before working with it. The hydraulic system operates under extremely high pressure.
- Before applying pressure to the hydraulic system, make sure that all the connections are tight, and the hoses and fittings are not damaged.
- Immediately replace any hydraulic hose that shows signs of swelling, wear, leaks, or damage. A swollen, worn, damaged, or leaking hose can burst and cause a hazardous and unsafe condition.
- High-pressure hydraulic oil leaks:
 - Do not use your hand to check for hydraulic oil leaks. Hydraulic fluid escaping under pressure can penetrate the skin causing serious injury or death. Use a piece of cardboard or wood to check for leaks.
 - Wear the correct hand and eye protection when searching for a high-pressure hydraulic leak.
 - Seek medical attention immediately if injured by a concentrated high-pressure stream of hydraulic fluid. Serious infection or toxic reaction can develop after hydraulic fluid pierces the skin's surface.
- Do not attempt any makeshift repairs to the hydraulic lines, fittings, or hoses. Do not use tape, clamps, or cements to attempt a repair. Doing so can cause sudden failure and create a hazardous and unsafe condition.
- Do not bend or strike high-pressure lines, tubes, or hoses, or reinstall them in a bent or damaged condition.
- Make sure that hydraulic hoses are routed to avoid chafing.
- Never adjust a pressure relief valve or other pressure-limiting device to a higher pressure than specified.

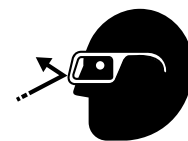

6.5.2 Check the Hydraulic Fluid Level

IMPORTANT! Do not operate the machine if the hydraulic fluid level is low. Damage to the pump and other components can occur.

Do not fill the hydraulic-fluid reservoir higher than the sight glass.

IMPORTANT! Inspect the hydraulic fluid quality every 50 hours. If the fluid is dirty or smells burnt, replace it.

IMPORTANT! Be aware of high fluid temperatures. Temperatures higher than 180 °F (82 °C) could cause seal damage and degrade the hydraulic fluid quality.

Check the hydraulic fluid level daily, after changing the filter, and after servicing hydraulic components. The fluid-level sight glass is on the side of the reservoir.

1. Park the machine on level ground.
2. Set the machine to a safe condition.
For instructions, see *Safe Condition on page 9*.
3. Check the hydraulic fluid level sight glass.
4. Do one of the following:
 - If hydraulic fluid is visible in the sight glass, the fluid level is correct. Do not add hydraulic fluid.
 - If hydraulic fluid is not visible in the sight glass, add hydraulic fluid until it is visible in the sight glass.
For instructions, see *Add Hydraulic Fluid to the Reservoir*.

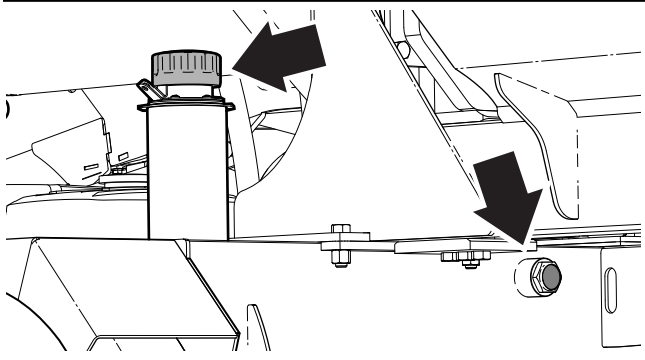

Fig. 19—Hydraulic fluid level sight glass and fill cap

6.5.3 Add Hydraulic Fluid to the Reservoir

IMPORTANT! Do not fill the hydraulic-fluid reservoir higher than the sight glass.

The hydraulic system uses **Dexron® III ATF**. Dexron VI or Mercon® are acceptable substitutes.

1. Check the hydraulic fluid level to make sure that the fluid level is low. For instructions, see *Check the Hydraulic Fluid Level*.
2. Turn the hydraulic-fluid fill cap counterclockwise to remove it.
3. Use a clean funnel to add hydraulic fluid to the reservoir until it is visible in the sight glass. **Do not overfill.**
4. Check the hydraulic fluid level.
5. Remove the funnel.
6. Install and secure the fill cap to prevent spillage.
7. Clean the area around the fill cap and wipe off any spilled fluid.

6.6 Start the Machine



WARNING!

Before you start the machine, read and understand all of the safety information in this manual and the engine manufacturer's manual.

IMPORTANT! Use short starting cycles (maximum five seconds) and wait one minute between cycles. If the engine does not start after repeated attempts, contact your local dealer or go to VanguardPower.com.

Before you start the machine, see the information under *Controls* on page 20.

1. Complete the tasks described in the *Pre-start Checklist* on page 26.
2. Make sure that the machine is level and in a stable position.
3. Move the hydraulic controls to the neutral position (out of detent).
4. Raise the throttle control 3/4 of the way to the **Fast** position.
5. Lift the choke control to the **Closed** position.
6. Insert the key, and then turn the ignition switch clockwise to the **Start** position. When the engine starts or after five seconds, release the key.
The ignition switch automatically rotates counterclockwise to the **Run** position.
7. Do one of the following:
 - If the engine started, continue with Step 8.
 - If the engine did not start, wait a minimum of one minute, and then repeat steps 6 and 7.
8. As the engine warms up, lower the choke control to the **Open** position.

6.7 Stop the Machine

IMPORTANT! Do not choke the carburetor to stop the engine.

1. Stop all machine operation (winching, cutting, and splitting).
2. Move the hydraulic controls to the neutral position (out of detent).
3. Move the throttle control to the **Stop** position to turn off the engine and close the fuel shut-off valve.
4. Activate each hydraulic control two or three times to relieve the hydraulic system pressure.

6.8 Emergency Stop

In the event of an emergency:

1. Move the hydraulic controls to the neutral position (out of detent).
2. Move the throttle control to the **Stop** position to turn off the engine and close the fuel shut-off valve.
3. Remove the cause of the emergency before starting the engine and resuming work.

6.9 Process Logs into Firewood

IMPORTANT! During operation, periodically check the bracing jacks to make sure the feet are firmly in the ground. The bracing jacks must support the log-loader chute weight to prevent machine damage.

The following procedure describes how to efficiently process logs into firewood:

1. Set up the machine.
For instructions, see *Machine Setup* on page 33.
2. Use the winch to move a log into position at the log-length guide.
For instructions, see the following:
 - *Winch Operation* on page 40.
 - *Position the First Log* on page 43.
 - *Position the Next Log* on page 48.
 - *Position the Last Log* on page 48.
3. Use the chain saw to cut the log. Let the cut section roll into the splitting cradle.
For instructions, see *Cut a Log* on page 46.
4. Split the cut log.
For instructions, see *Split Logs* on page 47.
5. While the push block automatically returns to the start position, repeat Step 2
6. After the push block is in the start position, repeat steps 3 through 5.
Continue this process until you produce the desired amount of firewood.

6.10 Machine Setup



Always use the machine outdoors and park the machine in a position where the prevailing winds blow the engine exhaust away from the operator. Exhaust from the engine contains carbon monoxide (CO) that can accumulate to a dangerous level, even in an area with good air flow.

W006

Use the tow vehicle to position the firewood processor at the work area. For more information, see *Create a Safe Work Area on page 11*.

- **Select a safe work area and machine location:**
 - **Ground should be firm and level.**
 - **Area must be clear of stones, branches, or hidden obstacles that might cause a tripping, hooking, or snagging hazard.**
 - **There must be no overhead hazards such as branches, cables, and electrical wires.**
- **Identify a safe split stack location. If applicable, stack split wood on level ground. Make sure the split stack does not interfere with safe operation of the machine.**

Set up the machine:

For more information, see *Fig. 30 on page 34*.

1. Chock the machine wheels to prevent movement.
2. Disconnect the machine from the tow vehicle.
For instructions, see *Disconnect from a Ball-Mount Hitch on page 53*.
3. Adjust the trailer jack to level the machine.
For instructions, see *Lower the Trailer Jack on page 53*.
4. Unfold the lead-in and log-loader chutes.
For instructions, see *Unfold the Lead-in and Log-Loader Chutes on page 35*.
5. Unfold the splitter chute.
For instructions, see *Unfold the Splitter Chute on page 36*.
6. Set the splitter chute to the required height.
For instructions, see *Set the Splitter Chute Height on page 36*.
7. Adjust the bracing jacks until the feet are set firmly in the ground and they support the log-loader chute.
Make sure the bottom edge of the lead-in chute is level with and touches the ground to avoid logs getting snagged.

8. Check the log stabilizer and chain to make sure the log stabilizer moves freely.
The log stabilizer keeps the log from rolling freely.
9. Do one of the following:
For pivot tongue instructions, see *Turn the Pivot Tongue on page 52*.
 - Move a wagon, trailer, or conveyor into position under the splitter chute to collect the split wood. If required, pivot the trailer tongue.
 - Pivot the trailer tongue to prevent it from interfering with or being buried in the stack of split wood.

Numbers correspond with the steps for *Machine Setup* on page 33.

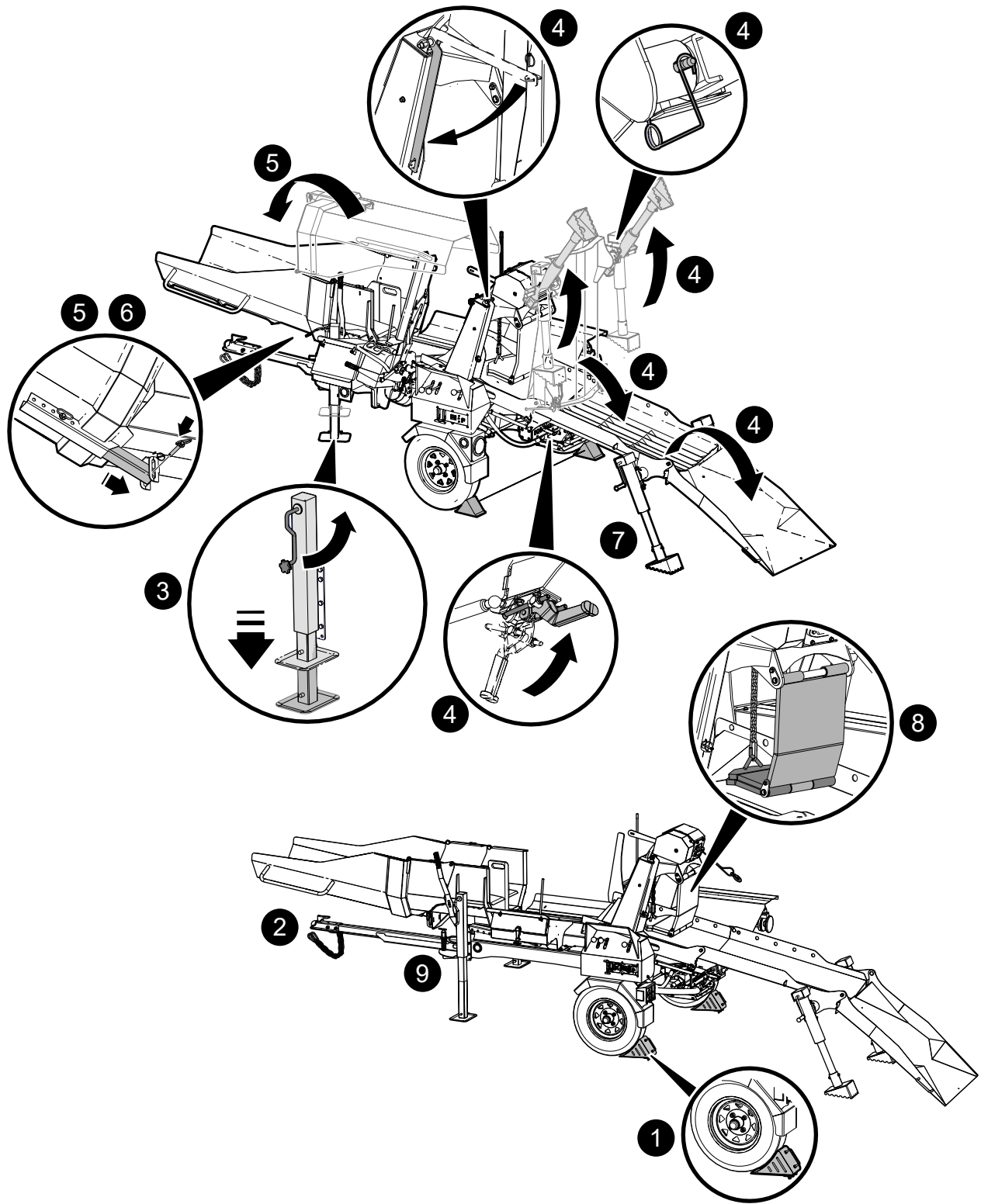

Fig. 30– Machine setup

6.10.1 Unfold the Lead-in and Log-Loader Chutes

1. Lift the bracing jacks to the brace position.
For each jack:
 - Remove the snapper pin.
 - Lift the jack up to the brace position.
 - Install the snapper pin to secure the jack.
2. Hold the log-loader chute to prevent it from falling, while you disconnect the log-loader chute lock arm:
 - Remove the linchpin from the tab on the LH side of the log-loader chute.
 - Remove the lock arm from the log-loader chute and rotate it down to the machine frame. Make sure the tab on the LH side of the machine frame goes through the lock arm slot.
 - Insert the linchpin through the tab to secure the lock arm.
3. Carefully fold down the log-loader and lead-in chutes until the bracing jacks are on the ground.
4. Close the two toggle-clamp latches to secure the log-loader chute. The latches are located below the log-loader chute (one on each side):
 - Rotate the handle down to the open position.
 - Place the latch bar over the catch plate.
 - Rotate the handle up to the closed position.
5. Use the handle to unfold the lead-in chute.
6. Adjust the bracing jacks until the feet are set firmly in the ground and they support the log-loader chute. Make sure the bottom edge of the lead-in chute is level with and touches the ground to avoid logs getting snagged.

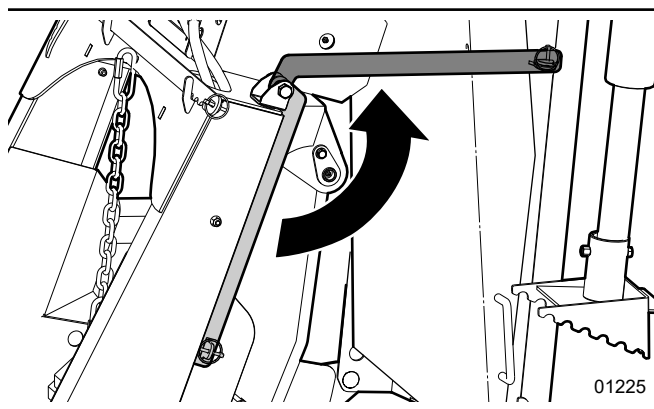

Fig. 20—Lock arm and latch pin

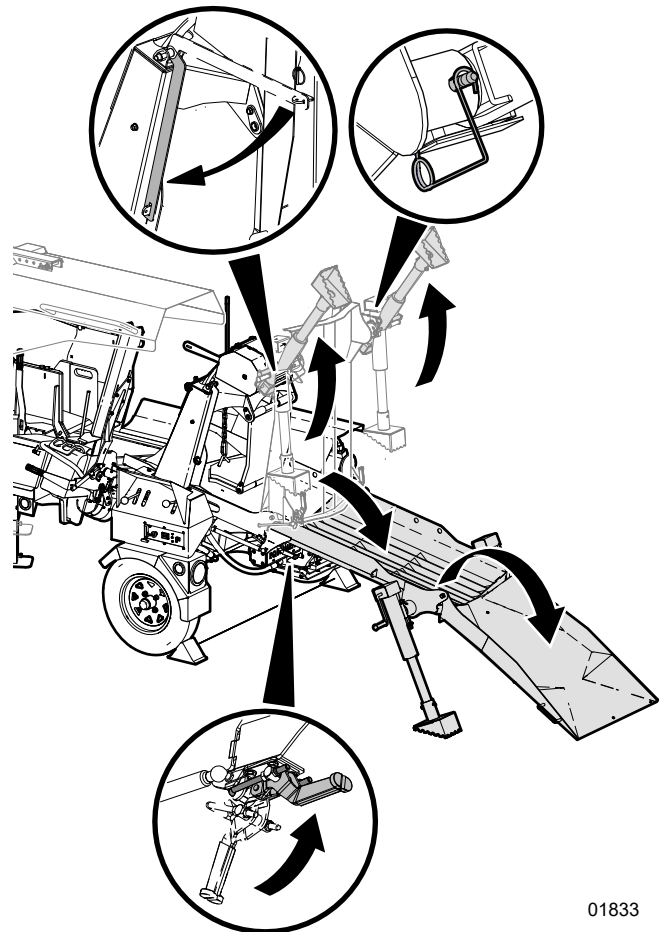

Fig. 21—Unfold the lead-in and log loader chutes

6.10.2 Unfold the Splitter Chute

1. Remove the linchpin from the tab on the LH side of the exit chute.
2. Remove the hitch pin from the splitting-cradle bracket. Remove the linchpin, and then slide it out.
3. Carefully unfold the splitter chute. Make sure the square tube on the bottom of the splitter chute goes between the bracket on the end of the splitting cradle.
4. Insert the hitch pin through the splitting-cradle bracket and splitter chute. Insert the linchpin through the hitch pin.
5. Insert the linchpin from Step 1 through the tab you removed it from for safekeeping.

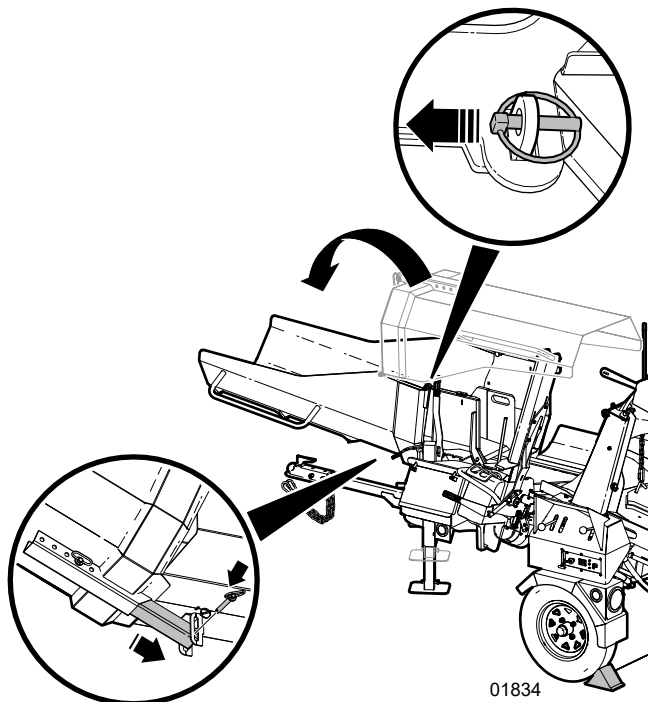

Fig. 22 – Unfold the splitter chute

6.10.3 Set the Splitter Chute Height

The maximum height the front end of the splitter chute can be set to is 54" (1.37 m).

1. Slightly lift the splitter chute to take the load off the adjustment bracket.
2. Remove the linchpin from the hitch pin.
3. Pull the hitch pin out of the splitter chute.
4. Raise or lower the splitter chute to the required height. Line up the hitch pin holes.
5. Insert the hitch pin through the holes.
6. Insert the linchpin through the hitch pin to secure it.

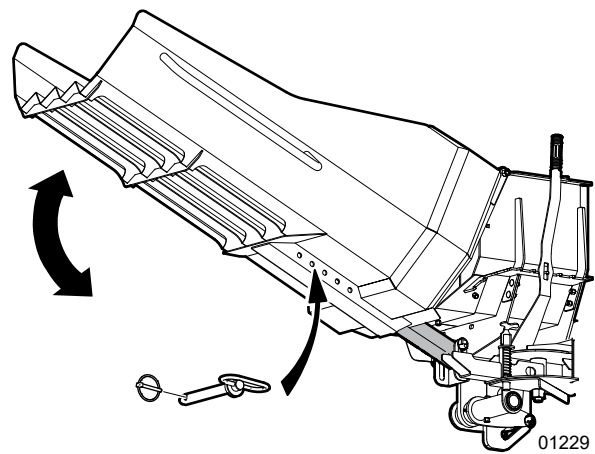

Fig. 23 – Set the splitter chute height

6.10.4 Set the Splitting-Wedge Height

Adjust the height of the splitting wedge for one of the following split types:

- Even-sized, four-way splits up to 22" (56 cm): align the center of the splitting wedge with the center of the log.
- Smaller logs: lower the splitting wedge to the lowest setting for a two-way split.

For more information, see *Splitting-Wedge Height Adjustment Lever* on page 23.

Procedure:

1. Slightly pull the lever out of the adjustment cog.
2. Move the handle along the adjustment bar to the raise or lower the splitting-wedge height.
3. Release the lever into an adjustment cog to set the splitting-wedge height.

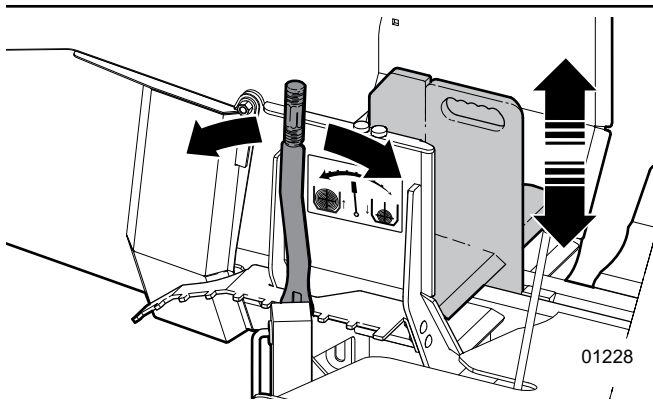

Fig. 24 – Set the splitting-wedge height

6.10.5 Set the Log-length Guide

Set the log-length guide to the desired log length for consistent saw cuts. The log-length guide can be set to cut logs from 14–24 inches (37–61 cm). Each setting is 2 inches (5 cm) apart. The log cut lengths are shown on top of the guide rail.

1. Remove the snap-lock pin.
2. Move the guide to the desired position along the slide.
3. Insert the snap-lock pin to secure the guide.

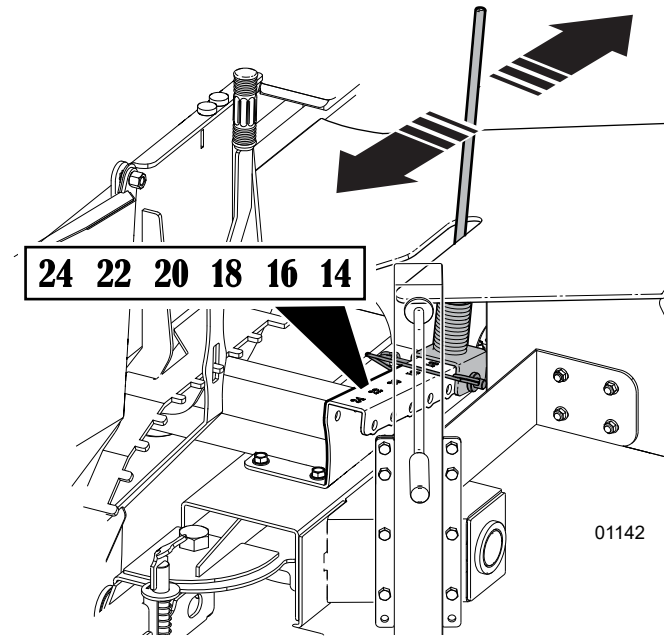

Fig. 25 – Set the log-length guide

6.11 Attach a Chain Saw to the Holder

CAUTION!

Before starting this procedure, review the chain saw manufacturer's manual for safe operating and handling procedures.

WARNING!

Do not attach a chain saw with a bar length longer than 30 inches (75 cm) to the holder. The cutting chain could contact the push block or cylinder rod and cause a hazardous situation. Injury or machine damage could result from flying debris.

IMPORTANT! The chain saw must have dual bar-mounting studs to mount to the universal chain saw adapter. Chain saws with captive guide bar nuts require them to be replaced with bushing spacers.

A chain saw with a bar length between 22–24 inch (56–61 cm) is recommended for this machine.

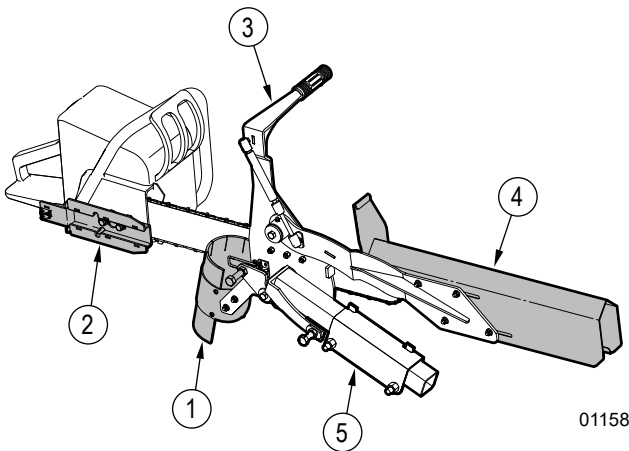
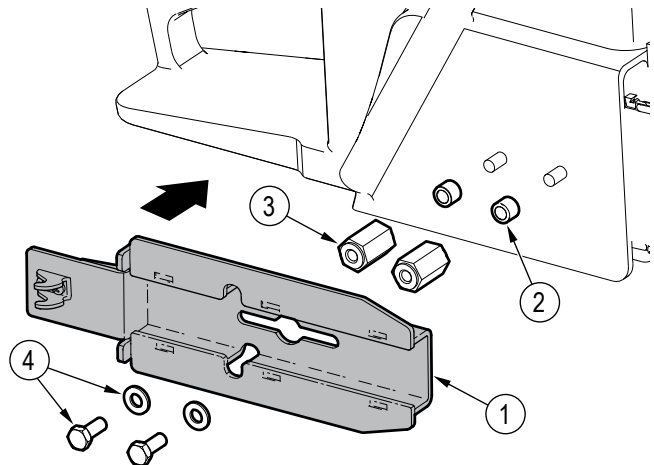

Fig. 26—Pivoting chain-saw holder

- | | |
|--------------------------------|----------------|
| 1. Debris chute | 4. Chain guard |
| 2. Universal chain saw adapter | 5. Pivot base |
| 3. Pivot handle | |

Procedure



01137

Fig. 27—Install a universal chain saw adapter

- | | |
|--------------------------------|--------------------------|
| 1. Universal chain saw adapter | 3. Bar-mounting studs |
| 2. Bushing spacers | 4. Hex bolts and washers |

1. Remove the chain-sprocket cover nuts from your chain saw. Some chain saws feature captive guide bar nuts in the chain-sprocket cover. For this type of saw, replace the guide bar nuts with bushing spacers (2).
2. Thread the two bar-mounting studs (3) onto the chain saw guide bar studs.
3. Install the adapter (1) over the bar-mounting studs.
4. Fasten everything together with the two M8 x 20 mm hex bolts and washers (4).
5. Open the holder draw latch. For more information, see *Fig. 29 on page 39*.
6. Slide the adapter into the guides on the holder.

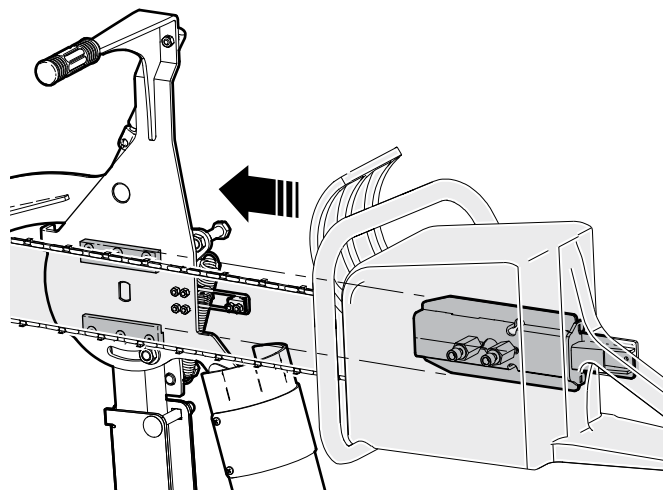

Fig. 28—Slide the adapter into the holder

7. Close the draw latch over the catch on the adapter. This secures the chain saw to the holder.

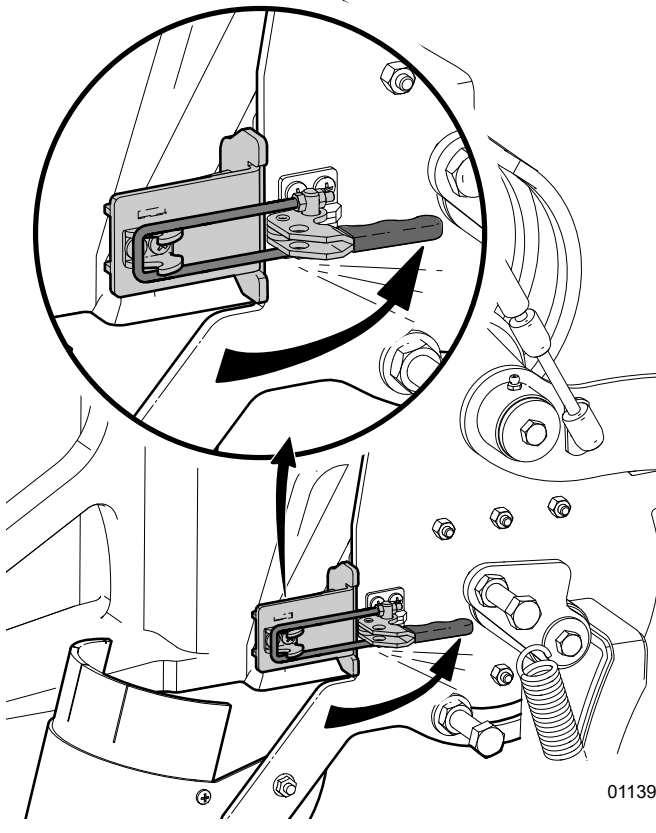

Fig. 29—Holder draw latch

8. Rotate the holder and move the chain saw through the full range of motion. Make adjustments to the pivot base, as required (based on the saw length).
9. Check the chain saw range of motion. Make sure the chain-saw bar cannot contact any part of the machine. If required, remove the chain saw from the holder and adjust the adapter position.

6.12 Winch Operation

Winch logs into the machine for processing

6.12.1 Winch Safety

WARNING!

Risk of machine roll over. Rope pull angle must not exceed 25° from the center axis of the machine. Exceeding that angle can subject the machine to a tipping load and cause the machine to roll over.

W074

WARNING!

Synthetic rope that fails under tension can snap back with great force causing injury or death. Avoid sudden jerks, quick starts or stops. Start slowly and smoothly. Replace if kinked, badly frayed, has knots, cuts, or broken strands.

W095

CAUTION!

Always make sure the area is clear of bystanders when operating the winch. Never use the winch to hold or secure loads.

W055

CAUTION!

Stay clear of the winch rope while winching. Injury from entanglement or rope burn could occur!

W056

IMPORTANT! The winch is designed to use synthetic rope. Only use synthetic rope as a replacement. Using anything else creates an unsafe work environment and voids the warranty.

- Never stand in line with the path of a rope that is under tension. If the rope breaks under tension, it can snap back in an unpredictable direction with great force. The recoil may cause injury or death to a person in its path.
- Always keep hands clear of the winch rope, hook loop, hook, and fairlead opening during installation, operation, and when spooling in or out. Never touch the winch rope or hook while it is under tension or under load.
- Always use the winch strap or a choker chain to attach to a log. The winch rope can be damaged if it is dragged under the log (when a winch strap or choker chain is not used).
- Always make sure that the anchor you select can withstand the load and the strap or chain cannot slip.
- Never engage or disengage the winch gear if the winch is under load, winch rope is under tension, or the drum is moving.
- For stability, make sure that the jacks are secure and the machine is supported in a level position before winching.
- Do not winch across or down a slope; always winch up a slope. Winching across or down a slope could cause the log to roll resulting in crushing injuries.
- Before using the winch, check the rope condition. If the rope is knotted, has broken strands, or sharp kinks, it may break during operation. Replace the rope if it is damaged. Do not touch the rope during operation.
- Do not allow anyone within 10 ft (3 m) of logs during winching. Logs can roll in unpredictable ways.
- Wind in the rope under load. The rope does not wind in correctly without a load.
- Always be aware of hazards when winching and moving logs. Inspect the work zone for the following hazards:
 - Objects along the winch route.
 - Structures close to or in the work zone.
 - Slopes or hills along the winch route.

- Never exceed a winching angle of $\pm 25^\circ$ from the centerline of the machine. If you are unsure of the winch angle, reposition the machine or use a snatch block (self-releasing pulley). Whenever possible, winch in line with the machine.

- When using a snatch block (self-releasing pulley), be aware of the danger zone that is created between the log, snatch block, and machine.

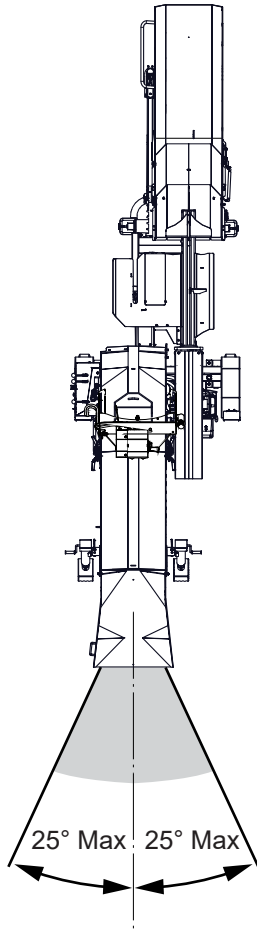
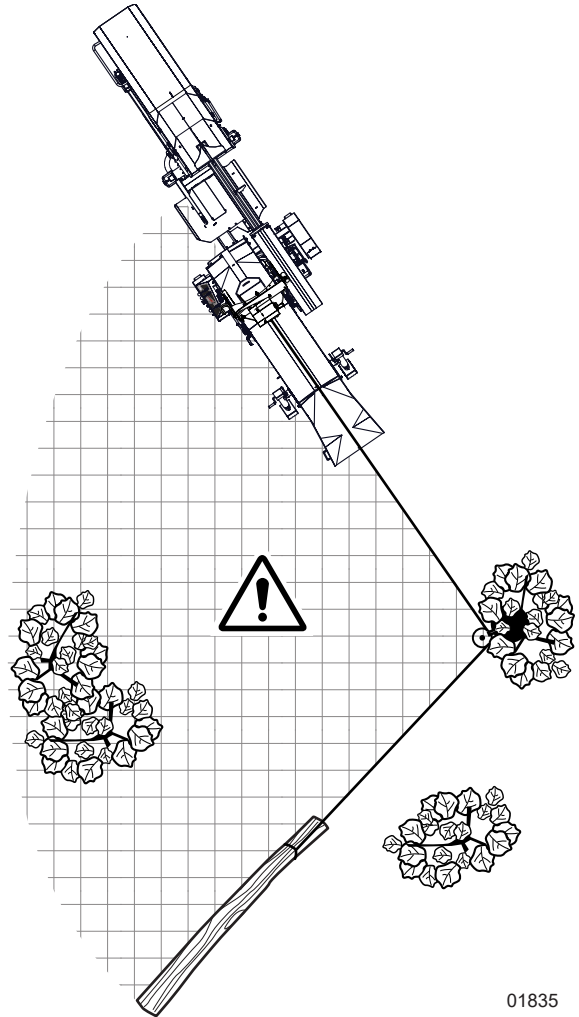

Fig. 31 – Safe winch angle



01835

Fig. 32 – Using a snatch block

6.12.2 Winch a Log

! WARNING!

Before using the winch, read and understand the information under *Winch Safety on page 40.*

1. Push the **winch gear lever** to the RH side (away from the operator) to disengage the winch gear.
For more information, see *Winch Gear Lever on page 22.*
2. Grasp the hook on the winch rope and pull the rope out to the logs.
3. Attach the 60" (1.5 m) winch strap to the log, and then attach the winch-rope hook to the strap. Do not attach the winch rope directly to the log. A standard log chain can be used in place of the winch strap.

4. Pull the **winch gear lever** to the LH side (toward the operator) to engage the winch gear.
5. Push and hold the **winch control lever** down to pull the log onto the lead-in chute. Make sure the log does not catch on the bottom edge of the lead-in chute.
For more information, see *Hydraulic Winch Control on page 22.*

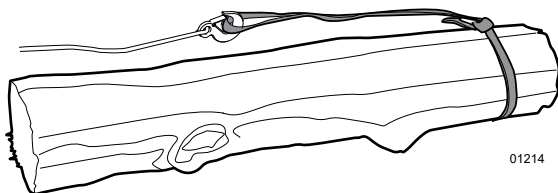

Fig. 33—Winch strap

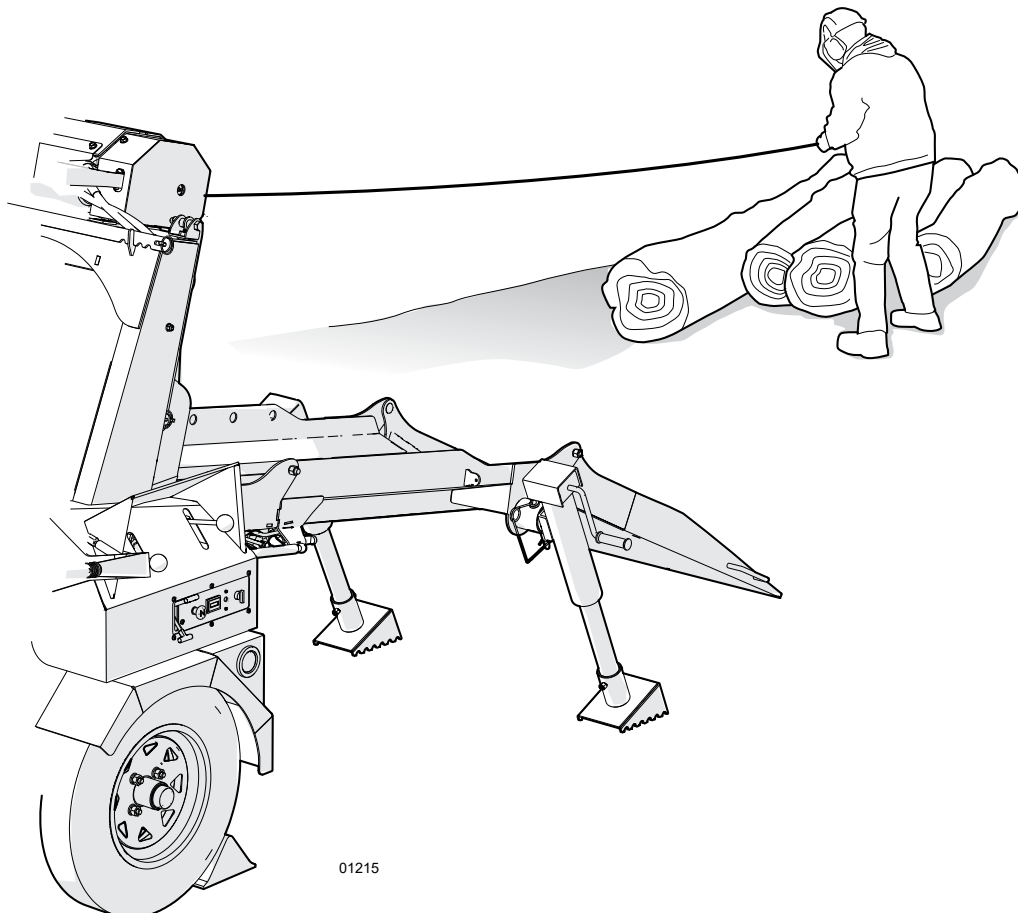

Fig. 45—Pull the winch rope out to the log

6.13 Position the First Log

WARNING!

The log stabilizer is heavy! Never attempt to push a log through the stabilizer opening by hand. The stabilizer could drop suddenly and cause serious injury. Always use the appropriate procedure and tools to push or pull a log through the opening.

IMPORTANT! Stop winching when the hook reaches the winch. If the operator is winching and the log is not moving, it is possible that the rope is fully retracted. If the operator continues winching, the end of the rope may pull off the hook.

1. Winch the first log to the machine. Make sure the log does not catch on the front edge of the lead-in chute. See *Fig. 34*.
2. Winch the log up the lead-in chute to the log stabilizer.
3. Stop the winch and make sure the log is stable.
4. Push the **winch gear lever** to the RH side (away from the operator) to disengage the winch gear.
5. Slightly, pull the rope out of the winch by hand.
6. Detach the hook from the winch strap.
7. Move the winch strap to the far end of the log. See *Fig. 35*.
8. Pull out the winch rope and reattach the hook to the winch strap.
9. Pull the **winch gear lever** to the LH side (toward the operator) to engage the winch gear.
10. Winch the log through the log stabilizer to the log-length guide.

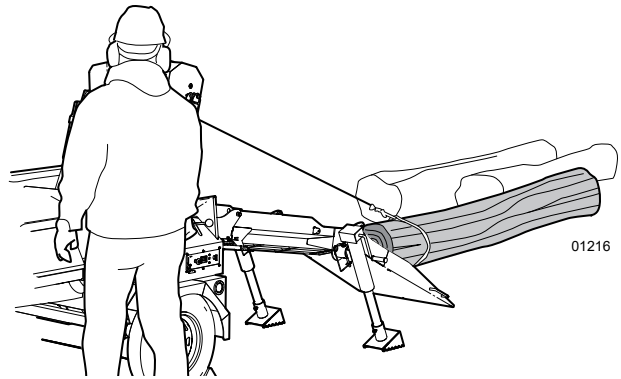

Fig. 34—Winch the first log to the machine

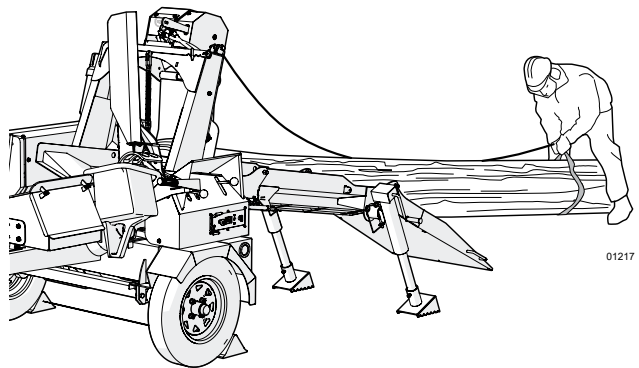

Fig. 35—Move the winch strap

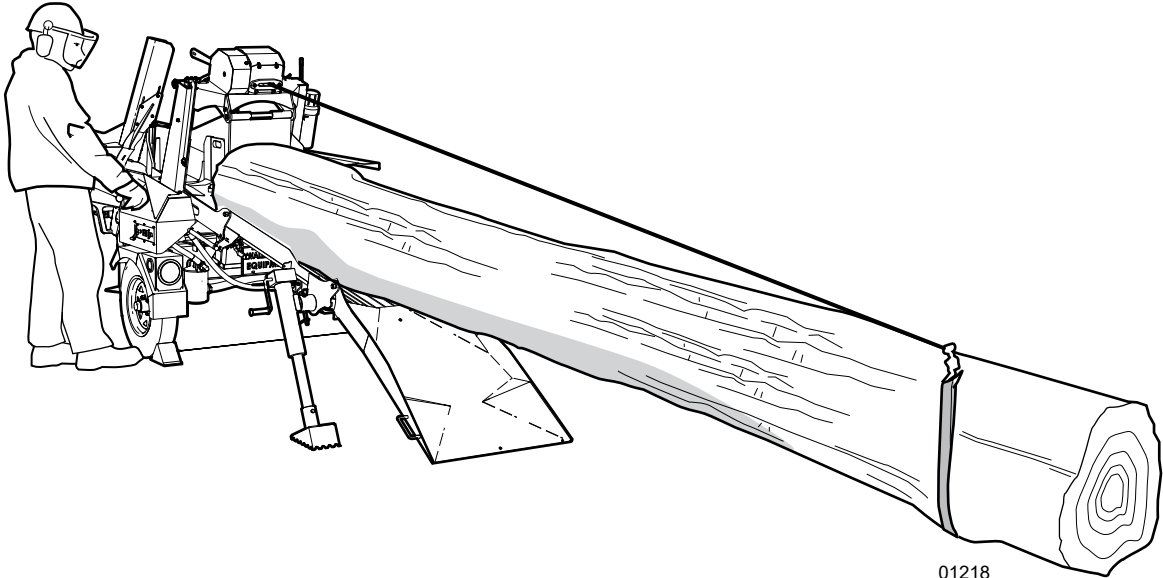

Fig. 46 – Position the log in the machine

6.14 Cut Logs

Position a log in the machine with the end touching the log-length guide. Use the chain saw to cut the log to the set length.

6.14.1 Chain Saw Safety

WARNING!

Read and understand the chain saw manufacturer's manual and follow all safety instructions.

Wear the appropriate PPE when using a chain saw.

CAUTION!

Always apply the brake before you leave a chain saw in idle.

Chain saws are inherently dangerous. Review the safety guidelines in the chain saw manufacturer's manual. The following list provides some general guidelines when using a chain saw:

- Only use a chain saw that you have been trained to use correctly and safely.
 - Make sure you understand the instructions before attempting to use any chain saw.
 - Operate, adjust, and maintain chain saw according to the manufacturer directions
 - Wear the PPE and clothing recommended by the chain saw manufacturer.
 - If you have any doubts about doing the work safely, ask questions.
 - Only operate a chain saw when you are well rested. Fatigue can cause carelessness.
 - Never use a saw chain that:
 - Has broken twice.
 - Is severely damaged.
 - Has excessive saw chain stretch.
 - Has broken or cracked components.
 - Have all the required supplies and equipment with you before you start the work.
 - Be aware of your surroundings, weather conditions, terrain, buildings, power lines, vehicles, and other people.
 - The correct chain tension provides good cutting action and increases the chain life. If the chain is too loose, it can derail; if it is too tight the chain can bind.
- Chain lubrication prolongs the life of the saw and increases safety.
 - Sharpen the saw chain if you see any of the following conditions:
 - The saw chain tends to track sideways while cutting.
 - The cut shows fine powder instead of chips.
 - There is a burnt wood smell.
 - It has loose rivet joints. If you can rotate the rivets with your fingers, they are too loose.
 - Make sure the chain saw is sharp and in good working order.

6.14.2 Start the Chain Saw

1. Open the holder draw latch.
2. Slide the chain saw out of the holder.
3. Start the chain saw.
For instructions, see the chain saw manufacturer's manual.
4. Carefully, slide the adapter into the holder guides.

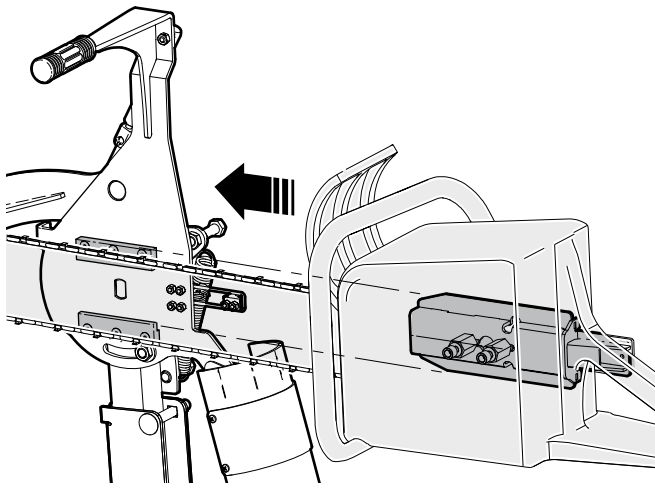

Fig. 36—Slide the adapter into the holder

5. Close the draw latch over the adapter catch to secure the chain saw to the holder.

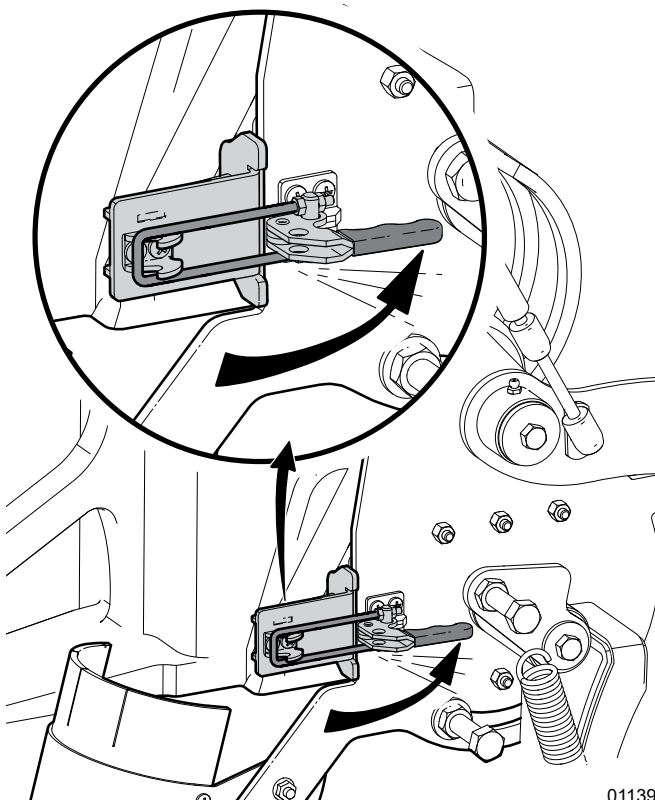

Fig. 37—Holder draw latch

6.14.3 Cut a Log

1. Make sure the log-length guide is set to the desired cut length and the end of the log is touching it. For instructions, see *Set the Log-length Guide on page 37*.
2. If required, start the chain saw. For instructions, see *Start the Chain Saw*.
3. Operate the saw as you normally would to cut a log. You can also use the holder pivot handle. The guard rests on top of the log, while the chain saw cuts through it.
4. Decrease the cutting pressure as you finish the cut. The cut log falls into the splitter.
5. Rotate the chain saw back to the idle position.

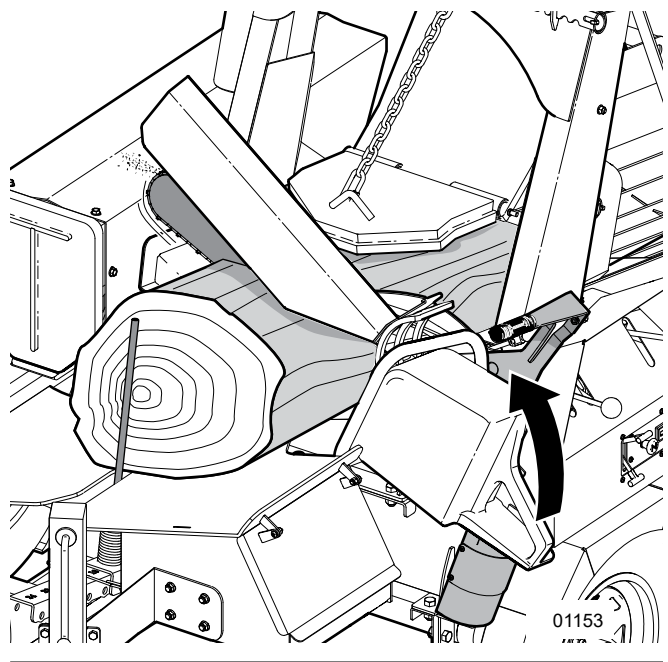

Fig. 38—Cut a log

6.15 Split Logs

CAUTION!



Risk of pinching or crushing hazard! Never reach into the splitting cradle to reposition a log. Use a log peavey, hookaroon or another tool.

W043



A six-way splitting wedge is available as an accessory.

After a log is cut, the cut section rolls into the splitting cradle.

For more information, see *Controls* on page 20.

1. Set the splitting-wedge height.
For instructions, see *Set the Splitting-Wedge Height* on page 37.

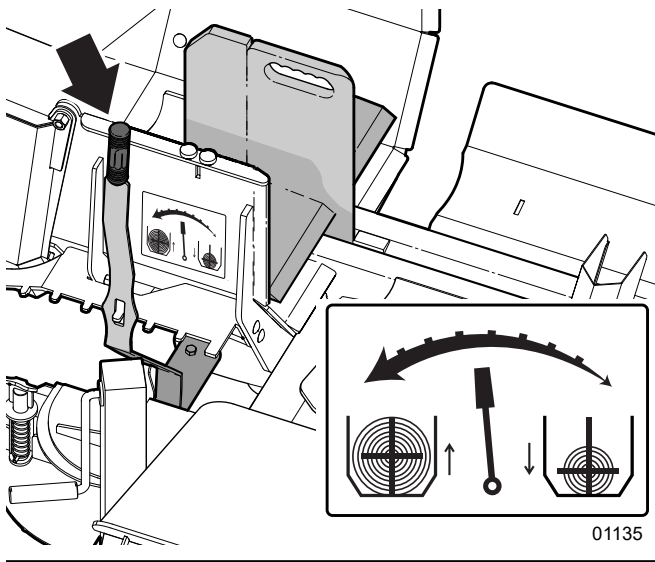

01135

Fig. 39—Set the splitting-wedge height

2. Simultaneously, push the **splitter cylinder extend** and **splitter cylinder retract** control levers down (into detent) to start **Auto Cycle**.
The push block extends to split the wood, and then retracts automatically. The control levers move to the neutral position automatically.

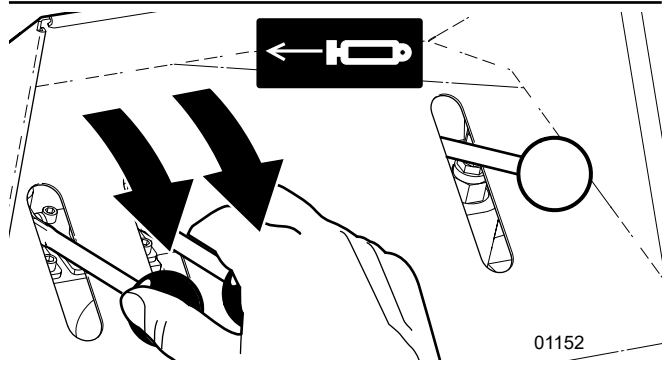

01152

Fig. 40—Push the two splitter cylinder control levers down

At the end of the push block's extend stroke, the **splitter cylinder extend** control lever moves to the neutral position (out of detent) automatically, and the push block retracts.

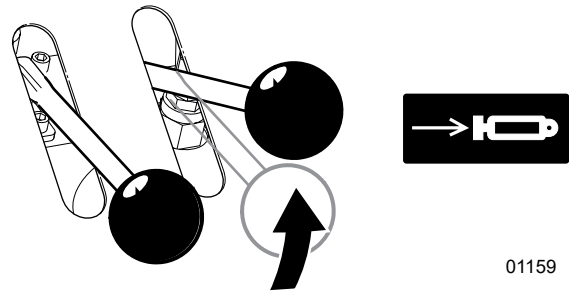

01159

Fig. 41—The push block retracts automatically

At the end of the push block's retract stroke, the **splitter cylinder extend** control lever moves to the neutral position (out of detent) automatically, and the push block is ready for the next cycle.

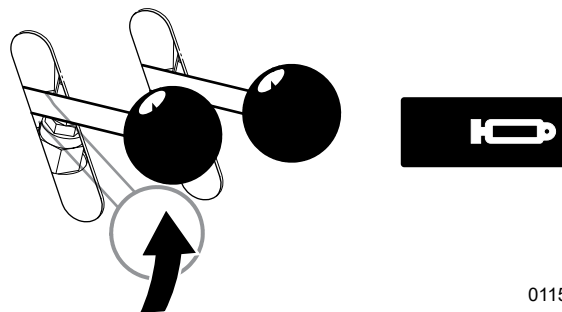

01154

Fig. 42—The push block is ready for the next cycle

6.16 Split Wood Discharge

Split wood is pushed off the end of the splitter chute as each additional log is split. Set the splitter chute height to pile firewood on the ground, on a conveyor, or in a trailer or wagon. For more information, see *Set the Splitting-Wedge Height on page 37*.

6.17 Position the Next Log

The log in the machine is repeatedly cut and becomes too short to winch forward. At this point, winch another log in behind the current log and use it to push the current log into the cutting area.

1. Make sure the log in the machine is stable.
2. Push the **winch gear lever** to the RH side (away from the operator) to disengage the winch gear.
3. Slightly pull the rope out of the winch by hand.
4. Detach the hook from the winch strap.
5. Pull the rope out to the next log.
6. Wrap the winch strap around the log. You may need to roll the log onto the strap using a log peavey.
7. Attach the hook to the winch strap.

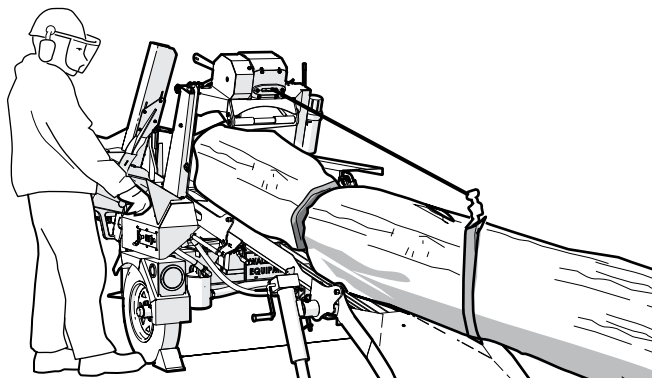

Fig. 43—Use the next log to push the previous one

8. Pull the **winch gear lever** to the LH side (toward the operator) to engage the winch gear.
9. Push and hold the **winch control lever** down to pull the log onto the entry chute. Position the log against the previous log. Use the next log to push the previous log forward to the log-length guide.
10. After a few log cuts, complete the following:
 - Repeat steps 1 through 4.
 - Move the winch strap to the far end of the log.
 - Repeat steps 6 through 8.
 - Push and hold the **winch control lever** down to pull the log forward to the log-length guide.

6.18 Position the Last Log

CAUTION!

Risk of serious injury. Never attempt to push a log through the stabilizer opening by hand. The stabilizer could drop suddenly and cause serious injury. Always use the appropriate procedure and tools to push or pull a log through the opening.

When you process the last log, you will find it is too short to winch into the machine. Use a hookaroon or peavey to push the last log forward to the log-length guide.

Be aware of the heavy log stabilizer and use extreme caution when processing the last log.

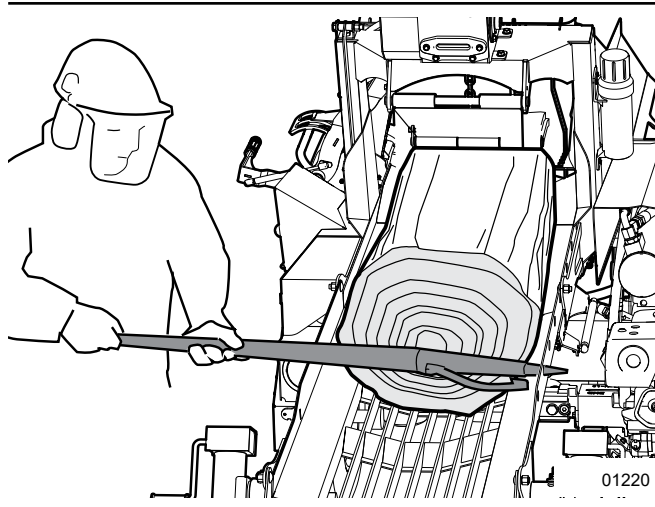

Fig. 44—Use an appropriate tool to push the last log forward

7. Transport

IMPORTANT! Equipment that is transported on a public roadway must comply with the local laws that govern the safety and transport of machinery.

Before taking the machine on a public roadway, make sure it has the required lighting, reflectors, and markings, and that they are in good, working condition.

For specific requirements, contact your local transportation authority.

7.1 Transport Safety

- Make sure that the machine is securely attached to the tow vehicle with a retainer through the hitch.
- Always attach the safety chains between the machine and the tow vehicle.
- Never allow riders on the machine.
- Do not exceed a safe travel speed. Slow down for rough terrain and cornering.
- Plan your route to avoid heavy traffic.
- Do not transport or move the machine with the engine running.
- Inspect the wheel rims for dents or damage and tighten the wheel lug nuts to the specified torque.
For more information, see *Wheel Lug Nut Torque on page 66*.
- Inspect the tires for cuts or damage.
- Make sure the tires are filled to the specified pressure. For correct tire pressure, see the tire sidewall.
- Make sure the tow vehicle is fitted with the correct size ball-mount hitch (2 inches).
- Secure all the machine guards, shields, and covers.
- Make sure that the fuel tank, oil tank, and hydraulic reservoir caps are installed and secure (to prevent spills during transport).
- Remove all debris from the machine.
- After the machine is prepared for transport, complete a circle check to make sure everything is safe, secure, and functions correctly.

7.2 Prepare the Machine for Transport

1. Turn off the chain saw and remove it from the holder.
2. If required, remove the winch rope and strap from the log.
3. Wind the winch rope into the winch.
4. Pull the **splitter cylinder extend** control lever up to retract the push block.
5. Move the hydraulic controls to neutral.
6. Stop the machine.
For instructions, see *Stop the Machine on page 32*.
7. Actuate each hydraulic control to relieve the pressure.
8. Remove all material from the lead-in chute, log-loader chute, splitting cradle, and splitter chute.
9. Fold up the splitter chute.
For instructions, see *Fold Up the Splitter Chute on page 51*.
10. Fold up the lead-in and log-loader chutes.
For instructions, see *Fold Up the Lead-In and Log-Loader Chutes on page 51*.
11. Remove all loose tools and debris from the machine.
12. Attach the machine to a tow vehicle.
For instructions, see *Attach to a Tow Vehicle on page 52*.

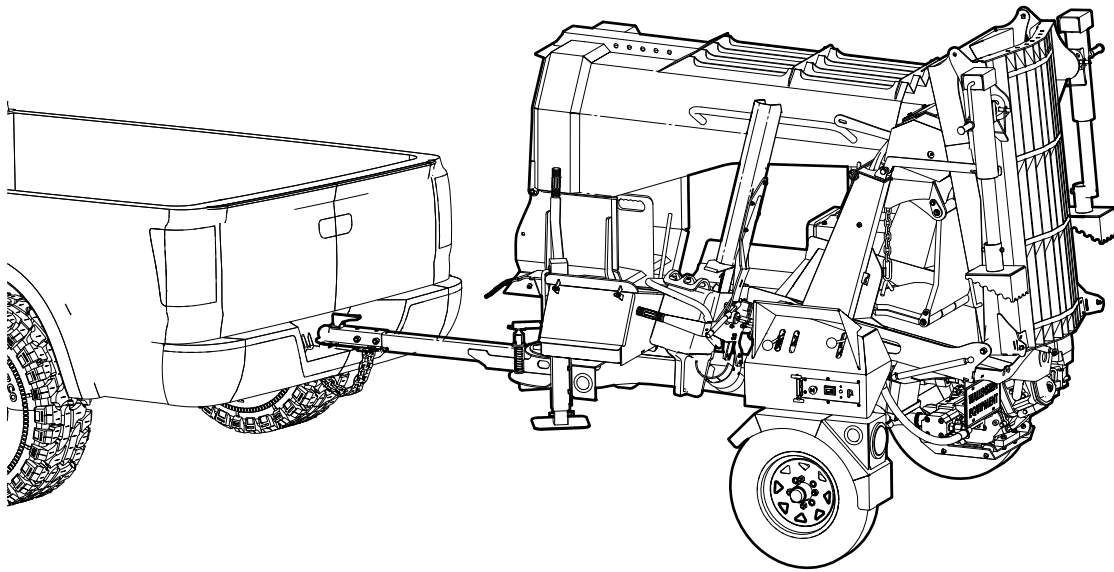

Fig. 47 – Transport position (WP845)

7.2.1 Fold Up the Lead-In and Log-Loader Chutes

1. Remove the linchpin from the tab that secures the latch bar in position. Keep it accessible to secure the chutes.
2. Use the handle to lift up the lead-in chute and rotate it until it is resting on top of the log-loader chute.
3. Open the two toggle-clamp latches to release the log-loader chute. The latches are located below the log-loader chute (one on each side):
 - Rotate the handle down to the open position.
 - Remove the latch bar from the catch plate.
 - Rotate the handle up to the closed position.
4. Fold up the log-loader and lead-in chutes.
5. Lift the latch bar and slide it over the tab on the LH side of the log-loader chute.
6. Install the linchpin (removed in Step 1) through the log-loader tab to secure the chutes.
7. Rotate each of the two bracing jacks to the vertical position:
 - Remove the snap pin.
 - Rotate the bracing jack.
 - Insert the snap pin.

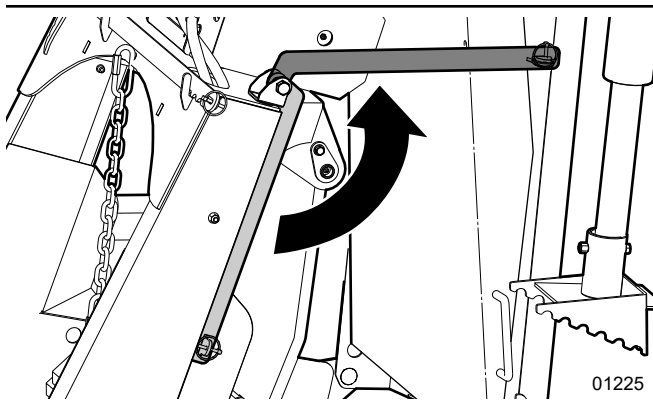

Fig. 48—Lock arm and latch pin

7.2.2 Fold Up the Splitter Chute

1. Remove the linchpin from the tab on the LH side of the splitting wedge guard.
2. Remove the hitch pin that secures the splitter chute to the splitting cradle. Remove the linchpin, and then slide it out.
3. Use the handle to carefully fold up the splitter chute.
4. Insert the linchpin (removed in Step 1) through the tab you removed it from to secure the splitter chute.
5. Insert the hitch pin through the splitting-cradle bracket (removed in Step 2) for safekeeping. Insert the linchpin through the hitch pin.

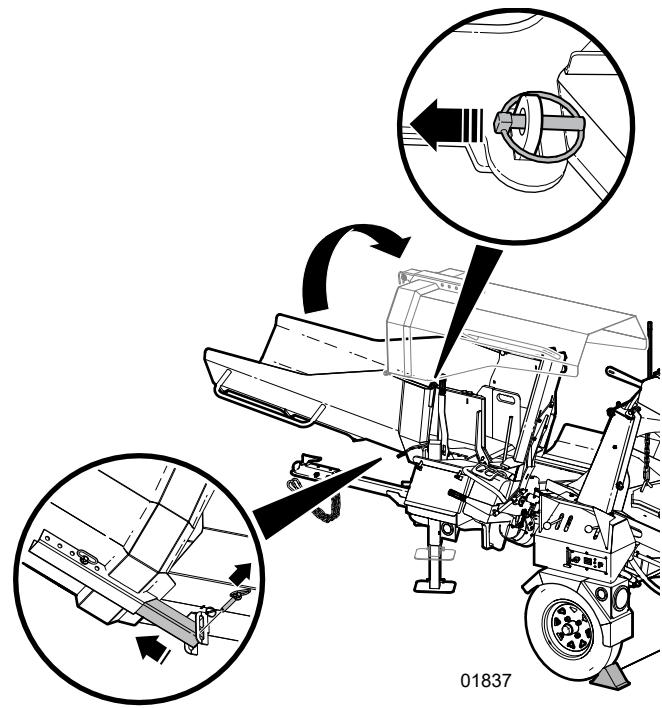

Fig. 49—Fold up the splitter chute

7.3 Attach to a Tow Vehicle

WARNING!

Before moving the tow vehicle, make sure the safety chains are securely attached.

W103

CAUTION!

Before moving the machine, make sure that the pivot-tongue lock pin is fully engaged.

IMPORTANT! Before attaching the machine to a tow vehicle, fold up the splitter chute and lead-in and log-loader chutes. Failure to fold up the chutes may result in damage to the machine.

Always park the machine on a level, dry area that is free of debris and other foreign objects before connecting or disconnecting a hitch.

7.3.1 Turn the Pivot Tongue

The machine has a trailer pivot tongue with a two-inch ball-mount hitch coupler.

Sometimes it is not possible to align the tow vehicle with the front of the machine (for example; the split wood stack is blocking the path). Turn the pivot tongue to reposition the machine and connect it to the tow vehicle.

1. Lift the pivot-tongue lock pin.
Make sure the pivot-tongue lock and the area around it are clear of debris.
2. Rotate the pivot tongue to the desired position.
3. Prepare the machine for transport.
For instructions, see *Prepare the Machine for Transport on page 49*.
4. Attach the machine to a tow vehicle.
For instructions, see *Connect to a Ball-Mount Hitch*.
5. Slowly begin to drive the tow vehicle forward.
As the tow vehicle moves forward, the machine turns to align with the tongue. When the pivot tongue aligns with the machine, the lock pin snaps into the locked position.

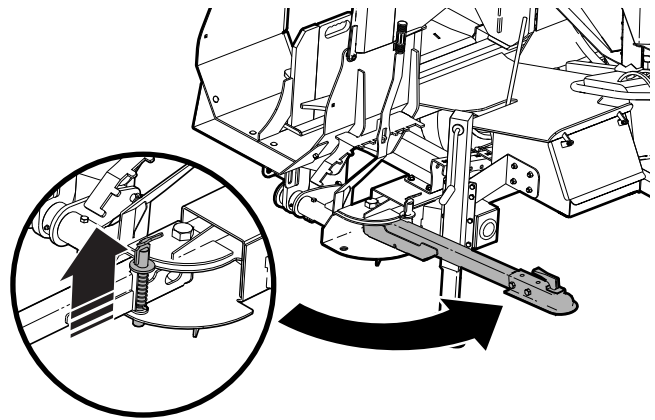

Fig. 50 – Pivot tongue

7.3.2 Connect to a Ball-Mount Hitch

Make sure there is enough room and clearance to safely reverse the tow vehicle to the machine.

1. Reverse the tow vehicle to the machine. Stop about 1 ft (30 cm) away from the hitch coupler. If a back-up camera is not available, have another person guide you.
2. Use the trailer jack to raise the trailer tongue until the hitch coupler is higher than the ball-mount hitch.
3. Remove the snap-lock pin from the hitch-coupler latch. Raise the latch to the upright (unlocked) position.
4. Slowly, reverse the tow vehicle until the ball-mount hitch is below the hitch coupler. Stop the tow vehicle and apply the parking brake.
5. Use the trailer jack to lower the machine and install the hitch coupler over the ball-mount hitch.
For instructions, see *Lower the Trailer Jack on page 53*.
6. Lower the hitch-coupler latch to the locked position. Install the snap-lock pin through the latch to secure the hitch coupler to the ball-mount hitch.
7. Raise and stow the trailer jack.
For instructions, see *Stow the Trailer Jack on page 53*.
8. Cross the two safety chains below the tongue, and then attach them to the tow vehicle (one on each side of the ball-mount hitch).
9. Connect the light-bar cable harness to the tow vehicle. Make sure the cables are long enough to make turns without tension, but do not drag on the ground.
10. Check the function of all the lights. Activate each light and have another person call out to confirm that it functions correctly.
11. Remove the chocks from the machine wheels.

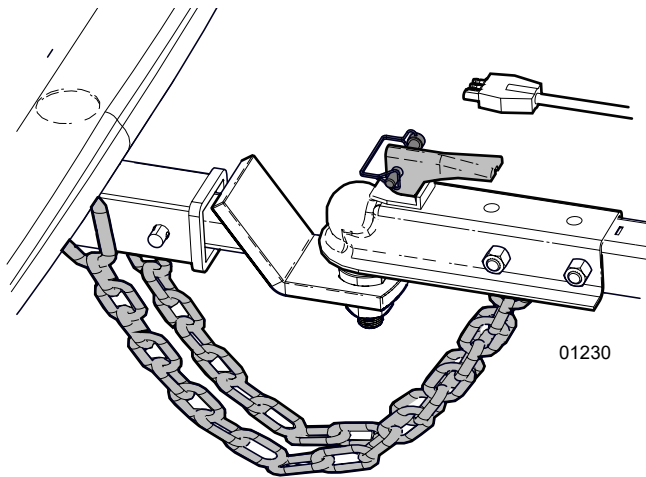

Fig. 51 – Ball-mount hitch connection

7.3.3 Disconnect from a Ball-Mount Hitch

Make sure there is enough room and clearance to safely drive the tow vehicle forward, away from the machine.

1. Stop the tow vehicle in a location where it and the machine are on level ground. Turn off the engine and apply the parking brake.
2. Chock the machine wheels to prevent movement.
3. Rotate and lower the trailer jack to support the machine. For instructions, see *Lower the Trailer Jack*.
4. Disconnect the light-bar cable harness from the tow vehicle. Stow the cable harness safely on the machine.
5. Remove the two safety chains from the tow vehicle and stow them securely on the machine.
6. Remove the snap-lock pin from the hitch-coupler latch. Raise the latch to the upright (unlocked) position.
7. Use the trailer jack to raise the trailer tongue until the hitch coupler is higher than the ball-mount hitch.
8. Slowly, drive the tow vehicle forward until the ball-mount hitch is clear of the hitch coupler. Stop the tow vehicle and apply the parking brake.
9. Use the trailer jack to lower the machine until it is level with the ground.
10. Lower the hitch-coupler latch to the locked position. Install the snapper pin through the latch.

7.3.4 Lower the Trailer Jack

1. Remove the pin.
2. Rotate the jack to the vertical position.
3. Insert the pin.
4. Turn the handle to lower the jack leg.

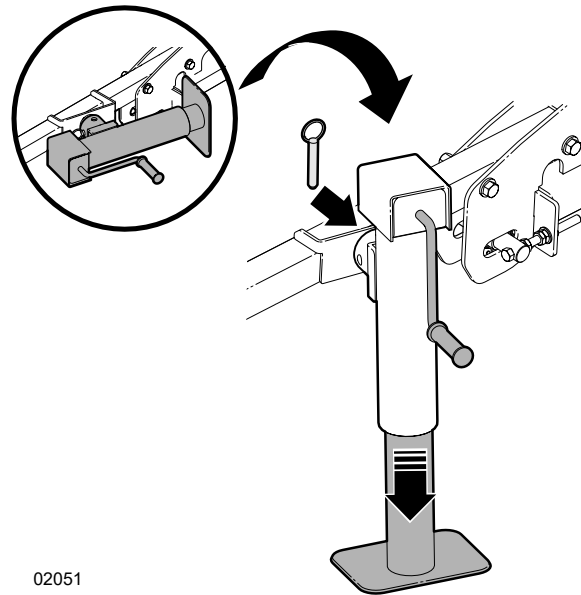

Fig. 52 – Lower the trailer jack

7.3.5 Stow the Trailer Jack

For reference, see *Fig. 52*.

1. Turn the handle to raise the jack leg.
2. Remove the pin.
3. Rotate the jack to the horizontal position.
4. Insert the pin.

8. Storage

At the end of the season or when the machine is not going to be used for an extended period of time, completely inspect all of the major systems. Replace or repair any worn or damaged components to prevent unnecessary down time at the beginning of the next season. Touch up scratches or dents.

For reference, see *Fig. 53 on page 55*.

8.1 Storage Safety

WARNING!

Do not permit children to play on or around stored machinery or equipment. Sharp edges, unexpected movement, trips, falls, and other hazards can cause serious injury or death.

W105

- Store the machine in a dry, level location away from human activity.
- Store the machine indoors, where possible.
- Support the frame with planks, if required.

8.2 Place the Machine in Storage

For information about engine storage, see the engine manufacturer's manual.

1. Turn off the chain saw and remove it from the holder.
2. If required, remove the winch rope and strap from the log.
3. Wind the winch rope into the winch.
4. Fully retract the push block.
5. Move the hydraulic controls to neutral.
6. Stop the machine.
For instructions, see *Stop the Machine on page 32*.
7. Actuate each hydraulic control to relieve the pressure.
8. Remove all material from the lead-in chute, log-loader chute, splitting cradle, and splitter chute.
9. Use a pressure washer or water hose to thoroughly wash the machine. Remove all dirt, mud, and debris.
10. Check all moving parts for entangled material. Remove all entangled material.
11. Check the condition of the winch rope. Replace or adjust the rope, as required.

12. Do one of the following:

- If the machine will be in storage for one to three months, add stabilizer to the engine fuel and drain the carburetor.
- If the machine will be in storage for longer than three months, replace the engine fuel with an alkylate or appropriate engineered fuel. These fuel types prevent the buildup of insoluble solids (deposits) in the engine. For more information, see *Engine Fuel on page 57*. For instructions, see *Replace the Engine Fuel*.

13. Park the machine in the storage location.

14. Disconnect the tow vehicle.

For instructions, see *Disconnect from a Ball-Mount Hitch on page 53*.

15. Adjust the trailer jack until the machine is level. If soft ground is unavoidable, place boards or plates under the jack to increase the surface area.

16. Chock the machine wheels to prevent accidental movement and increase the wheel bearing life.

17. If indoor storage is not possible, cover the machine with a waterproof tarp. It is recommended that the machine be stored indoors.

8.2.1 Replace the Engine Fuel

1. Remove the current fuel from the engine.
Operate the machine until the fuel tank is empty or drain the fuel tank and properly dispose of the fuel.
2. Add new fuel to the engine.
For instructions, see *Add Fuel to the Engine on page 29*.
3. Start the machine.
For instructions, see *Start the Machine on page 32*.
4. Wait five to 10 minutes for the fuel to flush the carburetor.
5. Stop the machine.
For instructions, see *Stop the Machine on page 32*.

8.3 Remove the Machine from Storage

1. Complete the *Pre-start Checklist on page 26*.
2. Complete the required maintenance.
For maintenance requirements, see the *Maintenance Schedule on page 58*.

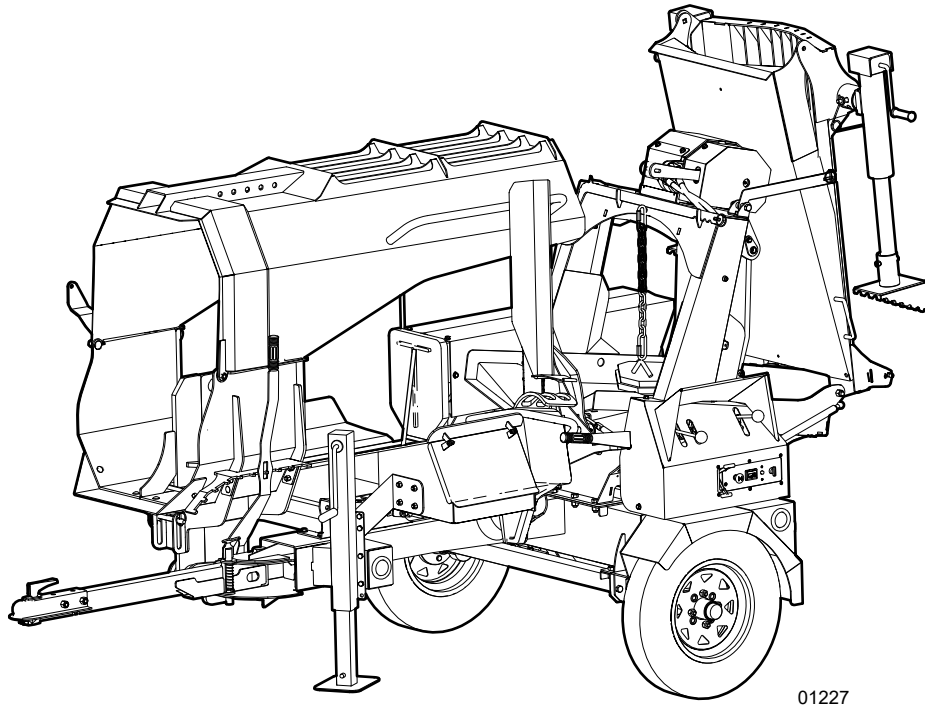

01227

Fig. 53 – Storage (WP875)

9. Service and Maintenance

Regular preventive maintenance can improve performance and prolong the life of the machine. Machine maintenance is your responsibility.

9.1 Service and Maintenance Safety

WARNING!

Risk of serious personal injury. Stop engine before performing ANY service or maintenance procedure. Reinstall all covers and shields removed before putting machine back into service.

W033

WARNING!

Before you start service or maintenance work:

- **Set the machine to a safe condition.**
- **Wait for the machine to cool down. Engine components and fluids may be hot enough to cause burns.**
- **Read and understand all of the service and maintenance safety information.**

W041

WARNING!

Wear the personal protective equipment (PPE) that is required to complete the work safely.

This includes, but is not limited to a hard hat, hearing protection, a face shield, protective footwear, a respirator, and heavy gloves.

W101

Place the machine in a safe condition before you start any service or maintenance:

SAFE CONDITION

1. Set the tow vehicle's parking brake, turn off the engine, and remove the ignition key.
 2. Chock the machine wheels to prevent movement.
 3. Remove the winch rope from the log and wind it into the winch.
 4. Set the hydraulic controls to neutral and wait for all motion to stop.
 5. Turn off the chain saw.
 6. Turn off the engine.
 7. Disconnect the engine spark-plug wire and keep it away from the spark plug.
 8. Actuate each hydraulic control to relieve the pressure.
 9. Remove all material from the lead-in chute, log-loader chute, splitting cradle, and splitter chute.
- Follow good shop practices:
 - Keep the work area clean and dry.
 - Ground electrical outlets and tools.
 - Have adequate light for good visibility.
 - Never operate an engine inside a closed building. The exhaust fumes may cause asphyxiation.
 - Wait for the machine to cool before starting work. Components and liquids may be hot enough to cause burns.
 - Never work under equipment unless it is securely supported with blocks.
 - When replacement parts are necessary, use genuine factory replacement parts to restore your equipment to original specifications. The manufacturer cannot be responsible for injuries or damages caused by use of unapproved parts or accessories.
 - Keep a fire extinguisher and first aid kit readily accessible at all times.
 - Do not use gasoline or diesel fuel to clean parts. Use a regular cleanser.
 - Replace all machine guards, shields, and covers before machine operation.

9.2 Fluids and Lubricants

The machine requires various fluids and lubricants for operation and maintenance.

9.2.1 Lubricant Handling and Storage

For optimum machine efficiency, use clean lubricants and clean containers to handle all lubricants. Store lubricants in an area that is protected from dust, moisture, and other contaminants.

9.2.2 Engine Oil

For engine maintenance and service information, see the engine manufacturer's manual.

Briggs & Stratton® Warranty Certified oils are recommended for the best engine performance. However, other high-quality detergent oils are permitted if they are classified for service SF, SG, SH, SJ, or higher. Do not use special additives.

Outdoor temperatures determine the required engine oil viscosity. Select the best oil viscosity for the expected outdoor temperature range. Use the following chart as a guide:

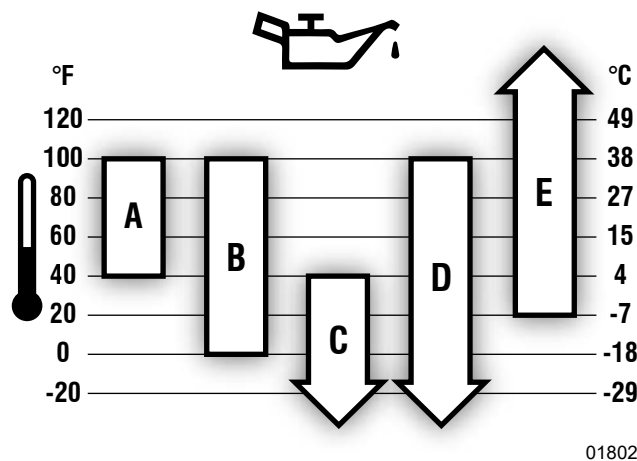

A	SAE 30 – Below 40 °F (4 °C) the use of SAE 30 results in hard starting.
B	10W-30 – Above 80 °F (27 °C) the use of 10W-30 may cause increased oil consumption. Check the oil level frequently.
C	5W-30
D	Synthetic 5W-30
E	Vanguard® Synthetic 15W-50

9.2.3 Engine Fuel

For complete fuel information and use at high altitudes, see the engine manufacturer's manual.

Fuel must meet the following specifications:

- Clean, fresh, unleaded gasoline.
- Minimum of 87 octane / 87 AKI (91 RON).
- Gasoline with up to 10% ethanol (gasohol) is acceptable if the fuel is fresh (less than three months old).

If the machine will be in storage for longer than three months, replace the fuel with one of the following fuel types:

- An alkylate fuel
- An engineered fuel that is high octane, ethanol-free, and formulated with power detergent to prevent the buildup of insoluble solids (deposits).

For instructions, see *Replace the Engine Fuel* on page 54.

9.2.4 Grease

Use an SAE multi-purpose high temperature grease with extreme pressure (EP) performance. An SAE multipurpose lithium-based grease is an acceptable substitute.

9.2.5 Hydraulic Fluid

Use Dexron® III automatic transmission fluid (ATF) for all operating conditions.

The following ATFs are acceptable substitutes:

- Dexron VI
- Mercon®

9.3 Maintenance Schedule

IMPORTANT! For more information, see the engine manufacturer's manual.

Complete maintenance tasks at the specified time or hour interval, whichever comes first.

Task	8 hours or daily	50 hours or annually	100 hours or annually	200 hours or annually	Annually	600 hours or every three years	Reference
Check the winch rope condition.	●						See page 61
Check the hydraulic hoses, fittings, and frame slide.	●						N/A ¹
Check the hydraulic fluid level.	●						See page 31
Check the engine oil level and quality.	●						See page 29
Check the engine fuel level.	●						See page 28
Clean around the muffler and controls.	●						See the engine manual
Clean the engine air-intake grille.	●						N/A
Check that all fasteners are tightened to the specified torque.	●						See page 65
Check that the wheel lug nuts are tightened to the specified torque.	●						See page 66
Grease the machine.		●					See page 59
Check the hydraulic fluid quality.		●					See page 31
Check the tire pressure.			●				See the tire sidewall.
Change the hydraulic fluid and filter.			●				See page 60
Clean the machine. Remove debris and entangled material.			●				N/A
Service the engine exhaust system.			●				See the engine manual
Clean the engine air filter. ²				●			See page 61
Change the engine oil.				●			See the engine manual
Replace the engine spark plug.					●		See the engine manual
Service the engine cooling system.					●		See the engine manual
Service the engine fuel system.					●		See the engine manual
Replace the engine air filter.						●	See page 61

¹ N/A indicates that a reference is not applicable.

² In dusty conditions or when airborne debris is present, clean more often.

9.4 Grease Points

- Use a hand-held grease gun for all greasing.
- Wipe each grease fitting with a clean cloth before greasing to avoid injecting dirt and grit.
- Replace or repair broken fittings immediately.
- If a fitting does not take grease, remove and clean the fitting thoroughly. Also, clean the lubricant passageway. If required, replace the fitting.

Location	Grease Points – Every 50 hours or annually
1	Lower RH and LH side of the log stabilizer
2	Upper RH and LH side of the log stabilizer
3	Winch (two locations)
4	Push block frame slide
5	Wedge height adjustment-arm bushing

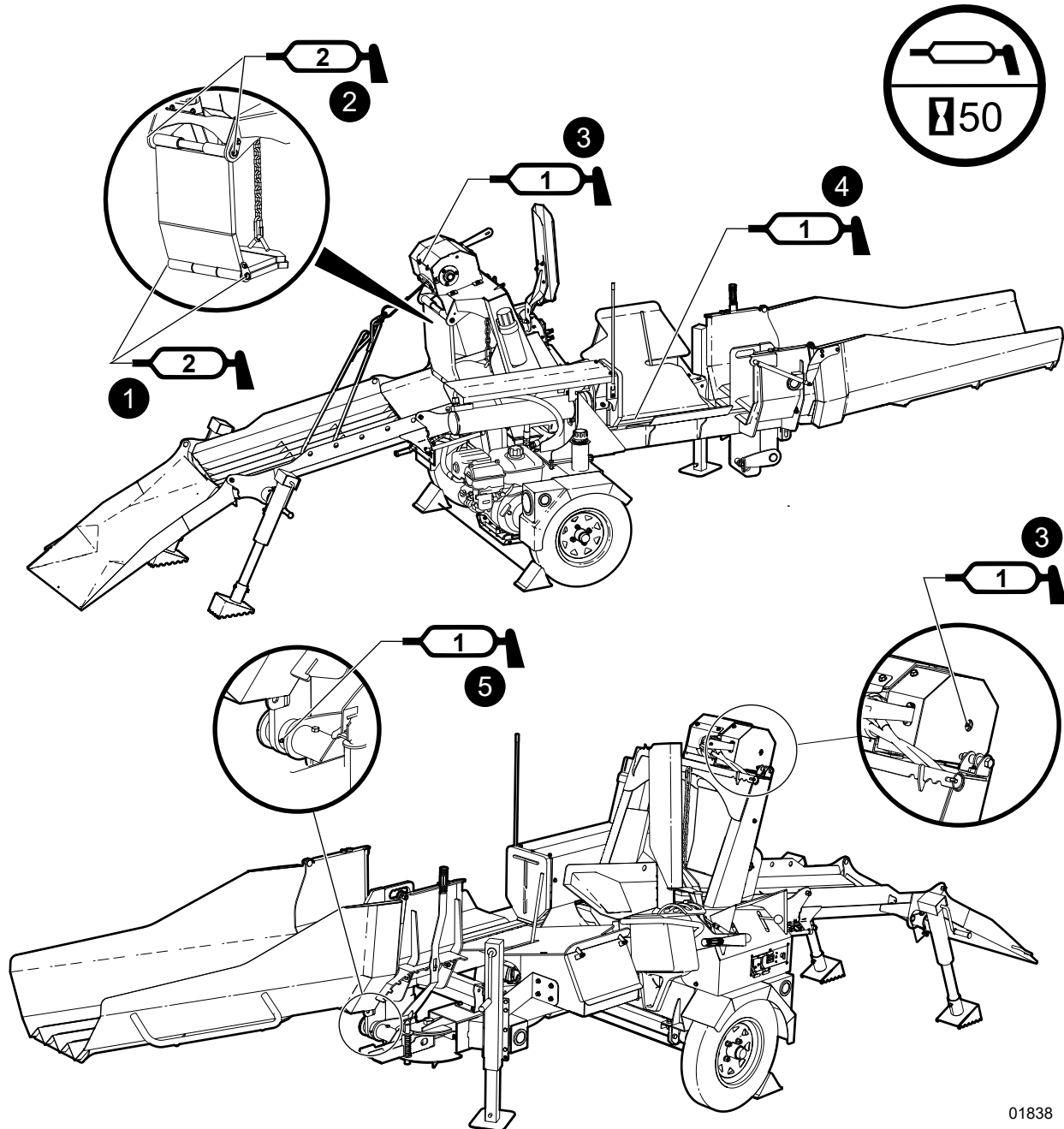

01838

Fig. 54 – Grease points

9.5 Change the Hydraulic Fluid and Filter

CAUTION!



Risk of burns to exposed skin. Hydraulic fluid gets hot during operation, which makes hoses, lines, and other parts hot as well. Wait for the fluid and components to cool before starting maintenance or service.

Change the hydraulic fluid and filter every 100 hours of operation or annually.

Wait for the machine to cool down before changing the hydraulic fluid. However, it is best to change the fluid while the machine is warm to keep any contaminants in suspension.

The filter is located on the back, LH side of the hydraulic-fluid reservoir.

1. Set the machine to a safe condition.
For instructions, see *Safe Condition* on page 9.
2. Place a drain pan under the fluid filter.
Make sure the drain pan is large enough to collect and contain the hydraulic fluid that will drain from the filter and reservoir.
3. Remove the bottom hose and strainer to drain the fluid.
4. Wait for the hydraulic fluid to fully drain from the reservoir.
5. Remove the fluid filter. A filter wrench may be required.
6. Apply a light coat of clean lubricant to the seal, and then install the new filter. Only tighten it by hand, and then tighten it another half turn.
7. Install and secure the strainer and bottom hose.
8. Fill the reservoir with Dexron III ATF or an acceptable substitute. **The reservoir capacity is 6.8 US gal (26 L).**
For more information, see *Add Hydraulic Fluid to the Reservoir* on page 31.
9. Start the machine.
For instructions, see *Start the Machine* on page 32.
10. Advance and retract the push block for 1–2 minutes to remove air from the hydraulic system.
11. Check the fluid filter for leaks.
12. Stop the machine.
For instructions, see *Stop the Machine* on page 32.

13. Check the hydraulic fluid level. Add fluid, as required.
For instructions, see *Check the Hydraulic Fluid Level* on page 31.
14. Dispose of the used hydraulic fluid in an environmentally safe manner.

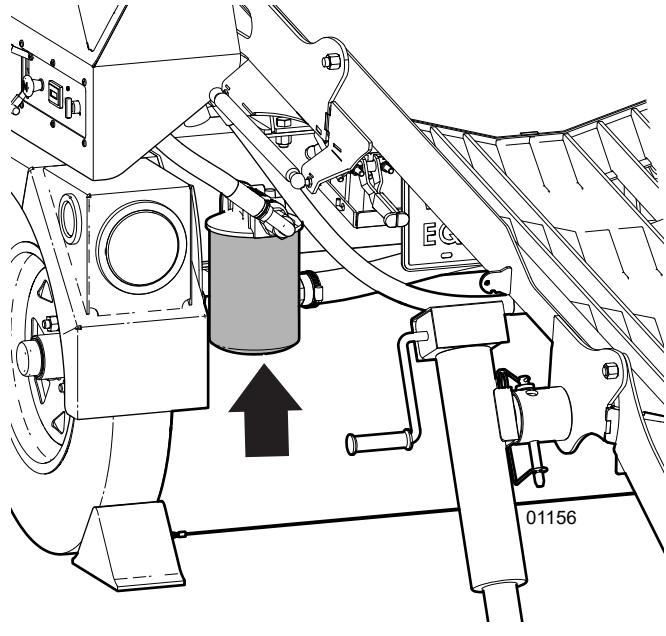

Fig. 55—Hydraulic fluid filter

9.6 Clean the Engine Air Filter

IMPORTANT! Operating the engine without an air filter, or with a damaged air filter, can allow dirt to enter the engine, causing rapid engine wear. This type of damage is not covered by warranty.

Clean the air filter every 200 hours of operation or annually.

A dirty air filter can restrict air flow to the carburetor, reducing the engine performance. If the engine is operated in very dusty areas, clean the air filter more often than specified.

1. Loosen the two air-filter cover fasteners.
2. Remove the cover.
3. Remove the air filter.
4. Gently tap the air filter on a hard surface to loosen and remove dust and debris.
If the air filter is excessively dirty or damaged, replace it with a new air filter.
5. Install the air filter in the engine.
6. Install the cover.
7. Tighten the two air-filter cover fasteners.

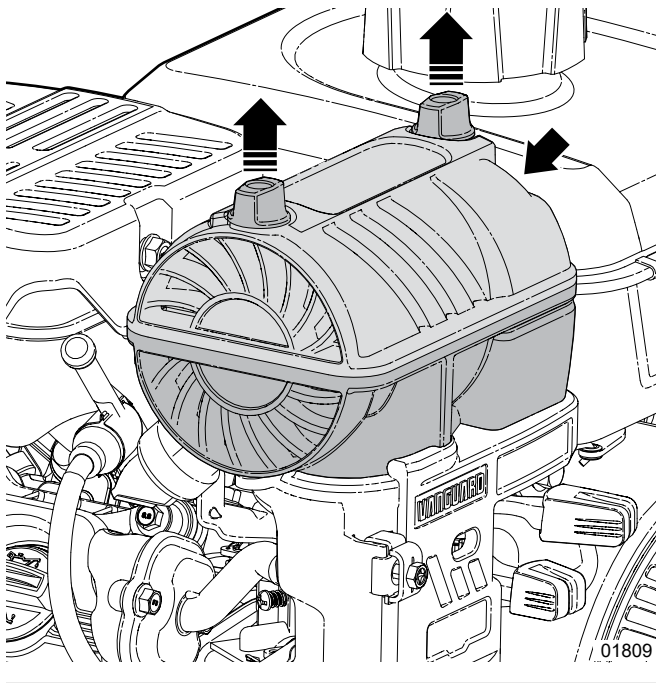

Fig. 56—Engine air filter

9.7 Winch Rope Maintenance

CAUTION!

The wood processor winch is designed to use synthetic rope. Use synthetic rope as replacement only. Failure to do so creates an unsafe work environment and voids warranty.

W079

CAUTION!

Replace a synthetic winch rope with the correct type of synthetic rope. Use of an incorrect type of synthetic rope can result in the rope breaking and causing personal injury. For information about the correct replacement synthetic winch rope, see the Wallenstein Equipment Parts Manual.

W094

9.7.1 Inspect the Winch Rope

IMPORTANT! Heat and exposure to ultra-violet (UV) light break down the fibers of synthetic rope, which weakens the rope and makes it brittle over time. Frequent use in mud, dirt, and sandy conditions can also damage a synthetic rope if it is not thoroughly cleaned and cared for.

Check the entire winch rope for wear and re-spool it neatly (under tension) after every use. Check the winch rope for any cut strands, fraying parts, abrasion, or heat damage from the winch. After some use, all winch ropes get a little fuzzy from abrasion. This is normal. However, **if an entire strand is cut, the winch rope must be replaced or repaired.** All strands must be intact for the winch rope to work properly and maintain its strength.

9.7.2 Clean the Winch Rope

When dirt and grit become lodged between the strands of the winch rope, they cause abrasion to the fibers when the winch rope operates under load. Over time, this can cause the winch rope to lose integrity and strength.

1. Unspool and remove the entire rope from the winch.
1. Lay the rope on a clean surface.
2. Use a water hose to rinse the rope.
3. To remove dirt and grit from the strands:
 - Fill a bucket with water and mild soap.
 - Place the rope in the bucket.
 - Lay a clean towel beside the bucket to place the clean portion of the rope on.

- Starting at one end of the rope, push the rope strands together to open them up and rinse between them.
 - Work your way through the entire rope until the clean rope is laying on the towel.
 - Inspect the winch spool and fairlead for sharp or rough surfaces that could damage the rope. If required, remove or repair sharp or rough surfaces.
4. Dry the rope.
 5. Wind the rope neatly (under tension) onto the winch.

9.8 Tire Maintenance

WARNING!

Failure to follow the proper procedures when mounting a tire on a wheel or rim can produce an explosion, which may result in serious injury or death. Do not attempt to mount a tire unless you have the correct equipment and experience. Have a qualified tire dealer or repair service perform tire maintenance.

IMPORTANT! Replace worn tires with tires that meet the original tire specifications. Never undersize tires.

Check the tire pressure every 100 hours of operation or annually.

- Tighten the wheel lug nuts to the correct torque daily. For torque specifications, see *Wheel Lug Nut Torque* on page 66.
- Check the tire pressure before towing the machine on a roadway. See the tire sidewall for the correct pressure.

10. Troubleshooting



WARNING!

Before troubleshooting, read and understand the *Service and Maintenance Safety on page 56.* Set the machine to a safe condition.

The following table lists some of the problems that you may encounter and provides possible causes and solutions.

If you encounter a problem that is difficult to solve, even after reading this information, please contact your local dealer, the distributor, or Wallenstein Equipment. Before you call, please have the serial number for your product handy.

To find the serial number on your machine, see *Serial Number Location on page 5.*

For engine troubleshooting, see the engine manufacturer's manual.

Problem	Possible cause	Solution
Engine is difficult to start or performance is reduced.	Engine fuel. Not all fuel is the same.	Change the fuel provider or brand.
Winch motor does not move.	Rope is jammed.	Disengage the winch gear, pull the rope out, and then carefully guide the rope, while it retracts onto the spool under load.
Winch rope does not pull out.	Winch gear is engaged.	Disengage the winch gear.
Winch rope does not retract.	Winch gear is disengaged.	Engage the winch gear.
Cylinder rod moves slowly or does not move.	Wood is jammed around the wedge.	Set the machine to a safe condition, and then remove the wood. For instructions, see <i>Safe Condition on page 9.</i>
Cylinder rod or winch motor moves slowly or does not move.	No hydraulic fluid pressure because the fluid filter is plugged.	Change the hydraulic fluid filter. For instructions, see <i>Change the Hydraulic Fluid and Filter on page 60.</i>
	No hydraulic fluid pressure because the hydraulic fluid is low.	Add hydraulic fluid. For instructions, see <i>Add Hydraulic Fluid to the Reservoir on page 31.</i>
	Low hydraulic pressure. The relief setting may be low.	Contact a technician.
	Low engine speed.	Make sure the choke is Closed and the throttle is set to Fast . For information, see <i>Engine Control Panel on page 20.</i>
Control lever does not go to neutral after the cylinder rod is fully advanced or retracted.	Detent is set too tight.	Contact a technician. The valve detent requires adjustment.
	Hydraulic fluid is too cold.	Wait for the machine to warm up.
	Hydraulic fluid is old or contaminated.	Change the hydraulic fluid and filter. For instructions, see <i>Change the Hydraulic Fluid and Filter on page 60.</i>
Control lever goes to neutral before the cylinder rod is fully advanced or retracted.	Detent is set too loose.	Contact a technician. The valve detent requires adjustment.
Control lever does not go to neutral when released.	Control is damaged.	Call a technician. The control requires service or replacement.
Cylinder stops on contact with wood.	Second pump stage is not functioning.	Call a technician. The pump requires service or replacement.
Hydraulic hose leak.	Hose is worn or damaged or a fitting is not secure.	Replace the hose or secure the fitting. If required, replace the fitting.
Cylinder is leaking.	Seals are worn.	Call a technician. The cylinder requires service or replacement.

11. Specifications

For engine specifications, see the engine manufacturer's manual.

11.1 Machine Specifications¹

Model	WP845	WP875
Engine make / displacement / horsepower	Vanguard® / 408 cc / 14 hp	
Hydraulic pump flow / type	22 US gpm (83.2 Lpm) / 2 stage	
Cylinder diameter / stroke	4.50" / 25.75" (121 mm / 654 mm)	4.50" / 37.75" (121 mm / 959 mm)
Splitter control valve type	Dual-valve open center with Auto-Cycle detent	
Full-stroke splitting cycle time	8.2 seconds	12 seconds
Split force	25 ton	
Maximum split length	27" (69 cm)	39" (99 cm)
Maximum log diameter	22" (56 cm)	
Wedge configuration	Adjustable 4-way	
Suspension	Torflex® suspension	
Tire size / type	5.30 x 12.00 / highway	
Ball-hitch size	2" (50 mm) ball coupler and safety chains	
Trailer light package	Highway lights and cable	
Weight	2,035 lb (923 kg)	2,273 lb (1 031 kg)
Dimensions: unfolded (L x W x H)	220" x 60" x 66" (559 cm x 152 cm x 168 cm)	244" x 60" x 66" (620 cm x 152 cm x 168 cm)
Dimensions: folded (L x W x H)	126" x 60" x 79" (320 cm x 152 cm x 201 cm)	161" x 60" x 79" (409 cm x 152 cm x 201 cm)
Winch type	Hydraulic, valve-operated	
Winch rope length	50' (15.2 m)	
Winch pulling capacity	1,550 lb (703 kg)	
Maximum splitter chute height	54" (1.4 m)	
Hydraulic fluid reservoir capacity	6.8 US gal (26 L)	
Winch strap length	60" (1,5 m)	
Accessories	Adjustable 6-way wedge	
	Nylon chain-saw holster	
	48" (1.2 m) log peavey	
	Firewood net frame	
	Firewood net	
	Spare universal chain-saw adaptor	

¹ Specifications are subject to change without notice

11.2 Common Bolt Torque

Checking Bolt Torque

The tables shown give correct torque values for various bolts and capscrews. Tighten all bolts to the torque values specified in the table, unless indicated otherwise. Check tightness of bolts periodically.

IMPORTANT! If replacing hardware, use fasteners of the same grade.

IMPORTANT! Torque figures indicated in the table are for non-greased or non-oiled threads. Do not grease or oil threads unless indicated otherwise. When using a thread locker, increase torque values by 5%.



Bolt grades are identified by their head markings.

Imperial Bolt Torque Specifications						
Bolt Diameter	Torque Value					
	SAE Gr. 2		SAE Gr. 5		SAE Gr. 8	
	lbf•ft	N•m	lbf•ft	N•m	lbf•ft	N•m
1/4"	6	8	9	12	12	17
5/16"	10	13	19	25	27	36
3/8"	20	27	33	45	45	63
7/16"	30	41	53	72	75	100
1/2"	45	61	80	110	115	155
9/16"	60	95	115	155	165	220
5/8"	95	128	160	215	220	305
3/4"	165	225	290	390	400	540
7/8"	170	230	420	570	650	880
1"	225	345	630	850	970	1320



SAE Gr. 2



SAE Gr. 5



SAE Gr. 8

Metric Bolt Torque Specifications				
Bolt Diameter	Torque Value			
	Gr. 8.8		Gr. 10.9	
	lbf•ft	N•m	lbf•ft	N•m
M3	0.4	0.5	1.3	1.8
M4	2.2	3	3.3	4.5
M6	7	10	11	15
M8	18	25	26	35
M10	37	50	52	70
M12	66	90	92	125
M14	83	112	116	158
M16	166	225	229	310
M20	321	435	450	610
M30	1,103	1 495	1,550	2 100



8.8



10.9

11.3 Hydraulic Fitting Torque

Tightening Flare Type Tube Fittings

1. Check flare and flare seat for defects that might cause leakage.
2. Align tube with fitting before tightening.
3. Hand-tighten swivel nut until snug.
4. To prevent twisting the tube, use two wrenches. Place one wrench on the connector body and tighten the swivel nut with the second. Torque to values shown.

If a torque wrench is not available, use the FFFT (Flats From Finger Tight) method.

Hydraulic Fitting Torque					
Tube Size OD	Hex Size Across Flats	Torque value		Flats From Finger Tight	
		lbf•ft	N•m	Flats	Turns
3/16	7/16	6	8	2	1/6
1/4	9/16	11–12	15–17	2	1/6
5/16	5/8	14–16	19–22	2	1/6
3/8	11/16	20–22	27–30	1-1/4	1/6
1/2	7/8	44–48	59–65	1	1/6
5/8	1	50–58	68–79	1	1/6
3/4	1-1/4	79–88	107–119	1	1/8
1	1-5/8	117–125	158–170	1	1/8

Values shown are for non-lubricated connections.

11.4 Wheel Lug Nut Torque



Loose wheel lug nuts can result in broken studs, risking the wheel coming off the axle hub. Keep lug nuts torqued to proper specification.

Maintaining proper wheel lug torque on your trailer axle is an extremely important safety measure. Always use a properly calibrated torque wrench.

Torque wheel lug nuts before first road use and after each wheel removal. Check and re-torque after the first 10 mi (16 km), 25 mi (40 km), and again at 50 mi (80 km). Check periodically thereafter.

- Start all lugs by hand to prevent cross threading.
- Tighten lug nuts following the Wheel Lug Torque Pattern. Tighten each set of lug nuts in stages, as shown.

Wheel Lug Nut Torque				
Wheel Size	Units	1st Stage	2nd Stage	3rd Stage
8"	lbf•ft N•m	12–20 16–26	30–35 39–45.5	45–55 58.5–71.5
12"	lbf•ft N•m	20–25 26–32.5	35–40 45.5–52	50–60 65–78
13"	lbf•ft N•m	20–25 26–32.5	35–40 45.5–52	50–60 65–78
14"	lbf•ft N•m	20–25 26–32.5	50–60 65–78	90–120 117–156
15"	lbf•ft N•m	20–25 26–32.5	50–60 65–78	90–120 117–156
16"	lbf•ft N•m	20–25 26–32.5	50–60 65–78	90–120 117–156

Wheel Lug Torque Pattern

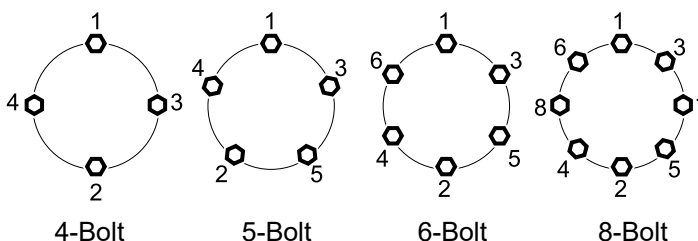

12. Product Warranty



LIMITED WARRANTY

Wallenstein products are warranted to be free of defects in materials and workmanship under normal use and service, for a period of

Five Years for Consumer Use

Two Years for Commercial/Rental Use

from the date of purchase, when operated and maintained in accordance with the operating and maintenance instructions supplied with the unit. Warranty is limited to the repair of the product and/or replacement of parts.

This warranty is extended only to the original purchaser and is not transferable.

Repairs must be done by an authorized dealer. Products will be returned to the dealer at the customer's expense. Include the original purchase receipt with any claim.

This warranty does not cover the following:

- 1) Normal maintenance or adjustments
- 2) Normal replacement of wearable and service parts
- 3) Consequential damage, indirect damage, or loss of profits
- 4) Damages resulting from:
 - Misuse, negligence, accident, theft or fire
 - Use of improper or insufficient fuel, fluids or lubricants
 - Use of parts or aftermarket accessories other than genuine Wallenstein parts
 - Modifications, alteration, tampering or improper repair performed by parties other than an authorized dealer
 - Any device or accessories installed by parties other than an authorized dealer
- 5) Engines. Engines are covered by the manufacturer of the engine for the warranty period they specify. For the details of your engine warranty, see your engine owner's manual. Information about engine warranty and service is also available in the FAQ section at www.wallensteinequipment.com

rev. Nov-2018

13. Index

	A		
Air filter, clean.....		61	
Alert symbol		7	
	B		
Ball-mount hitch			
Connect		52	
Disconnect		53	
Battery, safety		28	
Bolt torque.....		65	
Break-in, machine		26	
	C		
Chain saw			
Attach to holder.....		38	
Cut logs.....		46	
Safety.....		45	
Start		46	
Choke control, engine		20	
Chutes			
Lead-in and log-loader			
Fold up		51	
Unfold		35	
Splitter			
Height adjustment		24	
Set height		36	
Unfold		36	
Components, machine		19	
Controls.....		20	
Auto cycle		21	
Engine.....		20	
Hour meter and RPM display.....		20	
Hydraulic.....		21	
Log-length guide.....		23	
Splitter cylinder extend and retract		21	
Splitting-wedge height adjustment lever		23	
Starter-cord handle		21	
Winch.....		22	
Winch gear lever.....		22	
Cut logs		45	
	D		
Decals			
Informative		6	
Maintenance		6	
Product		6	
Safety notice		6	
Safety sign		6	
Types		6	
Delivery inspection report.....		4	
	E		
Emergency stop		32	
Engine			
Air filter, clean		61	
Controls		20	
Fuel			
Add		29	
Level check		28	
Replace		54	
Specifications		57	
Hour meter and RPM display.....		20	
Oil			
Add		30	
Level check		29	
Specifications		57	
Operation		27	
Safety.....		27	
Starter-cord handle		21	
Equipment safety guidelines		9	
	F		
Familiarization		18	
Machine components.....		19	
New operator		18	
Operator orientation.....		18	
Training.....		18	
Work site.....		18	
Filter			
Engine air, clean		61	
Hydraulic, change		60	
First log, position		43	
Fluid, hydraulic			
Add		31	
Change		60	
Level check.....		31	
Specifications.....		57	
Foreword		3	
Delivery Inspection Report.....		4	
Introduction		3	
Serial number location		5	
Types of decals.....		6	
Fuel, engine			
Add		29	
Level check.....		28	
Replace.....		54	
Specifications.....		57	
	G		
Grease			
Points.....		59	
Specifications.....		57	
Guidelines, equipment safety.....		9	
	H		
Height adjustment			
Splitter chute.....		24	
Splitting wedge		23	
Hour meter, engine.....		20	
Hydraulic			
Controls		21	
Filter, change		60	
Fluid			
Add		31	
Change.....		60	
Level check		31	
Specifications		57	
Safety.....		30	
System operation.....		30	

I		Split logs	47
Ignition switch, engine	20	Split wood discharge	48
Inspection		R	
Dealer report	4	Replace engine fuel	54
Delivery report	4	Replace safety signs	17
Instructions, operating	25	RPM display, engine	20
Introduction	3	Rules, safety	8
L		S	
Last log, position	48	Safe condition	9, 56
Lead-in chute		Safety	7
Fold up	51	Alert symbol	7
Unfold	35	Battery	28
Log-length guide	23	Chain saw	45
Set	37	Create a safe work area	11
Log-loader chute		Decals	6
Fold up	51	Engine	27
Unfold	35	Equipment guidelines	9
Lubricants, handling and storage	57	Hydraulic system	30
M		Operation	25
Maintenance. See Service and maintenance		Rules	8
N		Service and maintenance	56
New operator	18	Signal words	7
Next log, position	48	Storage	54
O		Training	9
Oil, engine		Transport	49
Add	30	Winch	40
Level check	29	Work area	11
Specifications	57	Safety signs	12
Operation	25	Explanations	15
Cut logs	45	Locations	13
Emergency stop	32	Replace	17
Engine	27	Schedule, maintenance	58
Hydraulic system	30	Serial number location	5
Instructions	25	Service and maintenance	56
Machine break-in	26	Filters	
Position		Engine air, clean	61
First log	43	Hydraulic, change	60
Last log	48	Fluids and lubricants	57
Next log	48	Grease points	59
Pre-start checklist	26	Hydraulic fluid change	60
Process logs	32	Maintenance schedule	58
Safety	25	Safety	56
Setup, machine	33	Tire maintenance	62
Split logs	47	Winch rope maintenance	61
Split wood discharge	48	Setup	
Start machine	32	Chain saw, attach holder	38
Stop machine	32	Lead-in and log-loader chutes, unfold	35
Winch	42	Log-length guide, set	37
Operator		Machine	33
New	18	Splitter chute	
Orientation	18	Set height	37
P		Unfold	36
Pre-start checklist	26	Splitting wedge height, set	37
Process logs	32	Tow vehicle, disconnect	53
Cut logs	45	Shutoff, engine fuel	20
Position the first log	43	Signal words	7
Position the last log	48	Sign-off form, training	10
Position the next log	48	Specifications	64
R		Fluid, hydraulic	57
L		Fuel, engine	57
M		Grease	57
N			
O			

Machine	64
Oil, engine.....	57
Torque	
Common bolt.....	65
Hydraulic fitting.....	66
Wheel lug nuts.....	66
Split logs.....	47
Splitter chute	
Set height.....	36
Unfold	36
Splitting wedge	
Height adjustment lever	23
Set height.....	37
Split wood discharge.....	48
Standards.....	10
Start a chain saw.....	46
Starter-cord handle, engine.....	21
Start machine	32
Stop machine	32
Emergency.....	32
Storage.....	54
Place machine	54
Remove machine.....	54
Replace engine fuel.....	54
Safety.....	54

T

Throttle control, engine	20
Tire maintenance	62
Tow vehicle, attach machine	52
Trailer jack	
Lower.....	53
Stow.....	53
Trailer tongue, pivot	52
Training	
Familiarization.....	18
Safety.....	9
Sign-off form	10
Transport	
Fold up chutes	51
Prepare the machine	49
Safety.....	49
Tow vehicle, attach	52
Troubleshooting	63
Types of decals	6

W

Warranty.....	67
Wheel lug nut torque.....	66
Winch	
Control	22
Gear lever.....	22
Operation.....	40
Rope maintenance and replacement.....	61
Safety.....	40
Work area, create a safe.....	11
Work site familiarization	18



A series of 20 horizontal lines spanning the width of the page, providing a template for writing.



MAKING WORK FEEL MORE LIKE PLAY™

WallensteinEquipment.com

