



# FX90 Skidding Winch Parts Manual

S/N 590456 to S/N 590641



# Foreword

EMB Mfg. has prepared this parts manual to assist customers in ordering quality OEM replacement parts.

Proper and regular service and replacing old, worn or broken parts with the correct Wallenstein parts are essential to prolonging the life of your Wallenstein product. Please refer to this manual before ordering any replacement parts.

All information contained in this parts manual is based on the latest product specification available at the time of printing this manual. If your product differs from the specifications contained within this manual contact EMB Mfg. for information.

EMB reserves the right to alter specifications on their products at any time.

Reproduction of this parts manual of any kind is prohibited without prior written permission from EMB Mfg.

**Note:** Products with factory installed light kits will have a VIN number included. The last six numbers of this VIN number are the splitters serial number

Example: 2E9US1112BSXXXXXX

# Table of Contents

Main Parts	5
Lower Snatch Block	6
Top Cable Pulley	7
Drum Frame	8
Cable Drum	9
PTO Shaft	10
Decal Breakdown	12

This Page is Intentionally Blank

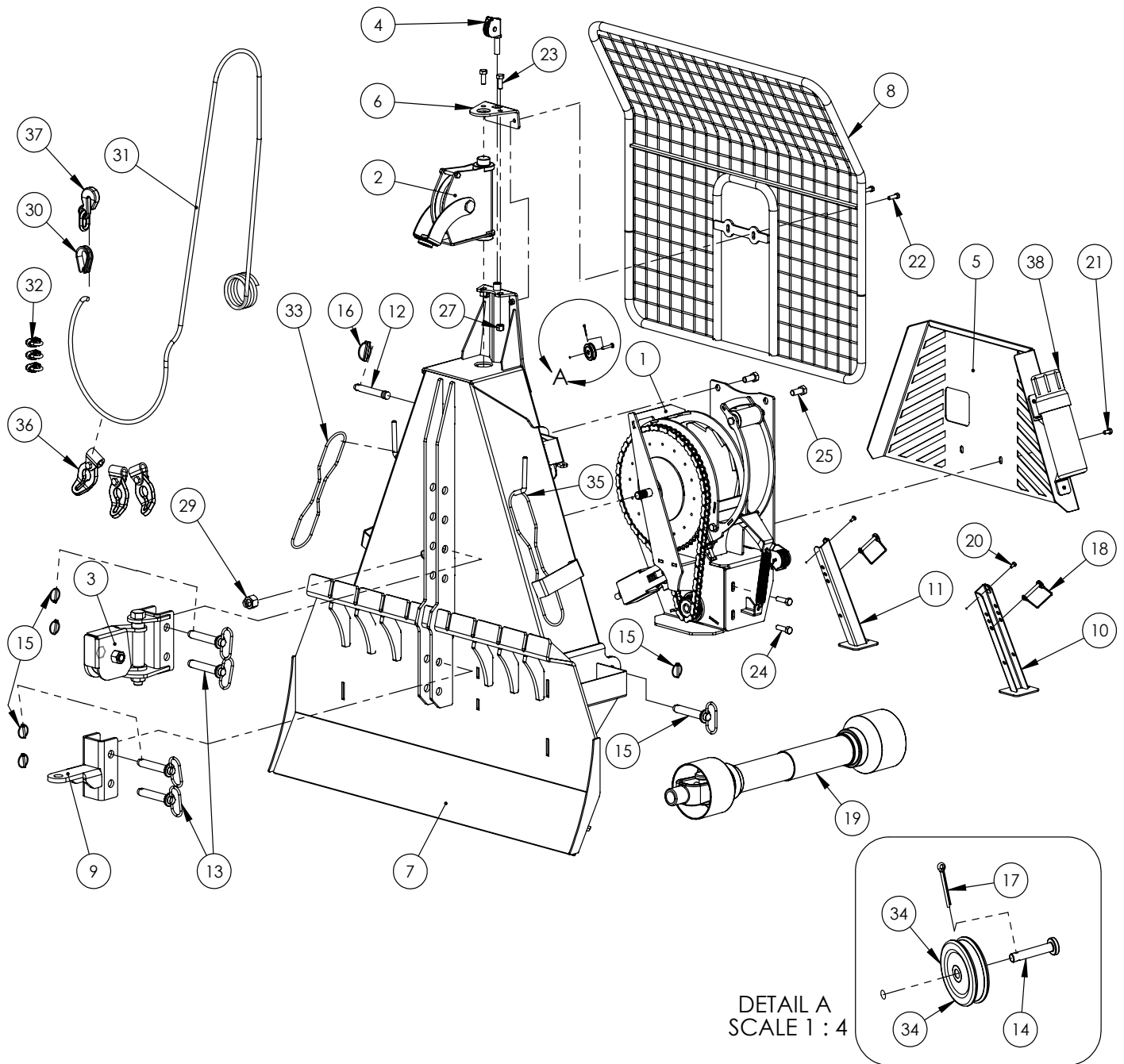

**FX90 MAIN ASSEMBLY PARTS BREAKDOWN**

ITEM	PART NO.	DESCRIPTION	QTY
1	5012A201	Cable Drum Assembly	1
2	5012A205	Top Cable Pulley Assembly	1
3	5012A206	Lower Snatch Block	1
4	5012A207	Clutch Rope Pulley	1
5	5012L284	Lower Protective Shield	1
6	5012L285	Top Pulley Capture Bracket	1
7	5012W201	Main Frame	1
8	5012W214	Safety Screen	1
9	5012W216	Hitch	1
10	5012W217	Support Leg, RH	1
11	5012W218	Support Leg, LH	1
12	Z11122	Toplink Pin 3/4 x 3-7/8	1
13	Z11251	Hitch Pin 7/8 x 4-1/4	6
14	Z11311	Clevis Pin 1/4 x 1-1/8	1
15	Z12110	Latch Pin 3/16	6
16	Z12140	Latch Pin 7/16	1
17	Z12311	Cotter Pin 1/8 X 1	1
18	Z12432	Snapper Pin 3/8 x 2-1/2	2
19	Z44401	#4 PTO Shaft M8 Shear	1

ITEM	PART NO.	DESCRIPTION	QTY
20	Z71105	Hex Bolt 1/4NC x 1/2	2
21	Z71307	Hex Bolt 3/8NC x 3/4	2
22	Z71312	Hex Bolt 3/8NC x 1-1/4	2
23	Z71512	Hex Bolt 1/2NC x 1-1/4	2
24	Z71517	Hex Bolt, 1/2NC x 1-3/4	2
25	Z71615	Hex Bolt 5/8NC x 1-1/2	2
26	Z72231	Hex Lock Nut 3/8NC	2
27	Z72251	Hex Lock Nut 1/2NC	4
28	Z72261	Hex Lock Nut 5/8NC	2
29	Z72281	Hex Lock Nut 7/8NC	1
30	Z92105	Thimble, Cable Protector	1
31	Z92111	Winch Cable 7/16 x 165'	1
32	Z92113	7/16 Cable Clamp	3
33	Z92201	Clutch Control Rope	1
34	Z92203	1/4 Groove Pulley 2 Diam.	1
35	Z92205	Drum Brake Rope 18'	1
36	Z92301	Keyhole Slider	3
37	Z92302	Grab Hook	1
38	Z96503	Manual Tube 3-1/2 Short	1

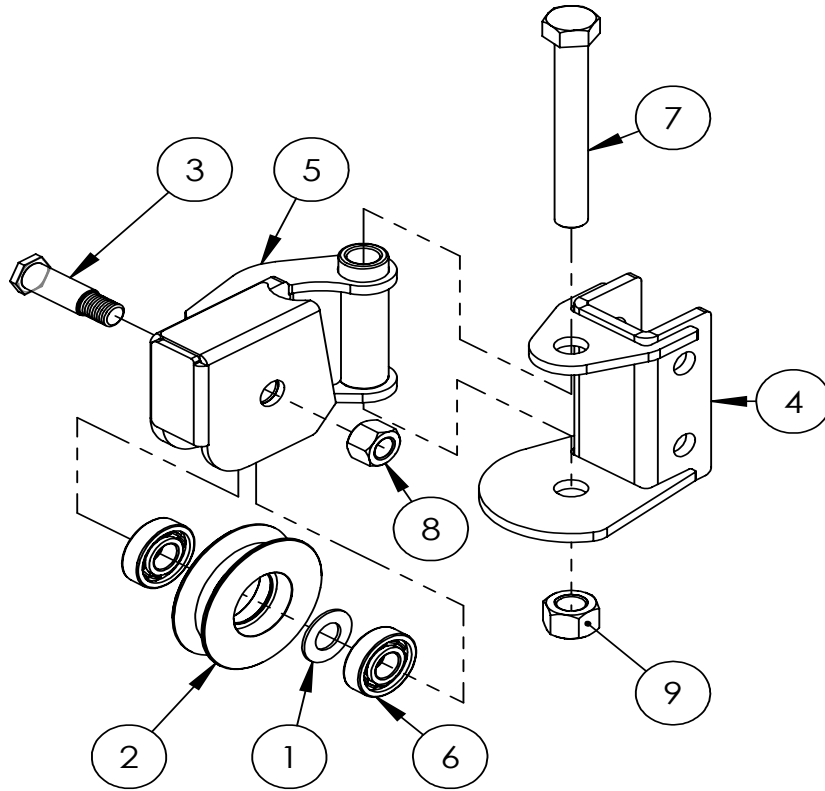

### LOWER SNATCH BLOCK ASSEMBLY

ITEM	PART NO.	DESCRIPTION	QTY
1	5012L264	Washer, Bearing Spacer	1
2	5012M223	Snatch Block Pulley	1
3	5012M224	Snatch Block Pulley Pin	1
4	5012W212	Snatchblock Base	1
5	5012W213	Snatchblock Swivel Housing	1
6	Z21201	Ball Bearing 6305 RS	2
7	Z71915	Hex Bolt 1NC x 8	1
8	Z72281	Hex Lock Nut 7/8NC	1
9	Z72291	Hex Lock Nut 1NC	1

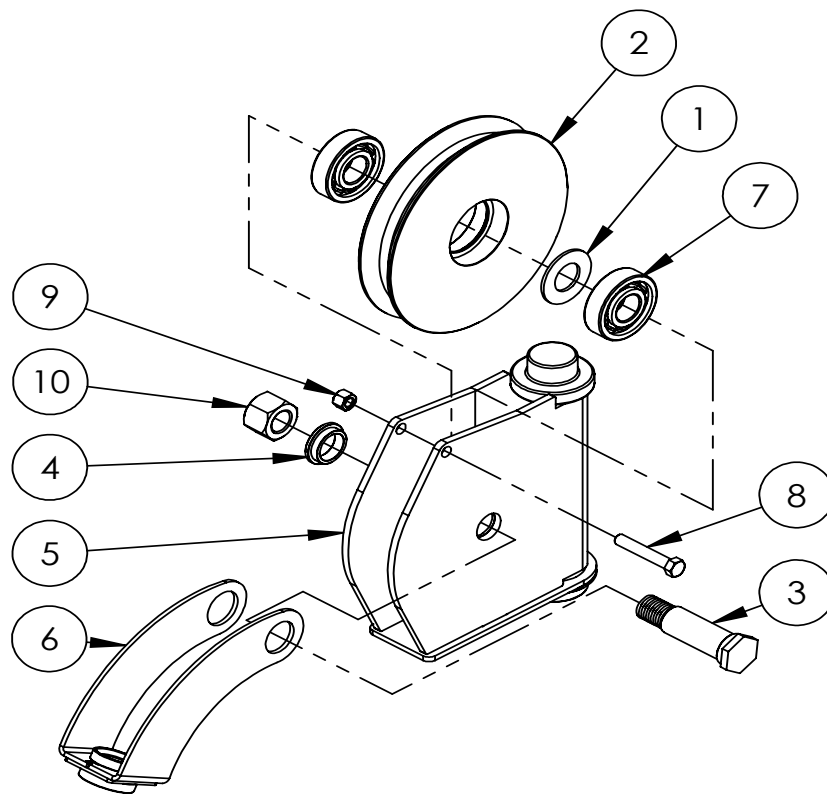

## TOP CABLE PULLEY ASSEMBLY

ITEM	PART NO.	DESCRIPTION	QTY
1	5012L264	Washer, Bearing Spacer	1
2	5012M220	Top Cable Pulley	1
3	5012M221	Top Pulley Pin	1
4	5012M222	Cable Guide Swing Bushing	1
5	5012W210	Top Pulley Housing	1
6	5012W211	Cable Guide	1
7	Z21201	Ball Bearing 6305 RS	2
8	Z71322	Hex Bolt, 3/8NC x 2-1/4	1
9	Z72231	Hex Lock Nut 3/8NC	1
10	Z72281	Hex Lock Nut 7/8NC	1

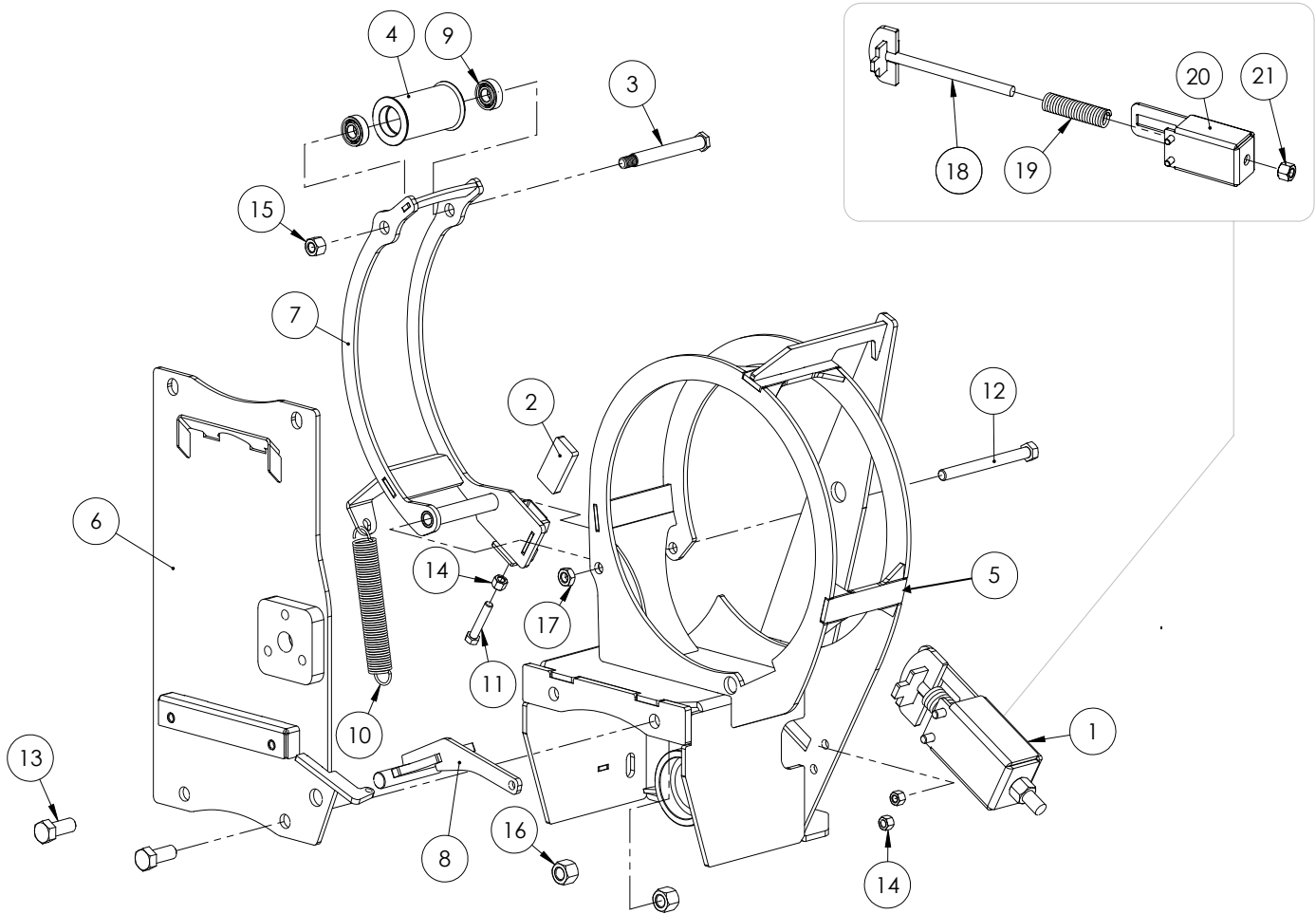

### DRUM FRAME ASSEMBLY

ITEM	PART NO.	DESCRIPTION	QTY
1	5012A203	Single Auto Chain Tightener	1
2	5012M204	Block, Drum Brake	1
3	5012M205	Cable Roller Pin	1
4	5012M206	Brake Arm Cable Roller	1
5	5012W202	Drum Frame Base	1
6	5012W203	Drum Frame Capture Plate	1
7	5012W204	Drum Brake Arm	1
8	5012W206	Lock Dog	1
9	Z21203	Ball Bearing 6202 RS	2
10	Z31403	Spring 25mm x 178mm x 0.105	1
11	Z71320	Hex Bolt 3/8NC x 2	1
12	Z71555	Hex Bolt 1/2NC x 5 1/2	1
13	Z71615	Hex Bolt 5/8NC x 1 1/2	2
14	Z72231	Hex Lock Nut 3/8NC	3
15	Z72251	Hex Lock Nut 1/2NC	1
16	Z72261	Hex Lock Nut 5/8NC	2
17	Z72451	Hex Jam Lock Nut, 1/2NC	1
18	5012W205	Chain Tightener Plunger	1
19	Z32401	Heavy Spring 1 x 7	1
20	5012W221	Chain Tightener Housing	1
21	Z72261	Hex Lock Nut 5/8NC	1



**CLUTCH ASSEMBLY BREAKDOWN**

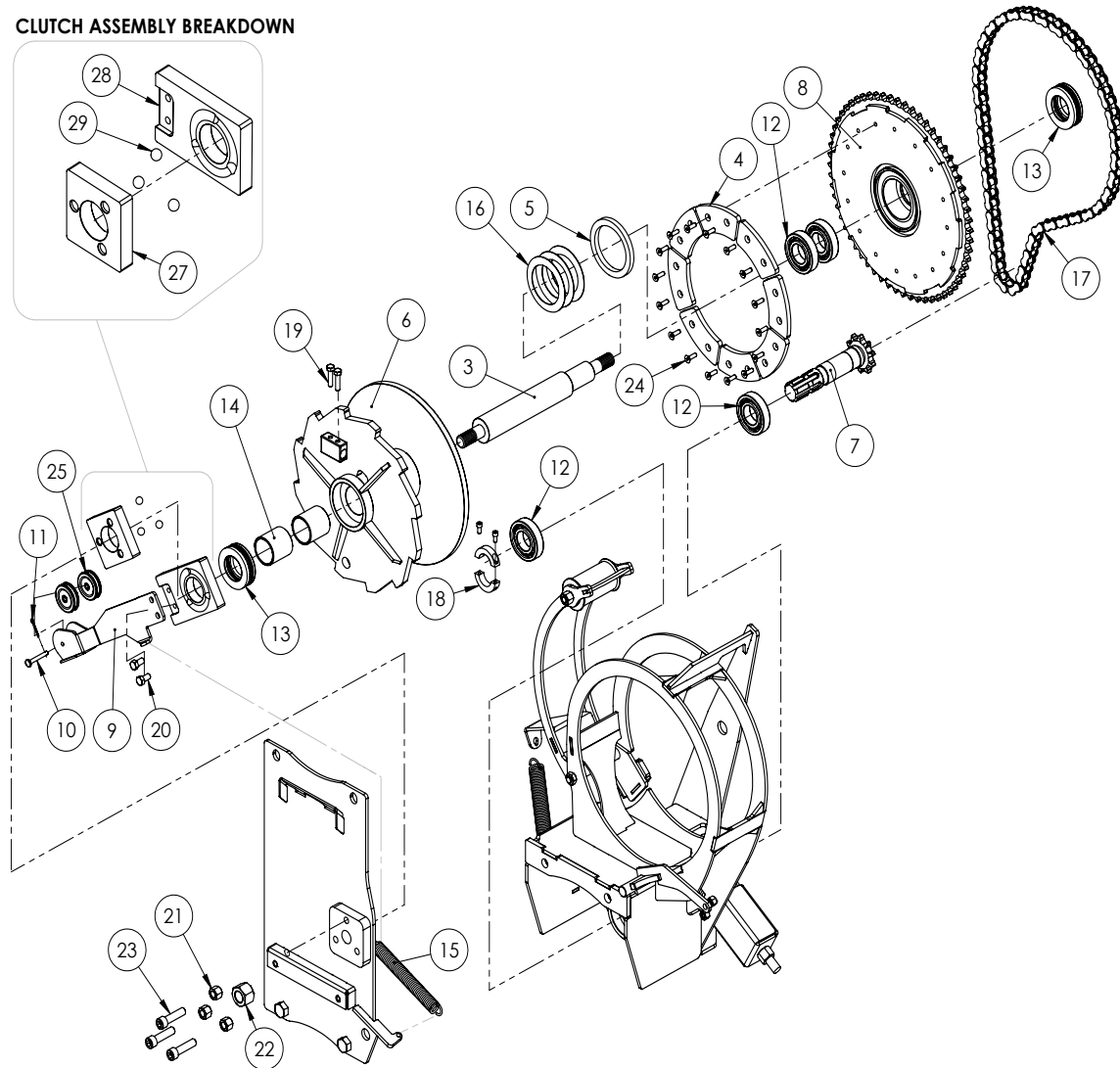

**CABLE DRUM ASSEMBLY**

ITEM	PART NO.	DESCRIPTION	QTY
1	5012A202	Cable Drum Frame	1
2	5012A204	Clutch Assembly	1
3	5012M214	Main Drum Shaft	1
4	5012M215	Clutch Pad Set (8 pieces)	1
5	5012M228	Nylon Bearing Washer	1
6	5012W207	FX90 Cable Drum	1
7	5012W208	PTO Spline Shaft w/ Sprocket	1
8	5012W209	60 Tooth Sprocket	1
9	5012W220	Clutch Lever	1
10	Z11312	Clevis Pin 1/4 x 1-5/8	1
11	Z12311	Cotter Pin 1/8 X 1	1
12	Z21202	Ball Bearing 6207-RS	4
13	Z22101	Thrust Bearing, 1-3/4 Bore	2
14	Z27101	Fiberglide Bearing 1-3/4 x 2	2
15	Z31405	Spring 7/8 x 7 Heavy	1
16	Z34101	Cup Spring, 2-3/4	3
17	Z42151	#6 Chain 76 Links	1
18	Z46311	Clamp-on Shaft Collar	1
19	Z71212	Hex Bolt 5/16NC x 1-1/4	2
20	Z71307	Hex Bolt 3/8NC x 3/4	2
21	Z72252	Hex Lock Nut 1/2NF	3
22	Z72281	Hex Lock Nut 7/8NC	1
23	Z75151	Cap Screw 1/2NF x 2	3
24	Z75211	FHCS, 1/4NC x 7/8	16
25	Z92203	1/4 Groove Pulley 2 Diam.	2
ITEM	PART NO.	DESCRIPTION	QTY
27	5012M212	Clutch Engagment Nut	1
28	5012M213	Clutch, Engagment Block-Handle	1
29	Z29101	Roller Ball, 1/2	3

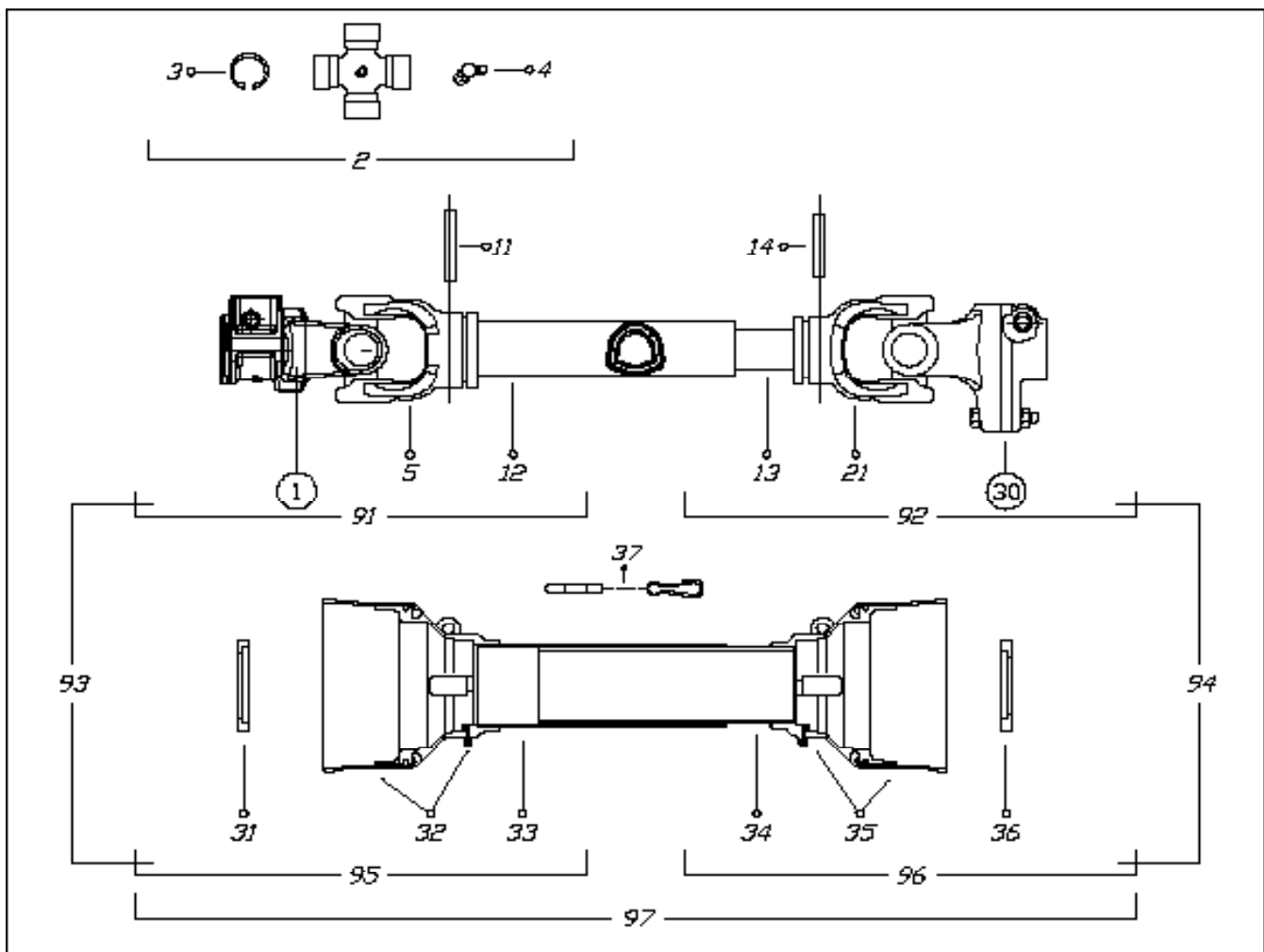

①

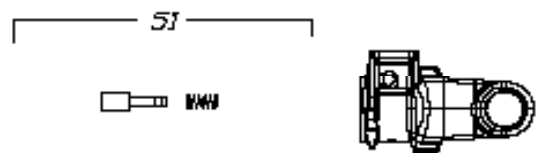

③①

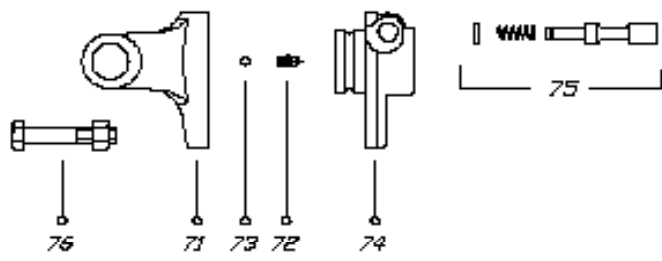

VIETATE LE RIPRODUZIONI NON AUTORIZZATE  
NOT PERMITTED AL RIGHTS RESERVED

TOUTE REPRODUCTION NON AUTORISEE EST INTERDITE  
NICHT GENEHMIGTE VERVIELFÄLTIGUNGEN SIND UNZULASSIG

DOODGE C.E.J.  
B4080EA60098

DATA  
19/02/08

<b>BINACCHI SPARE PARTS LIST : B4080EA60098</b>			
<b>POS.</b>	<b>DESCRIPTION</b>	<b>Q.</b>	<b>Part #</b>
D1	YOKE	1	D800403
D2	CROSS JOURNAL ASS.	2	D8204
D3	CIRCLIP	8	D8802027
D4	GREASE NIPPLE	2	D8840081002
D5	OUTER TUBE YOKE	1	D8004021
11	FLEXIBLE PIN	1	D88700880
12	CM. 100 CARDAN TUBE(*)	1	D8881433100
13	CM. 100 CARDAN TUBE(*)	1	D8881364100
14	FLEXIBLE PIN	1	D88700855
21	INNER TUBE YOKE	1	D8004011
30	SHEAR BOLT LB4	1	D8804
31	OUTER BEARING	1	D285140007
32	OUTER BASIC CONE	1	D258040324
33	OUTER SAFETY TUBE	1	D8888884080
34	INNER SAFETY TUBE	1	D88888184080
35	INNER BASIC CONE	1	D258040325
38	INNER BEARING	1	D285140008
37	CHAIN	1	D252000001
51	COMPLTE PUSH BUTTON	1	D880014047
71	YOKE FOR LB4	1	D880004
72	GREASE NIPPLE	1	D884010150
73	STEEL BALL	23	D88880104
74	HUB	1	D88064A80
75	PUSH PIN SET	1	D880014075
78	NUT AND BOLT	1	D880080508
B1	OUTER HALF SHAFT	1	B4D8002
B2	INNER HALF SHAFT	1	B4D8001088
B3	OUTER HALF SHAFT	1	B4D80E2
B4	INNER HALF SHAFT	1	B4D80E1088
B5	OUTER HALF SAFETY GUARD	1	D83E040802
B8	INNER HALF SAFETY GUARD	1	D83E040801
B7	SAFETY GUARD	1	D83E04080

### FX90 SKIDDING WINCH DECAL BREAKDOWN

ITEM	PART NO.	DESCRIPTION	QTY
1	Z94042	Rotating Driveline Hazard	1
2	Z94019	Made in Canada	3
3	Z94043	Flying Object Hazard	2
4	Z94058	Clutch Adjustment	1
5	Z94041	Read Manual	1
6	Z94001	Wallenstein Skidding Winch	1
7	Z94002	FX90	1

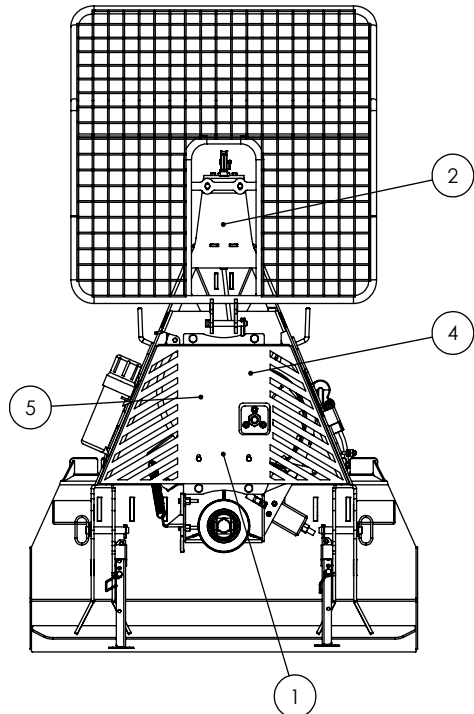
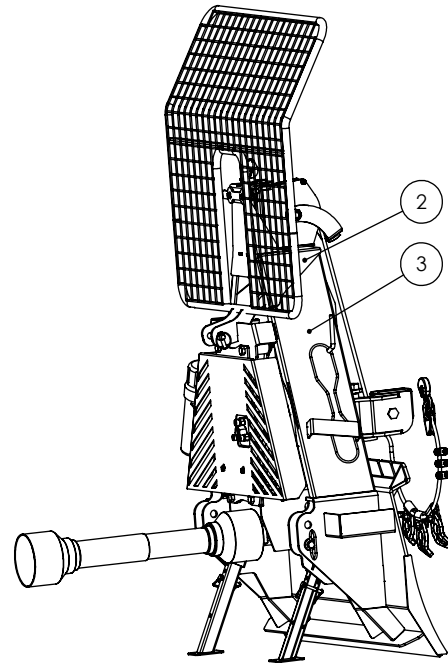
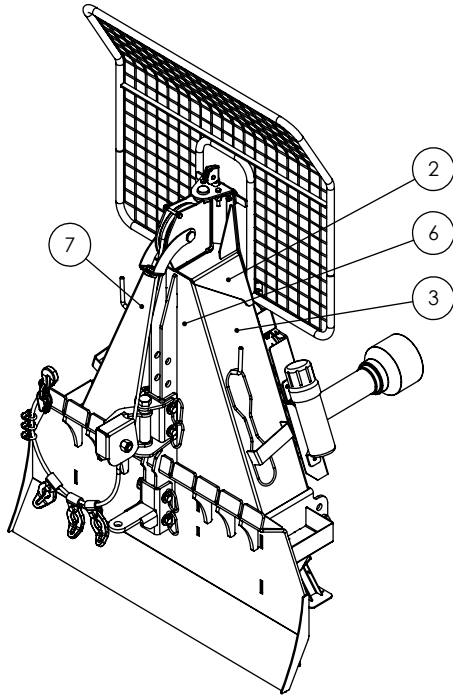

# FX90 Decals

Z94042



Z94058



Z94019



Z94041

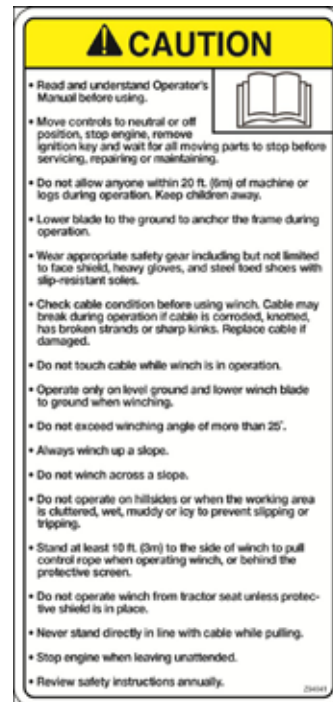

Z94043



Z94002



Z94001



## TWO PANEL FX90 SKIDDING WINCHDECAL BREAKDOWN

ITEM	PART NO.	DESCRIPTION	QTY
1	Z94118	Rotating Driveline Hazard	1
2	Z94019	Made in Canada	3
3	Z94114	Flying Object Hazard	2
4	Z94119	Read Manual	1
5	Z94001	Wallenstein Skidding Winch	1
6	Z94002	FX90	1
7	Z94160	Winch Operation	2
8	Z94161	Max RPM	1

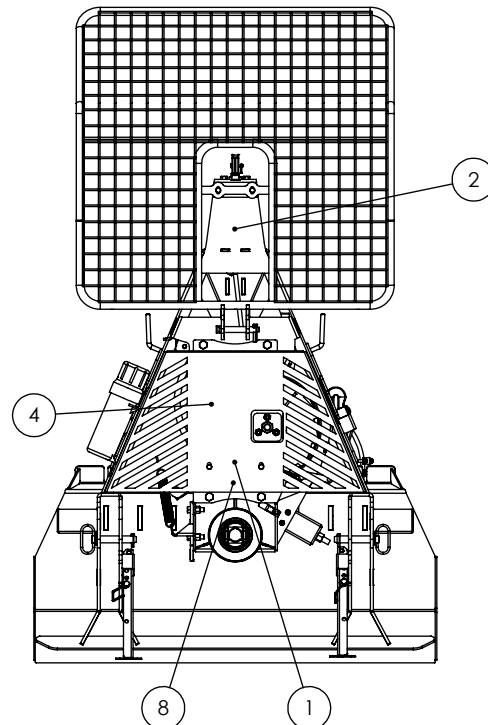
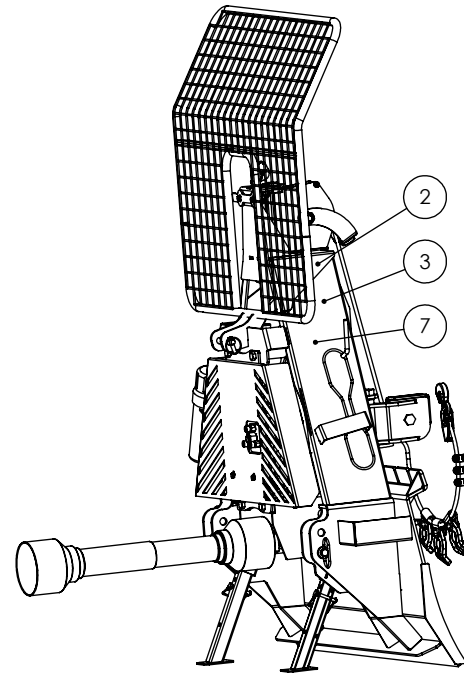
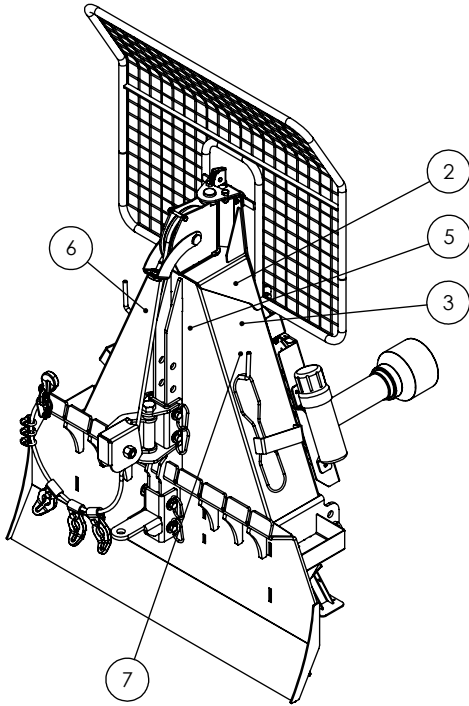

### Two Panel FX90 Decals

Z94161



Z94019



Z94160

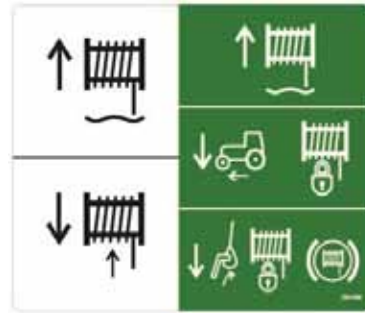

Z94118



Z94119



Z94114



Z94002



Z94001





**WALLENSTEIN Products Manufactured by:**

**EMB MFG Inc.**

4144 Boomer Line  
St. Clements, Ontario  
Canada N0B 2M0  
Phone: 1-877-695-9283  
Fax: 519-699-4146  
[www.embmfg.com](http://www.embmfg.com)