

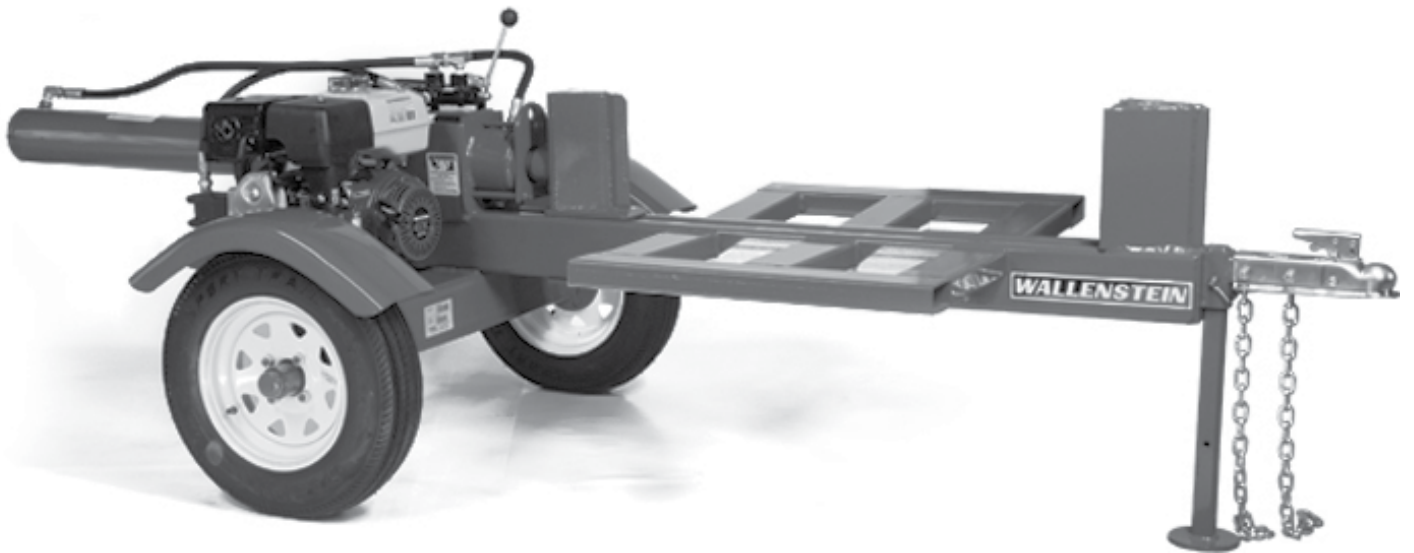

EMB Manufacturing Inc.  
4144 Boomer Line · St. Clements, On · N0B 2M0 · Canada  
Ph: (519) 699-9283 · Fax: (519) 699-4146  
[www.embmfg.com](http://www.embmfg.com)

# WX920 Trailer Log Splitter Parts Manual

S/N 2E9US1110ES330025 & After  
330025 & After



Refer to the operators  
manual for safe opera-  
tion and maintainance

2056T100 WX920 Parts Manual  
Rev F 041214

## Foreword

EMB Mfg. has prepared this parts manual to assist customers in ordering quality OEM replacement parts.

Proper and regular service and replacing old, worn or broken parts with the correct Wallenstein parts are essential to prolonging the life of your Wallenstein product. Please refer to this manual before ordering any replacement parts.

All information contained in this parts manual is based on the latest product specification available at the time of printing this manual. If your product differs from the specifications contained within this manual contact EMB Mfg. for information.

EMB reserves the right to alter specifications on their products at any time.

Reproduction of this parts manual of any kind is prohibited without prior written permission from EMB Mfg.

**Note:** Products with factory installed light kits will have a VIN number included. The last six numbers of this VIN number are the splitters serial number

Example: 2E9US1112BSXXXXXX

## Table of Contents

|                          |    |
|--------------------------|----|
| Bolt Torque              | 4  |
| Hydraulic Fitting Torque | 5  |
| Cylinder                 | 6  |
| Main Parts               | 7  |
| Engine & Pump            | 8  |
| Valve                    | 9  |
| Hub                      | 11 |
| Valve & Fittings         | 11 |
| 4-Way Wedge (Optional)   | 12 |
| Light Kit (Optional)     | 13 |
| Decal Breakdown          | 14 |

**CHECKING BOLT TORQUE**

The tables shown below give correct torque values for various bolts and capscrews. Tighten all bolts to the torques specified in chart unless otherwise noted. Check tightness of bolts periodically, using bolt torque chart as a guide. Replace hardware with the same strength bolt.

Torque figures indicated above are valid for non-greased or non-oiled threads and heads unless otherwise specified. Therefore, do not grease or oil bolts or capscrews unless otherwise specified in this manual. When using locking elements, increase torque values by 5%.

\* Torque value for bolts and capscrews are identified by their head markings.

**ENGLISH TORQUE SPECIFICATIONS**

| Bolt Diameter "A" | Bolt Torque*           |     |                        |     |                        |     |
|-------------------|------------------------|-----|------------------------|-----|------------------------|-----|
|                   | SAE 2<br>(N.m) (lb-ft) |     | SAE 5<br>(N.m) (lb-ft) |     | SAE 8<br>(N.m) (lb-ft) |     |
| 1/4"              | 8                      | 6   | 12                     | 9   | 17                     | 12  |
| 5/16"             | 13                     | 10  | 25                     | 19  | 36                     | 27  |
| 3/8"              | 27                     | 20  | 45                     | 33  | 63                     | 45  |
| 7/16"             | 41                     | 30  | 72                     | 53  | 100                    | 75  |
| 1/2"              | 61                     | 45  | 110                    | 80  | 155                    | 115 |
| 9/16"             | 95                     | 60  | 155                    | 115 | 220                    | 165 |
| 5/8"              | 128                    | 95  | 215                    | 160 | 305                    | 220 |
| 3/4"              | 225                    | 165 | 390                    | 290 | 540                    | 400 |
| 7/8"              | 230                    | 170 | 570                    | 420 | 880                    | 650 |
| 1"                | 345                    | 225 | 850                    | 630 | 1320                   | 970 |

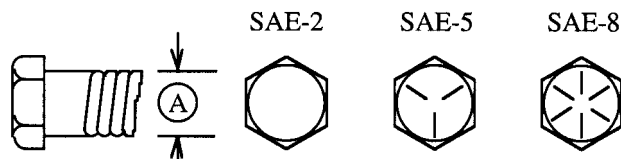
**METRIC TORQUE SPECIFICATIONS**

| Bolt Diameter "A" | Bolt Torque*         |      |                       |      |
|-------------------|----------------------|------|-----------------------|------|
|                   | 8.8<br>(N.m) (lb-ft) |      | 10.9<br>(N.m) (lb-ft) |      |
| M3                | .5                   | .4   | 1.8                   | 1.3  |
| M4                | 3                    | 2.2  | 4.5                   | 3.3  |
| M5                | 6                    | 4    | 9                     | 7    |
| M6                | 10                   | 7    | 15                    | 11   |
| M8                | 25                   | 18   | 35                    | 26   |
| M10               | 50                   | 37   | 70                    | 52   |
| M12               | 90                   | 66   | 125                   | 92   |
| M14               | 140                  | 103  | 200                   | 148  |
| M16               | 225                  | 166  | 310                   | 229  |
| M20               | 435                  | 321  | 610                   | 450  |
| M24               | 750                  | 553  | 1050                  | 774  |
| M30               | 1495                 | 1103 | 2100                  | 1550 |
| M36               | 2600                 | 1917 | 3675                  | 2710 |

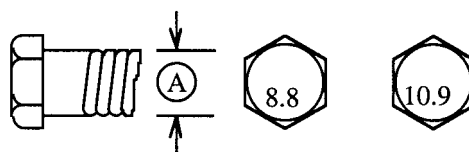

**Tightening Flare Type Tube Fittings \***

1. Check flare and flare seat for defects that might cause leakage.
2. Align tube with fitting before tightening.
3. Lubricate connection and hand tighten swivel nut until snug.
4. To prevent twisting the tube(s), use two wrenches. Place one wrench on the connector body and with the second tighten the swivel nut to the torque shown.

| Tube Size OD | Nut Size Across Flats | Torque Value* |           | Recommended Turns To Tighten (After Finger Tightening) |            |
|--------------|-----------------------|---------------|-----------|--|------------|
|              |                       | (N.m)         | (lb-ft)   | (Flats)  | (Turn)     |
| 3/16         | 7/16                  | 8             | 6         | 1  | 1/6        |
| 1/4          | 9/16                  | 12            | 9         | 1  | 1/6        |
| 5/16         | 5/8                   | 16            | 12        | 1  | 1/6        |
| <b>3/8</b>   | <b>11/16</b>          | <b>24</b>     | <b>18</b> | <b>1</b>   | <b>1/6</b> |
| 1/2          | 7/8                   | 46            | 34        | 1  | 1/6        |
| 5/8          | 1                     | 62            | 46        | 1  | 1/6        |
| 3/4          | 1-1/4                 | 102           | 75        | 3/4  | 1/8        |
| 7/8          | 1-3/8                 | 122           | 90        | 3/4  | 1/8        |

The torque values shown are based on lubricated connections as in reassembly.

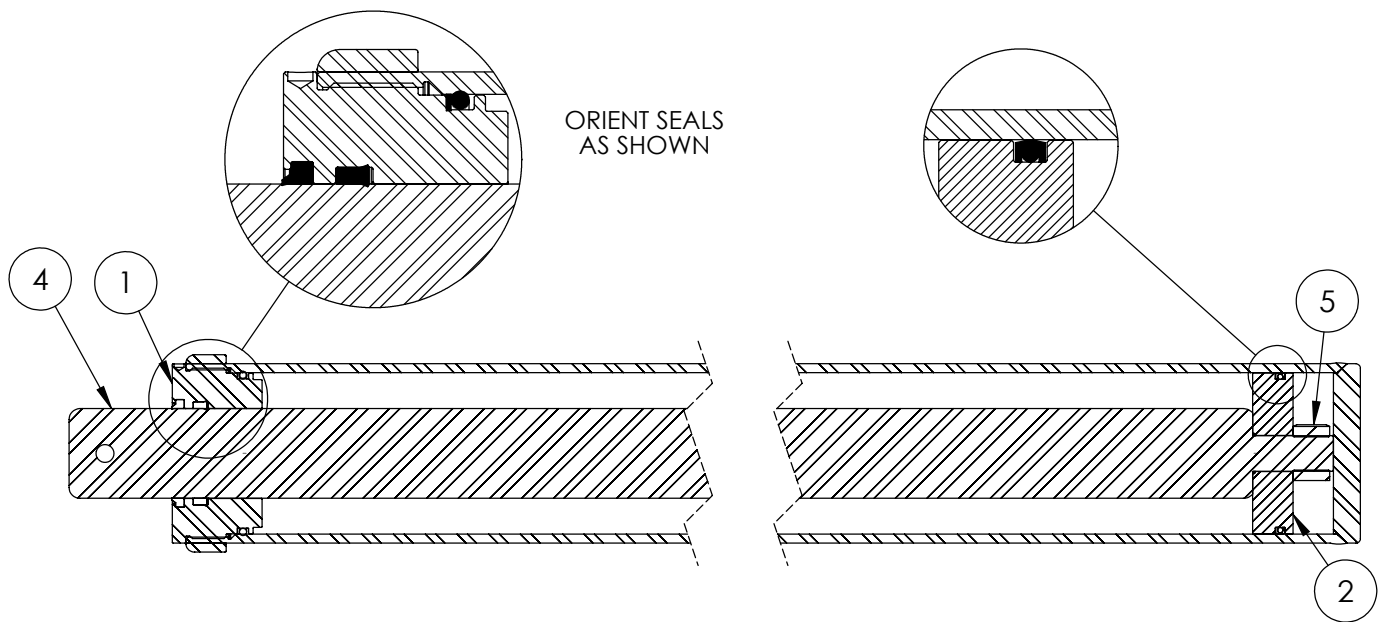

### 4-1/2" x 36" STROKE CYLINDER PARTS

| ITEM | PART NO.   | DESCRIPTION                               | QTY |
|------|------------|---|-----|
| 1    | G450-250SA | 4-1/2" Bore x 2-1/2" Rod Gland With Seals | 1   |
| 2    | P100-450SA | 4-1/2" Bore Piston With Seals             | 1   |
| 3    | 2032C2011  | Barrel, 4-1/2"                            | 1   |
| 4    | 2032C2013  | Rod, 2-1/2x 1                             | 1   |
| 5    | Z72292G8   | Hex Lock Nut 1NF Grade 8                  | 1   |
| 6    | SLK-4525   | Seal Kit, 4-1/2 x 2-1/2                   | 1   |

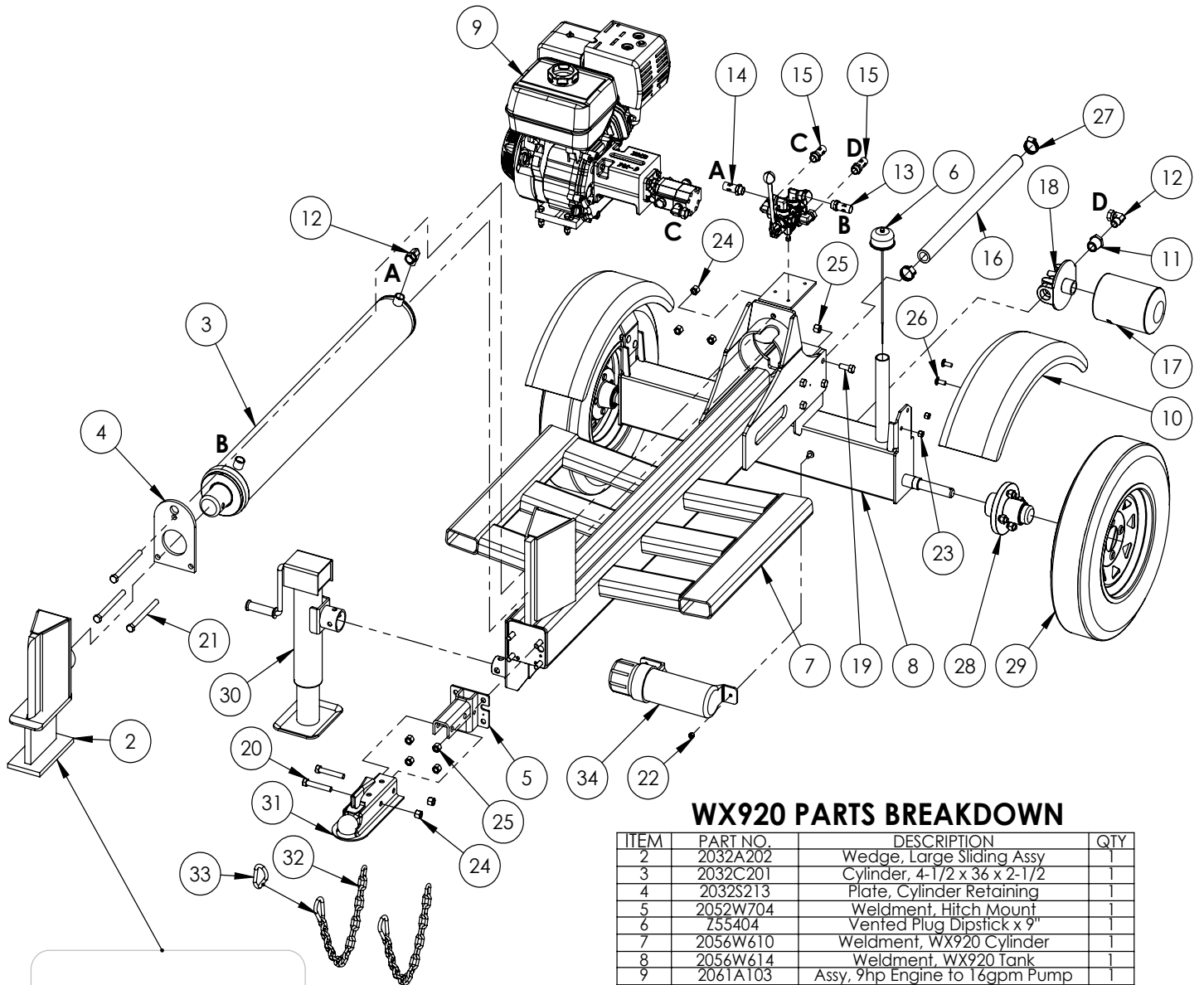

**WX920 PARTS BREAKDOWN**

| ITEM | PART NO. | DESCRIPTION                     | QTY |
|------|----------|---------------------------------|-----|
| 2    | 2032A202 | Wedge, Large Sliding Assy       | 1   |
| 3    | 2032C201 | Cylinder, 4-1/2 x 36 x 2-1/2    | 1   |
| 4    | 2032S213 | Plate, Cylinder Retaining       | 1   |
| 5    | 2052W704 | Weldment, Hitch Mount           | 1   |
| 6    | Z55404   | Vented Plug Dipstick x 9"       | 1   |
| 7    | 2056W610 | Weldment, WX920 Cylinder        | 1   |
| 8    | 2056W614 | Weldment, WX920 Tank            | 1   |
| 9    | 2061A103 | Assy, 9hp Engine to 16gpm Pump  | 1   |
| 10   | 2061W103 | Weldment, Fender                | 2   |
| 11   | Z51223   | Reducer, MP x FP 1608           | 1   |
| 12   | Z51331   | Elbow 90 MP x FPX 0808          | 2   |
| 13   | Z52301   | 1/2 Hose MP08 x MP08 x 16"      | 1   |
| 14   | Z52303   | 1/2 Hose, 1/2MP x 1/2MP x 36"   | 1   |
| 15   | Z52305   | 1/2 Hose, MP08 x MP08 x 24"     | 2   |
| 16   | Z52405   | Suction Hose, 1" x 22"          | 1   |
| 17   | Z55303   | Oil Filter - 1" - Particulate   | 1   |
| 18   | Z55304   | Filter Cap, FPT6 x FPT6         | 1   |
| 19   | Z71512   | Hex Bolt 1/2NC x 1-1/4          | 8   |
| 20   | Z71530   | Hex Bolt 1/2NC x 3              | 2   |
| 21   | Z71560   | Hex Bolt 1/2NC x 6              | 3   |
| 22   | Z72221   | Hex Lock Nut 5/16NC             | 1   |
| 23   | Z72231   | Hex Lock Nut 3/8NC              | 4   |
| 24   | Z72251   | Hex Lock Nut 1/2NC              | 5   |
| 25   | Z72251   | Hex Lock Nut 1/2NC              | 12  |
| 26   | Z76231   | Carriage Bolt 3/8NC x 1         | 4   |
| 27   | Z79401   | Hose Clamp, #16                 | 2   |
| 28   | Z91202   | Assembly, 1000# 4-Bolt Hub      | 2   |
| 29   | Z91302   | 5.30-12 LRB SportTrail 4 Spoked | 2   |
| 30   | Z91512   | Side-Wind 10" Swivel Jack       | 1   |
| 31   | Z91614   | 2" Hitch Coupler                | 1   |
| 32   | Z92303   | Safety Chain 1/4 x 2'           | 2   |
| 33   | Z92303-2 | Safety Snap                     | 2   |
| 34   | Z96503   | Manual Tube 3-1/2 Short         | 1   |
| ITEM | PART NO. | DESCRIPTION                     | QTY |
| 40   | 2014S414 | Plate, Sliding Wedge Capture    | -   |
| 41   | 2058W803 | Wedge, Large Sliding            | -   |
| 42   | Z71540   | Hex Bolt 1/2NC x 4              | -   |
| 43   | Z71576   | Hex Bolt 1/2NF x 1-1/2          | -   |
| 44   | Z72251   | Hex Lock Nut 1/2NC              | -   |

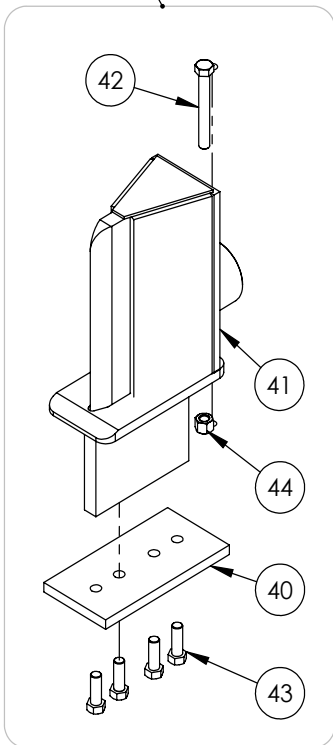

**2061A103 9hp ENGINE / PUMP ASSEMBLY PARTS**

| ITEM | PART NO. | DESCRIPTION              | QTY |
|------|----------|--------------------------|-----|
| 1    | Z47136   | Honda 9hp Engine         | 1   |
| 2    | Z53802   | Pump Mounting, PM-9      | 1   |
| 3    | Z46404   | Shaft Coupler L095 x 1   | 1   |
| 4    | Z46405   | Coupler Spider L095      | 1   |
| 5    | Z46409   | Shaft Coupler L095 x 1/2 | 1   |
| 6    | Z53205   | Pump, 16gpm Two-Stage    | 1   |
| 7    | Z51331   | Elbow 90 MP x FPX 0808   | 1   |
| 8    | Z71210   | Hex Bolt 5/16NC x 1      | 4   |
| 9    | Z46533   | Key 1/4 x 1/4 x 1        | 1   |
| 10   | Z46592   | Woodruff Key, 1/8 x 1/2  | 1   |
| 11   | Z71274   | Hex Bolt, 5/16NF x 1     | 4   |
| 12   | Z71320   | Hex Bolt 3/8NC x 2       | 4   |
| 13   | Z72231   | Hex Lock Nut 3/8NC       | 4   |

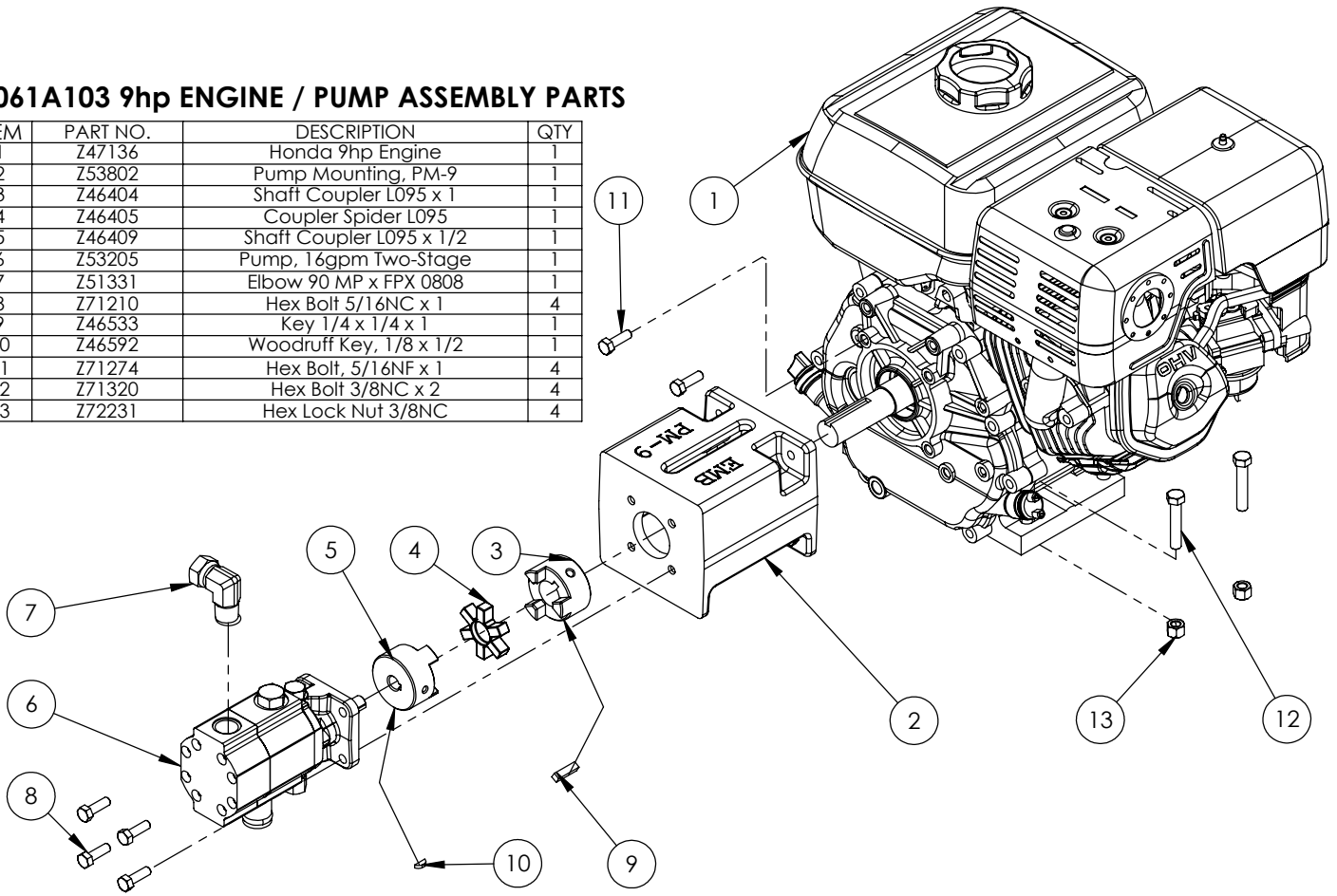



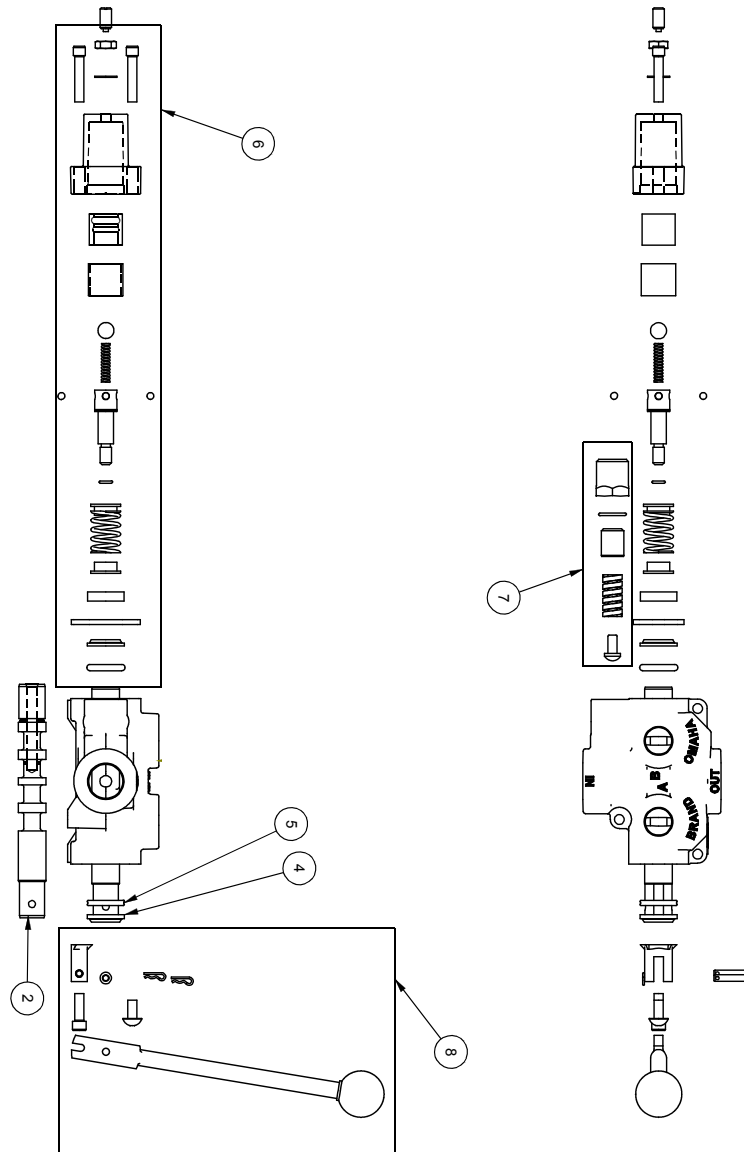

| ITEM NO. | QTY. | PART NO. | DESCRIPTION        |
|----------|------|----------|--------------------|
| 1        | 1    | AOCASTB  | AO CASTING         |
| 2        | 1    | LS304TAJ | SPOOL              |
| 3        | 1    | P1740    | NAME TAG           |
| 4        | 1    | SF305    | WIPER              |
| 5        | 1    | SF304    | QUAD RING          |
| 6        | 1    | SUB-LS   | SUB-LS             |
|          | 1    | B5057    | 7/16 BALL          |
|          | 4    | DC7604   | 3/16 BALL          |
|          | 1    | SF306    | RETAINER           |
|          | 1    | SF477L   | SH LS ENDCAP       |
|          | 1    | XDC672   | LS SLEEVE          |
|          | 1    | SF483    | SPACER             |
|          | 2    | SF486    | ALLEN SCREW        |
|          | 2    | SF489    | CENTER STOP        |
|          | 1    | SF490    | CENTERING SPRING   |
|          | 1    | SF492    | HOUSING            |
|          | 1    | SF315    | SPACER             |
|          | 1    | LS305    | DETENT SPRING      |
|          | 1    | DC7583   | O-RING 3-902       |
|          | 1    | SF496    | O-RING BLUE METRIC |
|          | 1    | LS306    | LS WIPER           |
|          | 1    | SF502    | 5/16 LOCK WASHER   |
|          | 1    | SF503    | PLUNGER SPRING     |
|          | 1    | SF504    | 5/16 HEX JAM NUT   |
| 7        | 1    | SUB-R    | RELIEF             |
|          | 1    | P1603    | CAP NUT            |
|          | 1    | SF322    | O-RING 2-016       |
|          | 1    | SF364A   | ADJ. SCREW         |
|          | 1    | B505     | SPRING             |
|          | 1    | SF361A   | POPPET             |
| 8        | 1    | Z56915   | HANDLE KIT         |
|          | 1    | SF377    | RETAINER           |
|          | 1    | SF376    | SEAL RETAINER      |
|          | 1    | SF367A   | CLEVIS             |
|          | 1    | SF368    | HANDLE             |
|          | 2    | SF369    | PIN                |
|          | 2    | P1767    | PIN CLIP           |
|          | 1    | HR5      | MACH. SCREW        |
|          | 1    | SF311    | KNOB               |
|          | 1    | SF308    | CAP SCREW          |
|          | 1    | SF303TAJ | SPOOL              |
| 9        | 1    | P1654    | WARNING TAG        |

| ITEM NO. | QTY. | PART NO. | DESCRIPTION      |
|----------|------|----------|------------------|
| 1        | 1    | B5057    | 7/16 BALL        |
| 2        | 4    | DC7604   | 3/16 BALL        |
| 3        | 1    | SF306    | RETAINER         |
| 4        | 1    | SF477L   | SH LS ENDCAP     |
| 5        | 1    | SF480    | SD SLEEVE        |
| 6        | 1    | SF483    | SPACER           |
| 7        | 2    | SF486    | ALLEN SCREW      |
| 8        | 2    | SF489    | CENTER STOP      |
| 9        | 1    | SF490    | CENTERING SPRING |
| 10       | 1    | SF492    | HOUSING          |
| 11       | 1    | SF315    | SPACER           |
| 12       | 1    | LS305    | DETENT SPRING    |
| 13       | 1    | DC7583   | O-RING 3-902     |
| 14       | 1    | SF496    | METRIC O-RING    |
| 15       | 1    | LS306    | LS WIPER         |
| 16       | 1    | SF502    | 5/16 LOCK WASHER |
| 17       | 1    | SF503    | SPRING PLUNGER   |
| 18       | 1    | SF504    | 5/16 HEX JAM NUT |

Note: This diagram is for reference only. Parts not sold separately.

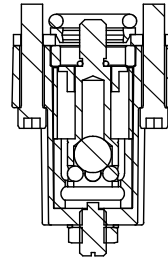
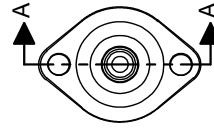
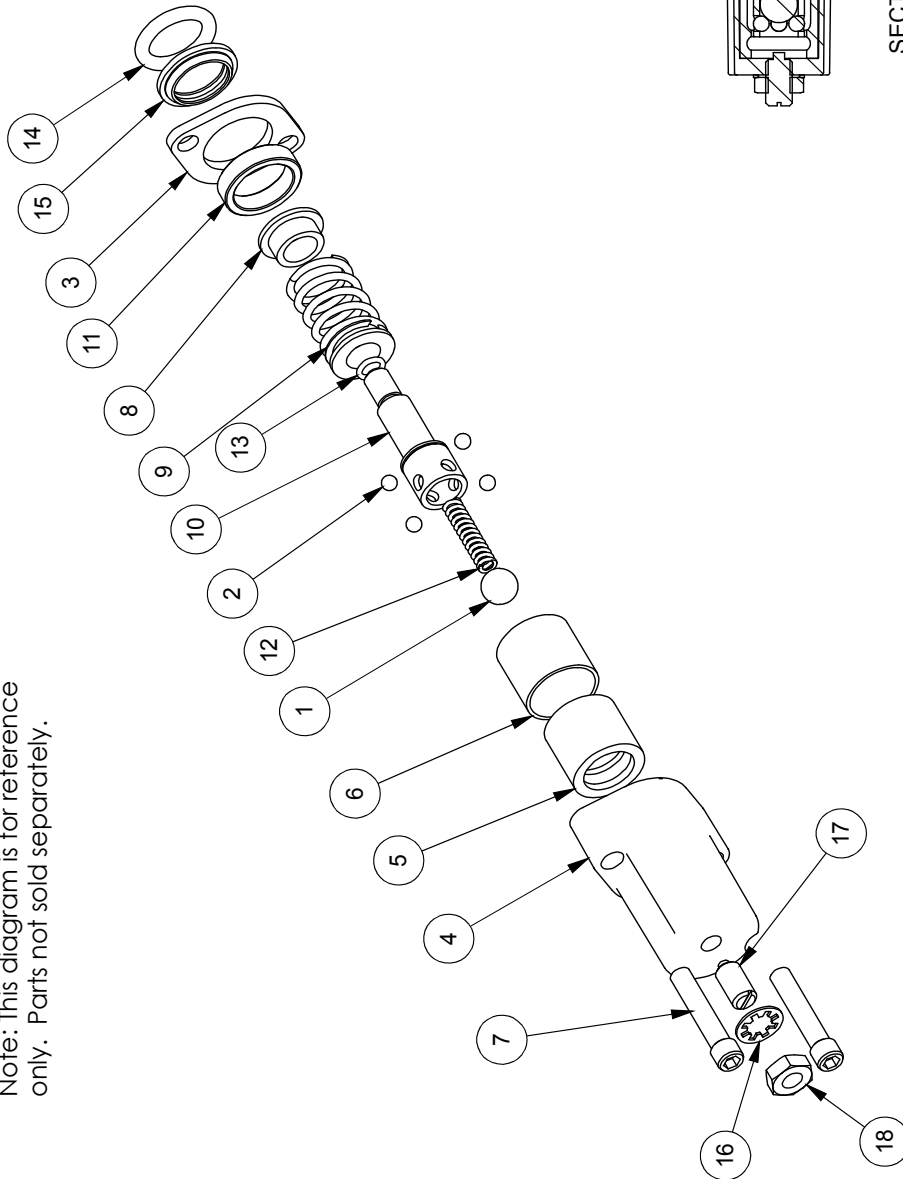

SECTION A-A

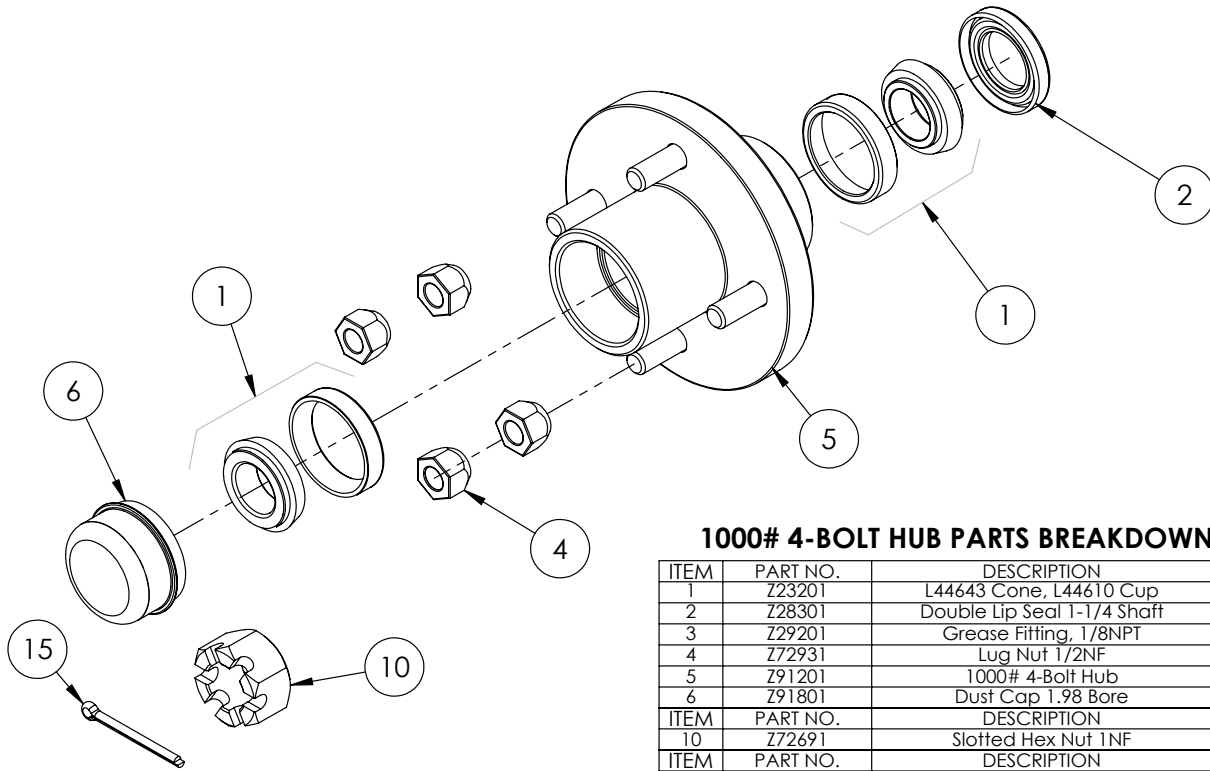

**1000# 4-BOLT HUB PARTS BREAKDOWN**

| ITEM | PART NO. | DESCRIPTION                 | QTY |
|------|----------|-----------------------------|-----|
| 1    | Z23201   | L44643 Cone, L44610 Cup     | 2   |
| 2    | Z28301   | Double Lip Seal 1-1/4 Shaff | 1   |
| 3    | Z29201   | Grease Fitting, 1/8NPT      | 1   |
| 4    | Z72931   | Lug Nut 1/2NF               | 4   |
| 5    | Z91201   | 1000# 4-Bolt Hub            | 1   |
| 6    | Z91801   | Dust Cap 1.98 Bore          | 1   |
| ITEM | PART NO. | DESCRIPTION                 | QTY |
| 10   | Z72691   | Slotted Hex Nut 1NF         | 1   |
| ITEM | PART NO. | DESCRIPTION                 | QTY |
| 15   | Z12322   | Cotter Pin 3/16 X 2         | 1   |

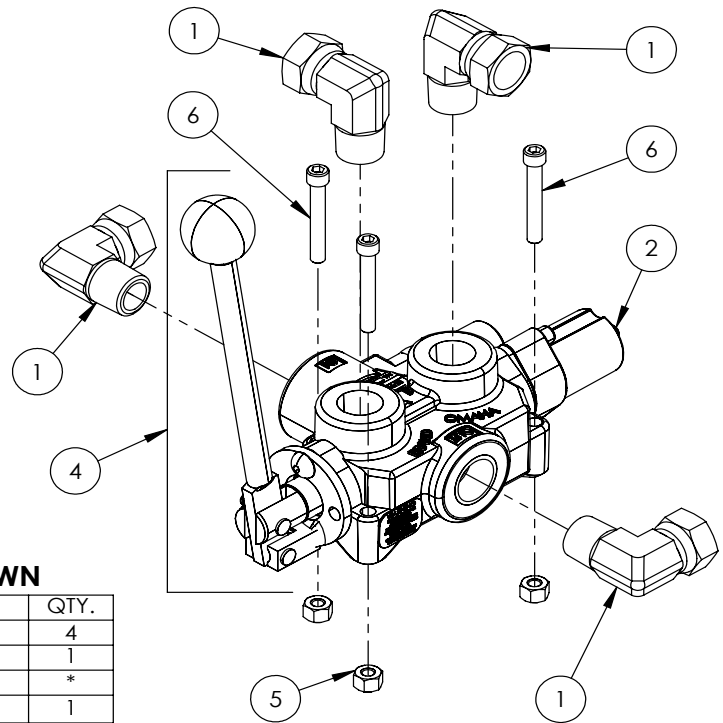

**VALVE AND FITTINGS PARTS BREAKDOWN**

| ITEM | PART NO. | Description                    | QTY. |
|------|----------|--------------------------------|------|
| 1    | Z51331   | Elbow 90 MP x FPX 0808         | 4    |
| 2    | Z56209   | Valve, Single Function Detent  | 1    |
| 3    | *Z56210* | Valve, Closed Center           | *    |
| 4    | Z56915   | Complete Handle Kit for Z56209 | 1    |
| 5    | Z72111   | Hex Lock Nut 1/4NC             | 3    |
| 6    | Z75114   | SHCS, 1/4NC x 1-3/4            | 3    |

\*CLOSED CENTER VALVE REQUIRED FOR "C" MODELS.\*

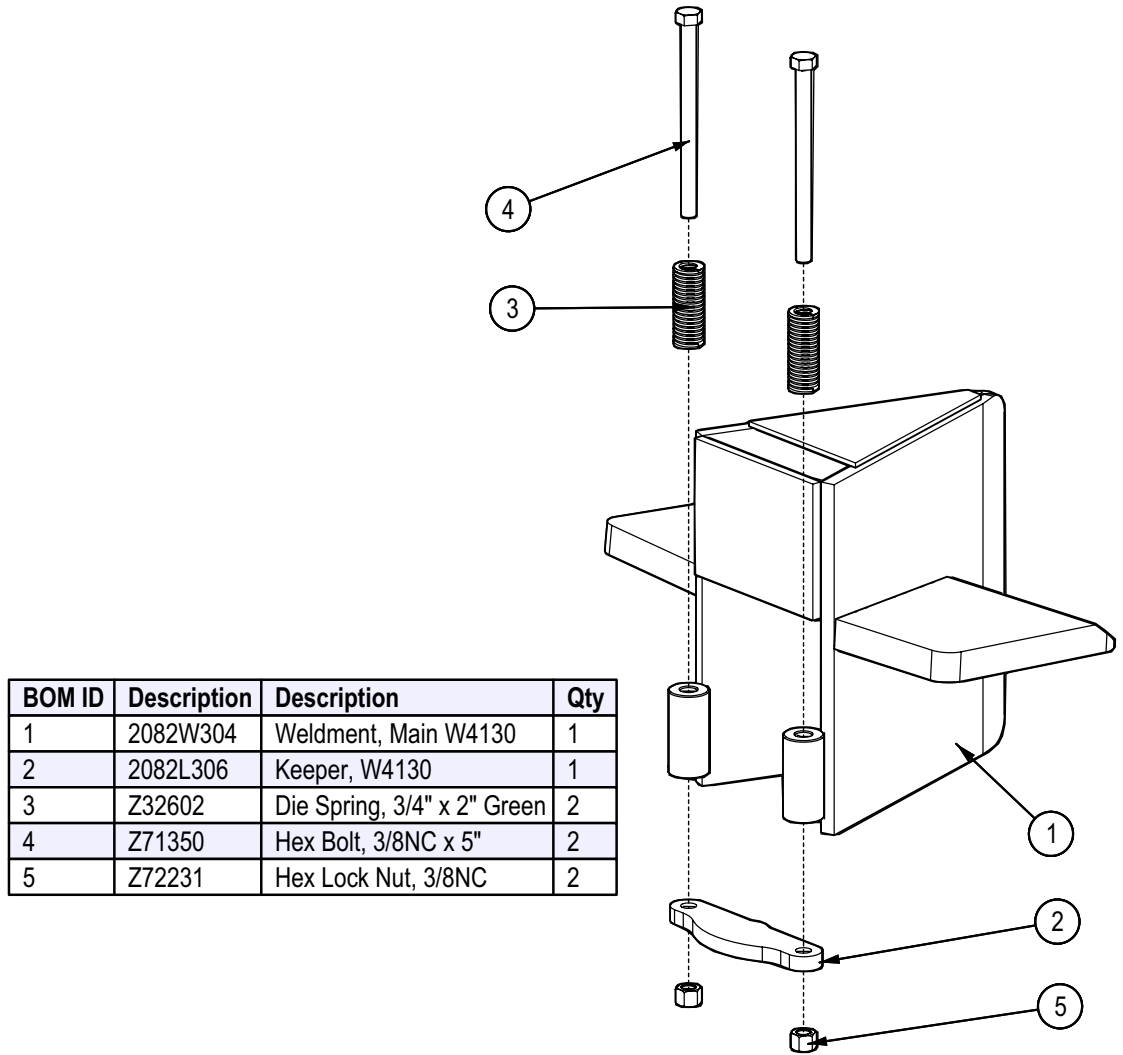

| BOM ID | Description | Description                 | Qty |
|--------|-------------|-----------------------------|-----|
| 1      | 2082W304    | Weldment, Main W4130        | 1   |
| 2      | 2082L306    | Keeper, W4130               | 1   |
| 3      | Z32602      | Die Spring, 3/4" x 2" Green | 2   |
| 4      | Z71350      | Hex Bolt, 3/8NC x 5"        | 2   |
| 5      | Z72231      | Hex Lock Nut, 3/8NC         | 2   |

# WX TRAILER SPLITTER WIRING

## RIGHT SIDE

**KEY**

- Bl - BLUE
- Br - BROWN
- Gr - GREEN
- Rd - RED
- Yl - YELLOW
- Bk - BLACK
- Wh - WHITE

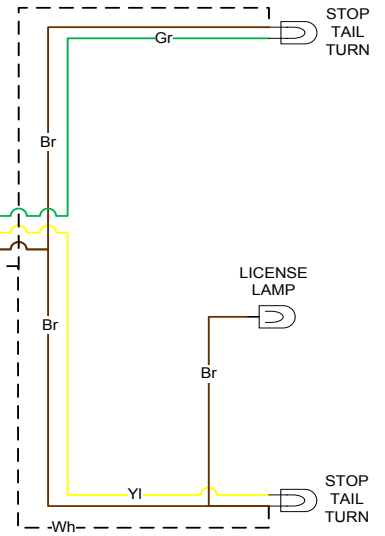
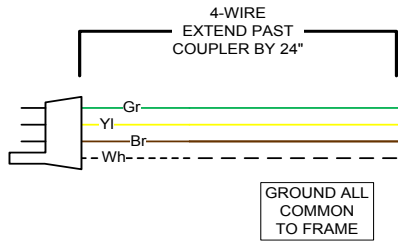

## LEFT SIDE

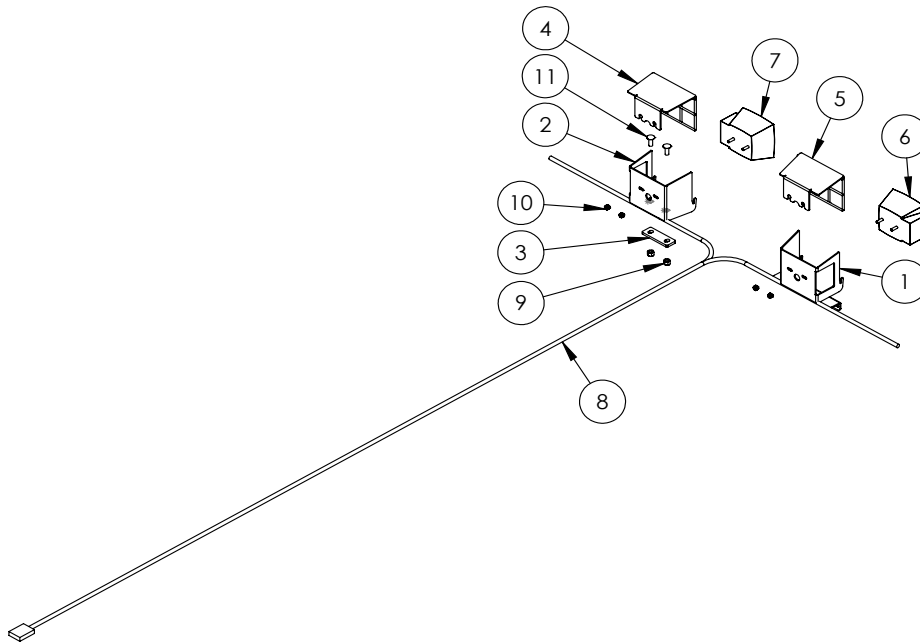

### 2089A350 LIGHT KIT (Optional)

| ITEM | PART NO. | DESCRIPTION                   | QTY |
|------|----------|-------------------------------|-----|
| 1    | 2054L402 | Light Bracket, LH             | 1   |
| 2    | 2054L601 | Light Bracket, RH             | 1   |
| 3    | 2054L622 | Bracket, Light Base           | 1   |
| 4    | 2054W403 | Light Guard, RH               | 1   |
| 5    | 2054W404 | Light Guard, LH               | 1   |
| 6    | Z61106   | Stop, Turn, Tail Light LH     | 1   |
| 7    | Z61107   | Stop, Turn, Tail Light RH     | 1   |
| 8    | Z62105   | 110" Wishbone Trailer Harness | 1   |
| 9    | Z72231   | Hex Lock Nut 3/8NC            | 2   |
| 10   | Z72941   | Serrated Washer Nut 1/4NC     | 4   |
| 11   | Z76231   | Carriage Bolt 3/8NC x 1       | 2   |

## TWO PANEL 920/930 SPLITTER DECAL BREAKDOWN

| ITEM | PART NO. | DESCRIPTION           | QTY |
|------|----------|-----------------------|-----|
| 1    | Z94119   | CAUTION - Read Manual | 1   |
| 2    | Z94123   | Keep Feet Clear       | 1   |
| 3    | Z94067   | Clear Guide           | 2   |
| 4    | Z94056   | Wallenstein           | 2   |
| 5    | Z94019   | Made in Canada        | 2   |
| 6    | Z94142   | 99 dB Sound Level     | 1   |
| 7    | Z94124   | Keep Hands Clear      | 1   |

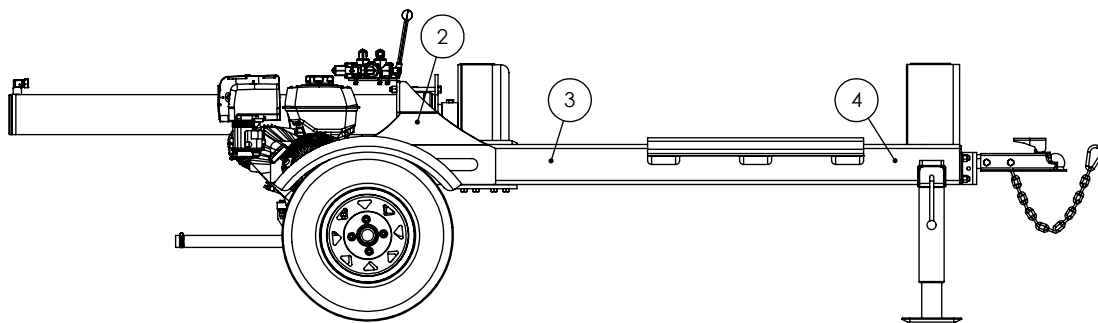
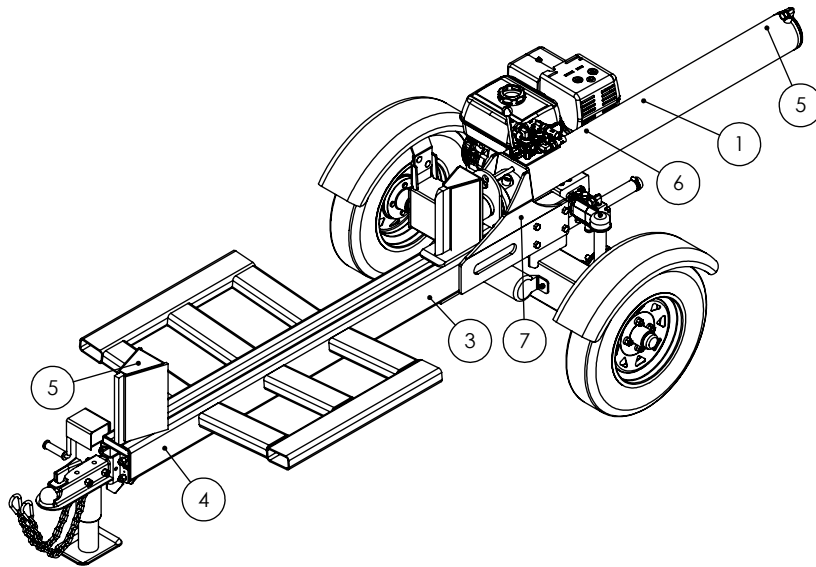

## Two Panel Trailer Splitter Decals

Z94019



Z94142



Z94067

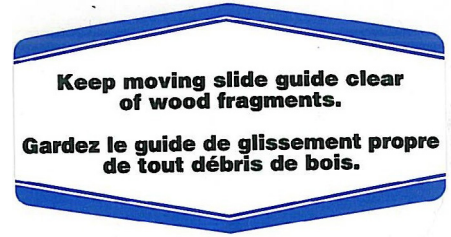

Z94056



Z94119



Z94123



Z94124





**WALLENSTEIN Products Manufactured by:**

**EMB MFG Inc.**

4144 Boomer Line  
St. Clements, Ontario  
Canada N0B 2M0  
Phone: 1-877-695-9283  
Fax: 519-699-4146  
[www.embmfg.com](http://www.embmfg.com)