



## **BX62R Chipper Parts Manual**

S/N 162R00359 & After



# Foreword

EMB Mfg. has prepared this parts manual to assist customers in ordering quality OEM replacement parts.

Proper and regular service and replacing old, worn or broken parts with the correct Wallenstein parts are essential to prolonging the life of your Wallenstein product. Please refer to this manual before ordering any replacement parts.

All information contained in this parts manual is based on the latest product specification available at the time of printing this manual. If your product differs from the specifications contained within this manual contact EMB Mfg. for information.

EMB reserves the right to alter specifications on their products at any time.

Reproduction of this parts manual of any kind is prohibited without prior written permission from EMB Mfg.

**Note:** Products with factory installed light kits will have a VIN number included. The last six numbers of this VIN number are the splitters serial number

Example: 2E9US1112BSXXXXXX

# Table of Contents

Main Parts	4
Discharge Chute	5
Roller Feed Chute	6
Z56209 Control Valve Seal Kit	8
Z56305 Flow Valve Seal Kit	8
C3540 Mounting Instructions and Breakdown	9
Binacchi PTO	11
Decals	13

### BX62R MAIN PARTS BREAKDOWN

ITEM	PART NO.	DESCRIPTION	QTY
1	1012A201	Assembly, Discharge Chute	1
2	1012L206	PTO Cover Mounting Bracket	1
3	1012L212	PTO Cover	1
4	1012M203	Knife, BX62 Rotor	4
5	1012M204	Knife, BX62 Ledger	1
6	1012W202	Housing, Upper Rotor	1
7	1012W204	Twig Breaker	1
8	1014 620R	6" Hydraulic Roller Feed Chute	1
9	1014W201	Housing, Bottom Rotor	1
10	1014W410	Rotor, BX62R	1
11	Z11431	Implement Pin 7/8x5-1/2	2
12	Z12110	Latch Pin 3/16	3
13	Z25203	4-Bolt Bearing 2" Bore	2
14	Z29202	Grease Zerk 1/4NF	2
15	Z34201	Gas Spring 7/8x11	2
16	Z44504	#5 Global PTO Shaft M10 Shear	1
17	Z71225	Hex Bolt 5/16NC x 2-1/2	2
18	Z71307	Hex Bolt 3/8NC x 3/4	2
19	Z71372G8	Hex Bolt, 3/8NF x 5/8 G8	3
20	Z71512	Hex Bolt 1/2NC x 1-1/4	7
21	Z71572G8	Hex Bolt 1/2NF x 7/8 Gr8	16
22	Z71672	Hex Bolt 5/8NF x 1-3/4	8
23	Z72221	Hex Lock Nut 5/16NC	2
24	Z72231	Hex Lock Nut 3/8NC	2
25	Z72251	Hex Lock Nut 1/2NC	6
26	Z72282	Hex Lock Nut 7/8NF	2
27	Z72531	Flange Nut 3/8NC	2
28	Z73131	Washer, 3/8	3
29	Z73380	Spring Washer 7/8	2
30	Z74132	Set Screw 3/8NF	4
31	Z94030	Decal, 1-3/4x13 WALLENSTEIN	1
32	Z96605	SMV Spade & Socket	1

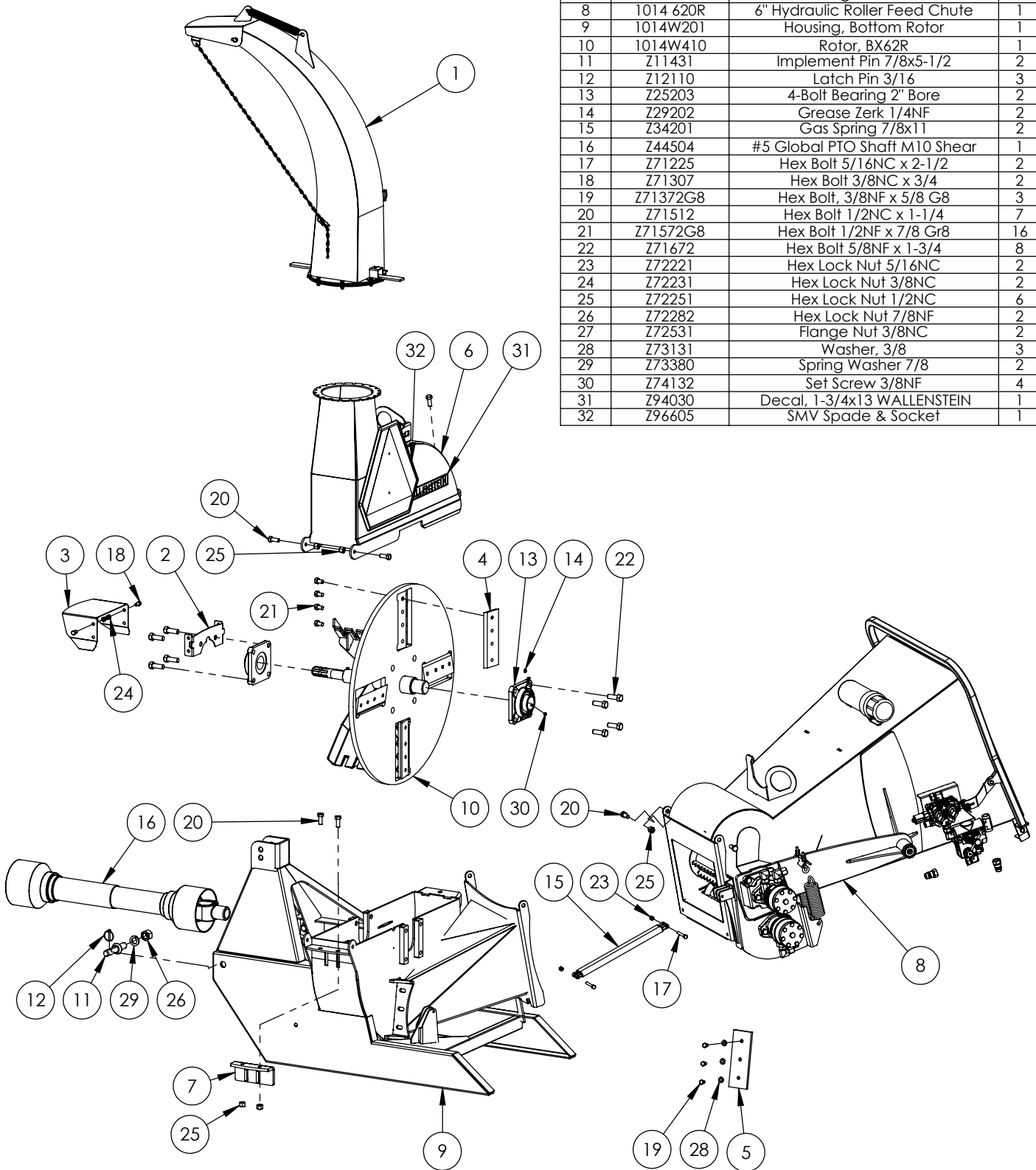

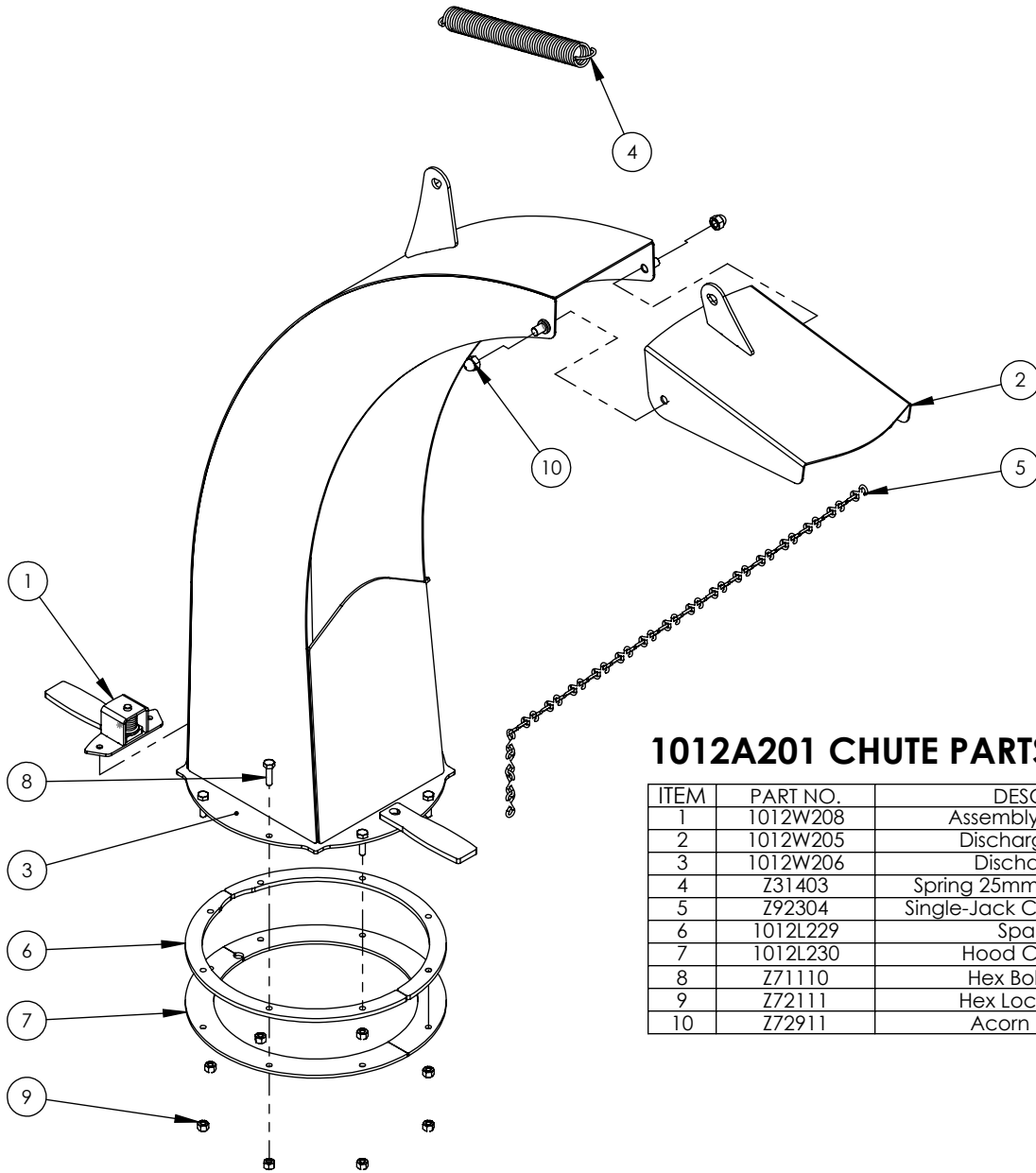

### 1012A201 CHUTE PARTS BREAKDOWN

ITEM	PART NO.	DESCRIPTION	QTY
1	1012W208	Assembly, Hood Latch	1
2	1012W205	Discharge Deflector	1
3	1012W206	Discharge Chute	1
4	Z31403	Spring 25mm x 178mm Heavy	1
5	Z92304	Single-Jack Chain # 10 [35 links]	3.2
6	1012L229	Spacer Ring	2
7	1012L230	Hood Capture Ring	2
8	Z71110	Hex Bolt 1/4NC x 1	8
9	Z72111	Hex Lock Nut 1/4NC	8
10	Z72911	Acorn Nut, 3/8NC	2

### BX62R ROLLER FEED PARTS BREAKDOWN

ITEM	PART NO.	DESCRIPTION	QTY
1	1011S103	Flap, Hopper	2
2	1012L251	Strap, Hopper Flap	1
3	1013M025	Arm Capture Bushing	1
4	1014L484	RollerPivot Link	1
5	1014W412	Hopper, Roller Feed	1
6	1014W402	Arm, Upper Roller	1
7	1014W403	Roller, Upper Feed	1
8	1014W404	Roller, Lower Feed	1
9	1014W405	Handle, Feed Regulating	1
10	Z11302	Clevis Pin 3/16 x 3/4	1
11	Z12301	Cotter Pin 3/32 X 3/4	1
12	Z24101	P208 Pillow Block 1 1/2	2
13	Z25204	4Bolt Bearing 1 1/2" Bore	2
14	Z29201	Grease Fitting, 1/8NPT	1
15	Z31501	Spring 2 x 7 Heavy	2
16	Z46593	Chipper Key	2
17	Z51122	Nipple, MP x MP 0808	1
18	Z51161	Tee, FP x FP x MP 080808	1
19	Z51331	Elbow 90 MP x FPX 0808	5
20	Z51383	Elbow 90 ORB x FPX 0808	4
21	Z51926	FP08 x Pioneer Coupler	2
22	Z52302	1/2 Hose, 1/2NPT x 1/2NPT x 12"	1
23	Z52303	1/2 Hose, 1/2MP x 1/2MP x 36"	3
24	Z52304	1/2 Hose, 1/2MP x 1/2MP x 120"	2
25	Z54102	M&S Hydraulic Motor	2
26	Z56209	Brand Control Valve	1
27	Z56305	Brand Hydraulic Flow Control	1
28	Z71107	Hex Bolt 1/4NC x 3/4	4
29	Z71112	Hex Bolt 1/4NC x 1 1/4	1
30	Z71122	Hex Bolt 1/4NC x 2 1/4	2
31	Z71217	Hex Bolt 5/16NC x 1 3/4	3
32	Z71515	Hex Bolt 1/2NC x 1 1/2	4
33	Z71525	Hex Bolt 1/2NC x 2 1/2	4
34	Z71617	Hex Bolt 5/8NC x 1 3/4	4
35	Z72111	Hex Lock Nut 1/4NC	3
36	Z72221	Hex Lock Nut 5/16NC	7
37	Z72251	Hex Lock Nut 1/2NC	8
38	Z72261	Hex Lock Nut 5/8NC	4
39	Z72911	Acorn Nut, 3/8NC	2
40	Z74110	Set Screw 1/4NC	2
41	Z76522	Eye Bolt 5/16NC x 2	2
42	Z76712	Selftapping Screw #10	3
43	Z96503	Manual Tube 31/2 Short	1
44	1014L411	Feed Handle Link Weldment	1

### BX62R ROLLER FEED PARTS BREAKDOWN

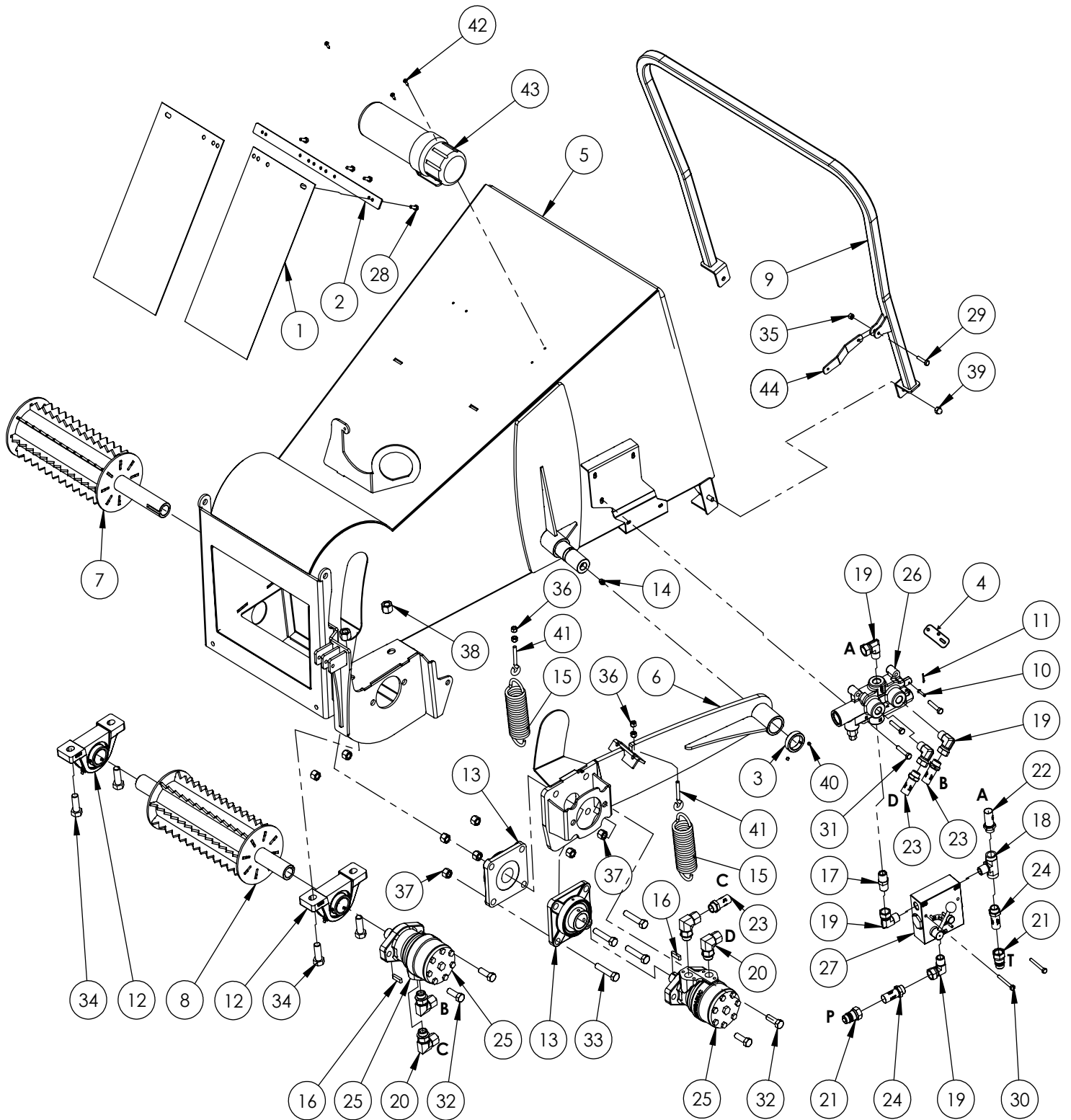

**THE MATCHING LETTER ANNOTATIONS  
ILLUSTRATE THE FITTINGS THAT ARE  
CONNECTED TOGETHER WITH A HOSE**

Z56209 Control Valve Seal Kit

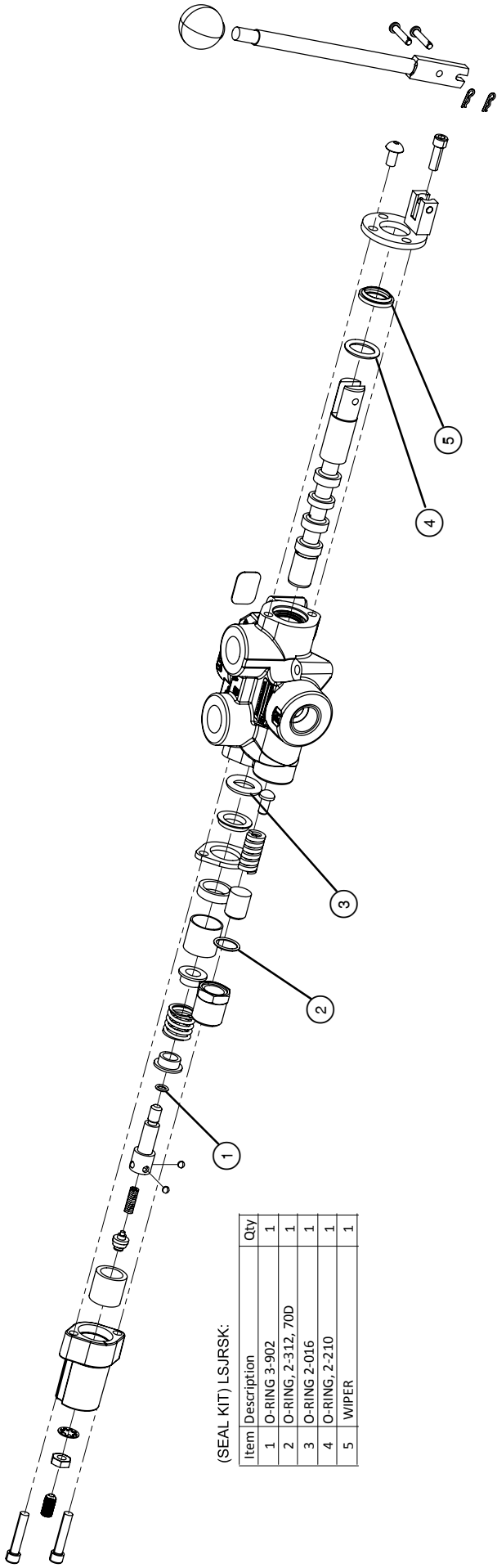

(SEAL KIT) LSJRSK:

Item	Description	Qty
1	O-RING 3-902	1
2	O-RING, 2-312, 70D	1
3	O-RING 2-016	1
4	O-RING, 2-210	1
5	WIPER	1

Item	Description	Qty
1	SEAL RETAINER	2
2	2 B5024 ORING, 2116	2
3	2 P1659 ORING, 2019	2
4	ORING, 3912	2
Legacy Items Incl. In Kit But Not Shown		
	P1737 ORING, 2021	2
	ORING, 2020	2

Z56305 Flow Valve Seal Kit

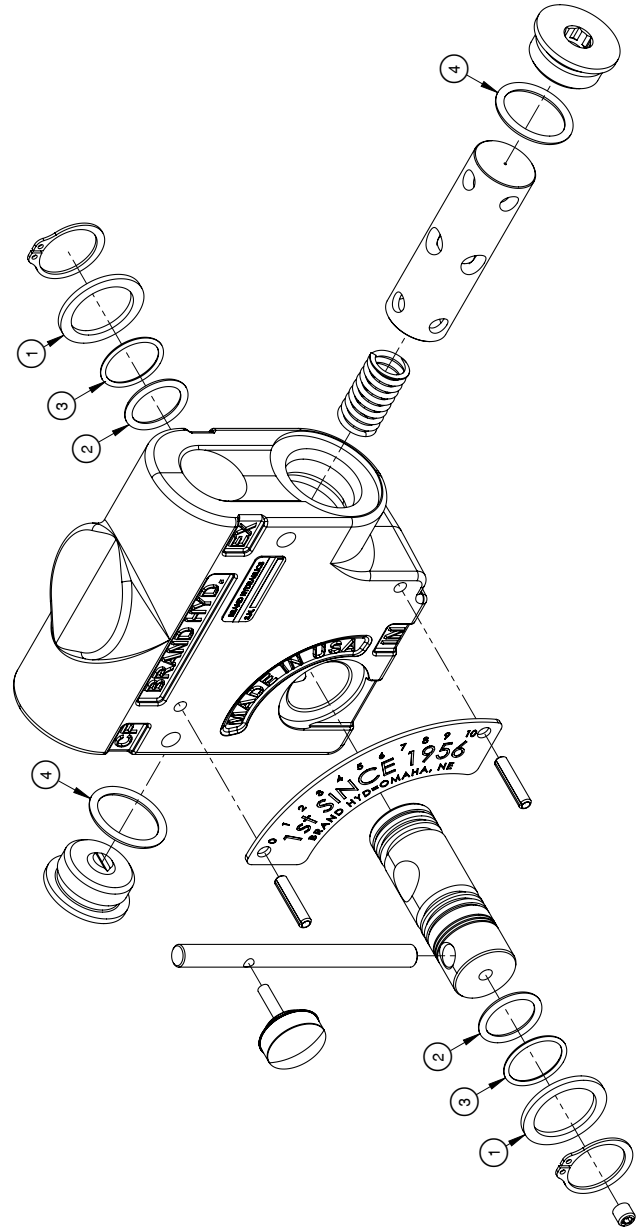



### C3540 Mounting Instructions (optional)

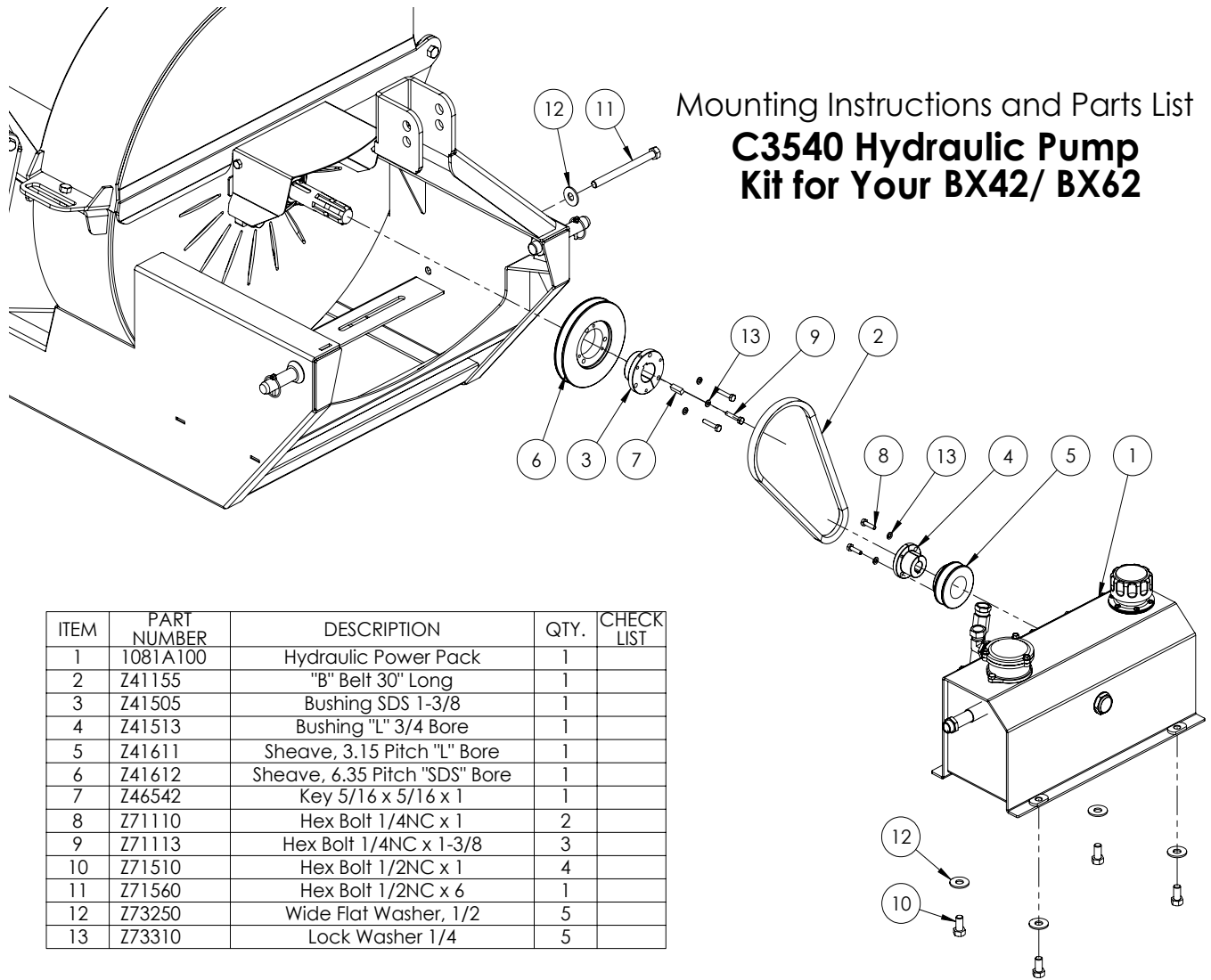

### Mounting Instructions and Parts List C3540 Hydraulic Pump Kit for Your BX42/ BX62

ITEM	PART NUMBER	DESCRIPTION	QTY.	CHECK LIST
1	1081A100	Hydraulic Power Pack	1	
2	Z41155	"B" Belt 30" Long	1	
3	Z41505	Bushing SDS 1-3/8	1	
4	Z41513	Bushing "L" 3/4 Bore	1	
5	Z41611	Sheave, 3.15 Pitch "L" Bore	1	
6	Z41612	Sheave, 6.35 Pitch "SDS" Bore	1	
7	Z46542	Key 5/16 x 5/16 x 1	1	
8	Z71110	Hex Bolt 1/4NC x 1	2	
9	Z71113	Hex Bolt 1/4NC x 1-3/8	3	
10	Z71510	Hex Bolt 1/2NC x 1	4	
11	Z71560	Hex Bolt 1/2NC x 6	1	
12	Z73250	Wide Flat Washer, 1/2	5	
13	Z73310	Lock Washer 1/4	5	

### C3540 Parts Breakdown (optional)

## 1081A100 Hydraulic Power Pack Parts List

ITEM	PART NUMBER	DESCRIPTION	QTY.
1	1081S101	Gasket, Tank	1
2	1081S102	Gasket, Pump	1
3	1081W101	Tank	1
4	Z51192	Socket Plug 1/2NPT	1
5	Z51221	Reducer, 3/4NPT x 1/2NPT	1
6	Z51331	1/2NPT x 1/2NPT Fem Swivel	1
7	Z51741	#12ORB x 3/4 NPT Adapter	1
8	Z51751	#10ORB x 1/2FNPT 90 Elbow	1
9	Z52301	1/2 Hose 1/2NPT x 1/2NPT x 16"	1
10	Z53101	Salami Pump - Outrigger Bearing	1
11	Z55201	Tank Mounted Return Filter	1
12	Z55401	Breather Filler Cap	1
13	Z55901	Site Glass 1NPT	1
14	Z71107	Hex Bolt 1/4NC x 3/4	2
15	Z71207	Hex Bolt 5/16NC x 3/4	12
16	Z51321	1/2FP x 1/2FPx	1
17	Z73121	Aluminum Washer, 5/16	12
18	Z73141	Aluminum Washer, 7/16	2
19	Z76711	Self-tapping Screw #10	6
20	Z51111	Pipe Nipple, 1/2NPT x 7"	1
21	Z71412	Hex Bolt 7/16NC x 1-1/4	2
22	Z72140	Hex Lock Nut 7/16NC	2

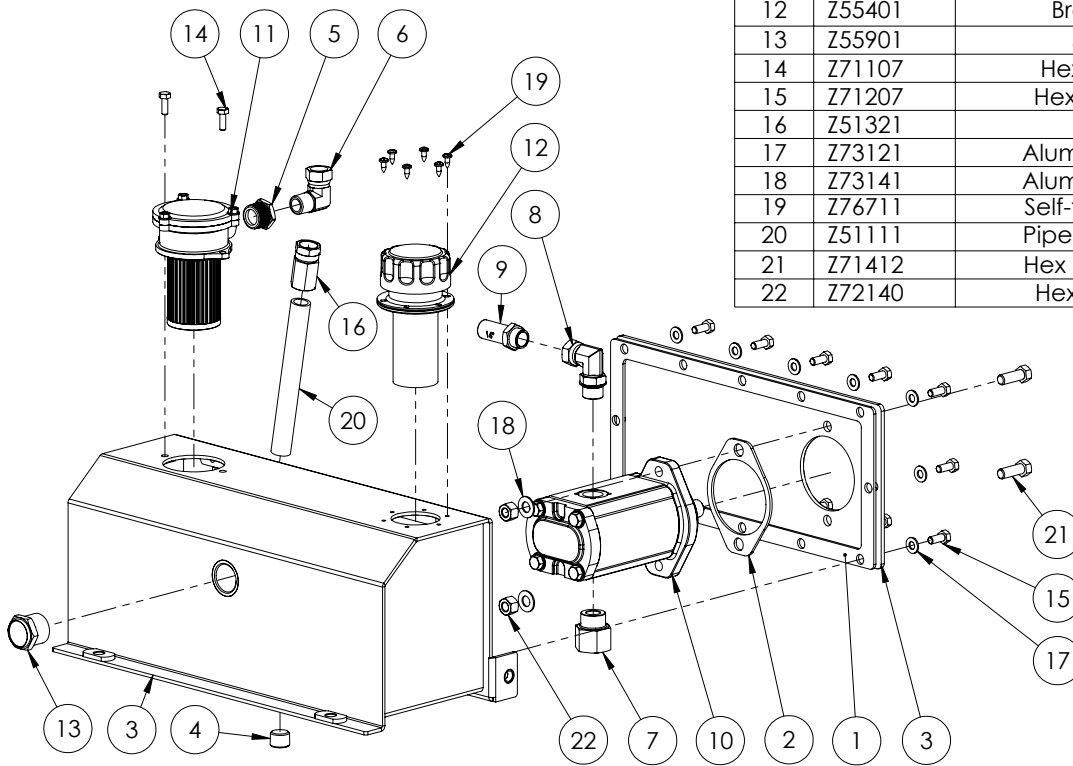

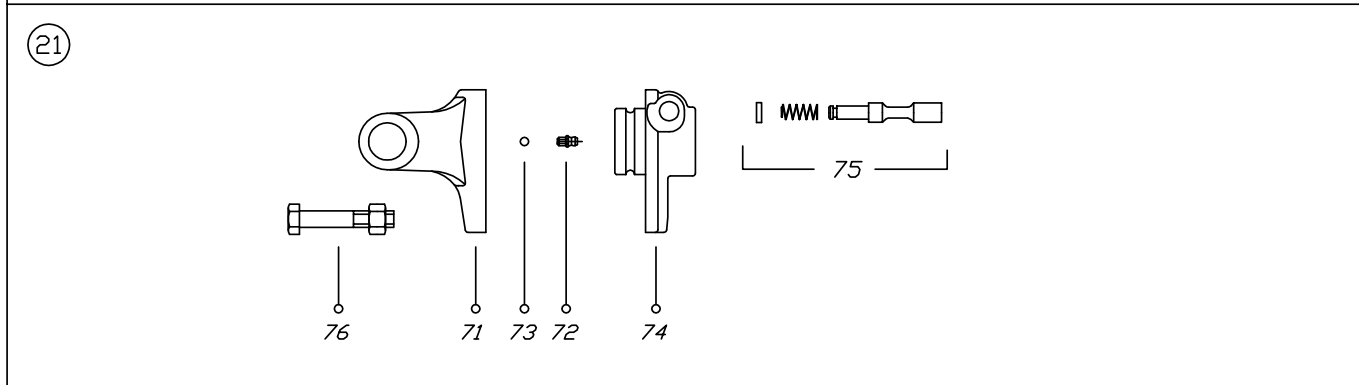
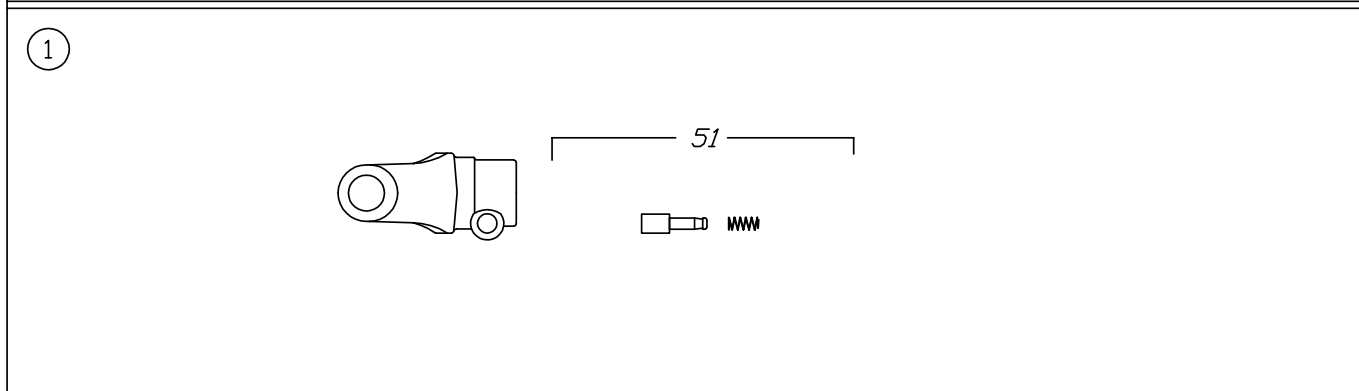
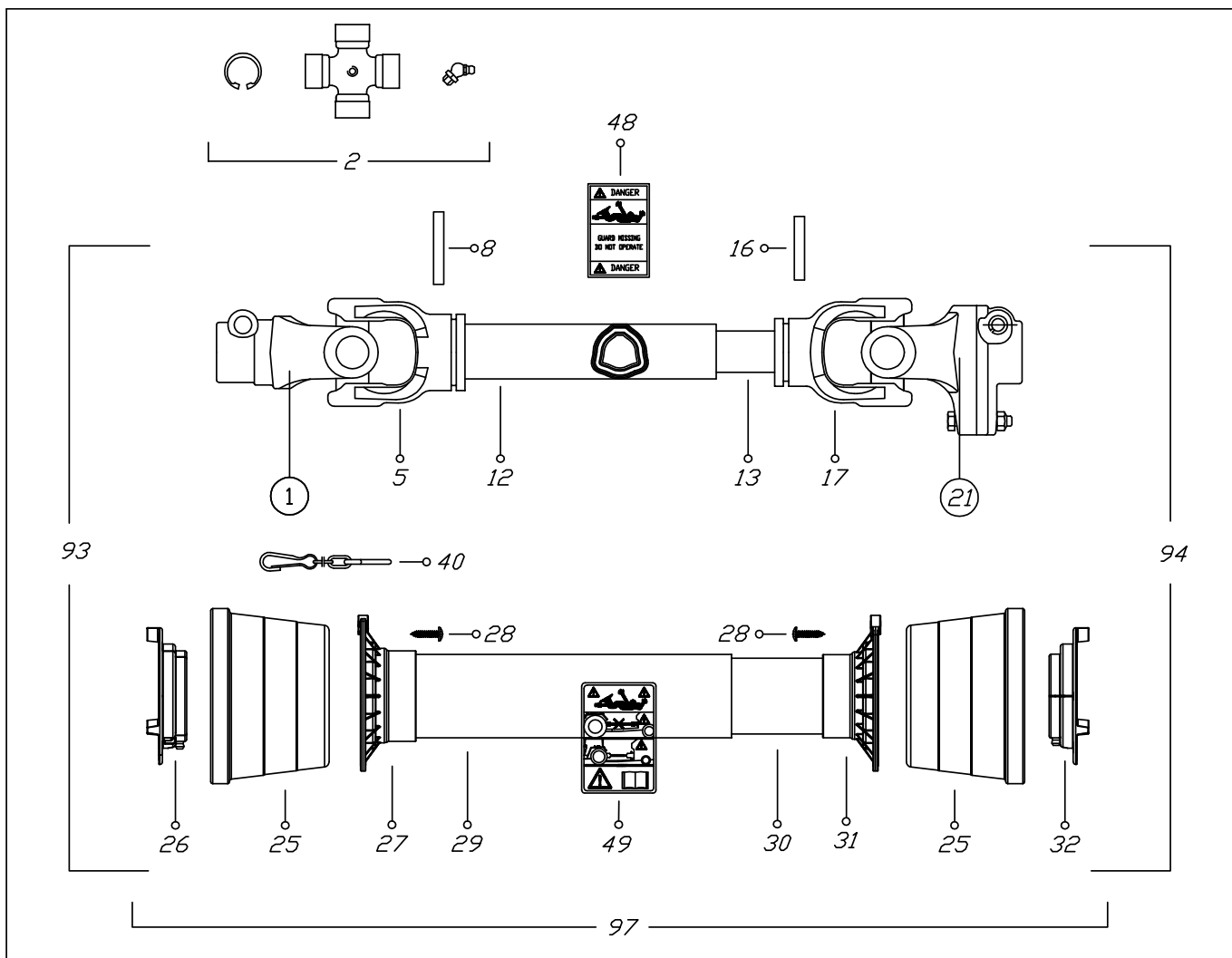

<p>VIETATE LE RIPRODUZIONI NON AUTORIZZATE NOT PERMITTED AL RIGHTS RESERVED</p>	<p>TOUTE REPRODUCTION NON AUTORISEE EST INTERDITE NICHT GENEHMIGTE VERVIELFAELTUNGEN SIND UNZULAESSIG</p>	<p>CODICE C.E.D. B4N061USA60098</p>	<p>DATA 25/03/10</p>
---	---	---	--------------------------

<b>Binacchi SPARE PARTS LIST : B5D056US098001</b>			
<b>POS.</b>	<b>DESCRIPTION</b>	<b>Q.</b>	<b>Part #</b>
01	YOKE	1	0800503
02	CROSS JOURNAL ASS.	2	08205
05	OUTER TUBE YOKE	1	08005021
08	FLEXIBLE PIN	1	098701075
12	CM. 100 CARDAN TUBE(*)	1	09881523100
13	CM. 100 CARDAN TUBE(*)	1	09881454100
16	FLEXIBLE PIN	1	0987001065
17	INNER TUBE YOKE	1	08005011
21	SHEAR BOLT	1	08805A604633
25	CONE SHIELD BELL 05-06	2	021906C001
26	OUTER BEARING 05	1	025505C001
27	OUTER BASE CONE 05-06	1	025406C001
28	SCREW	6	0998052242
29	OUTER SAFETY TUBE	1	0988981NB5056
30	INNER SAFETY TUBE	1	0988975NB5056
31	INNER BASE CONE 05-06	1	025406C002
32	INNER BEARING 05	1	025505C002
40	CHAIN	1	0252000001
48	LABEL DANGER OUTER DRIVE TUBE	1	09872006
49	EXTERNAL SHIELD LABEL	1	09872003
51	COMPLETE PUSH BUTTTON	1	0986014047
71	YOKE FOR LB5	1	08896905
72	GREASE NIPPLE	1	0984010150
73	STEEL BALL	23	098680104
74	HUB	1	088965A60
75	PUSH PIN SET	1	0986014075
76	NUT AND BOLT M10 x 1.5 x 55 10.9	1	Z19407 (5 Pack)
93	OUTER HALF SHAFT	1	B5056US2
94	INNER HALF SHAFT	1	B5056US1098001
97	SAFETY GUARD	1	083US05056

### BX62R DECAL BREAKDOWN

ITEM	PART NO.	DESCRIPTION	QTY
1	Z94056	WALLENSTEIN Decal	2
2	Z94019	1" Dia. Made In Canada	5
3	Z94173	BX62 Triangle Decal	2
4	Z94007	DANGER - Rotating Blades	3
5	Z94006	CAUTION - Read Manual	1
6	Z94009	DANGER - Rotating Driveline Hazard	1
7	Z94008	DANGER - Thrown Object Hazard	3
8	Z94602	Reflector	1
9	Z94015	Reverse, Neutral, Feed - RH	1
10	Z94014	Reverse, Neutral, Feed - LH	1
11	Z94005	High Pressure	2

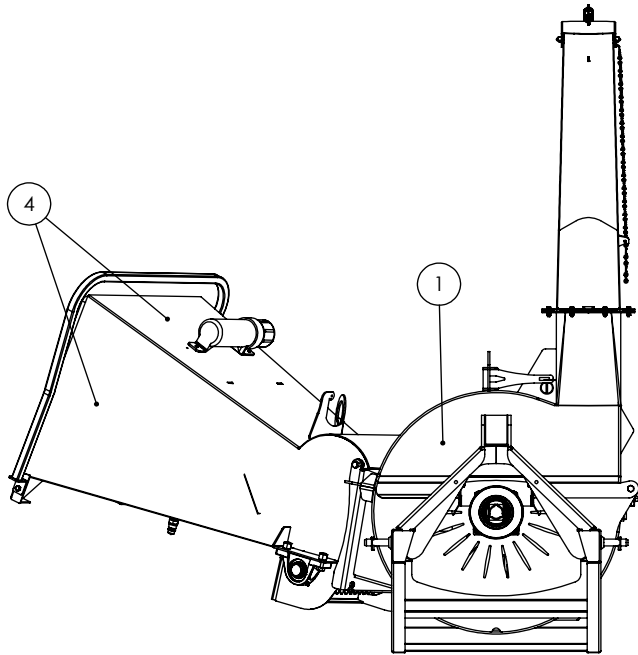

FRONT

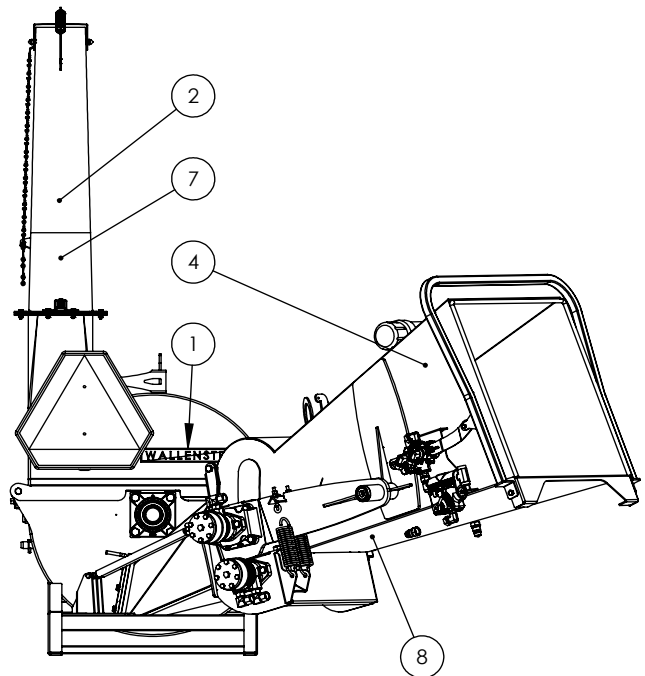

BACK

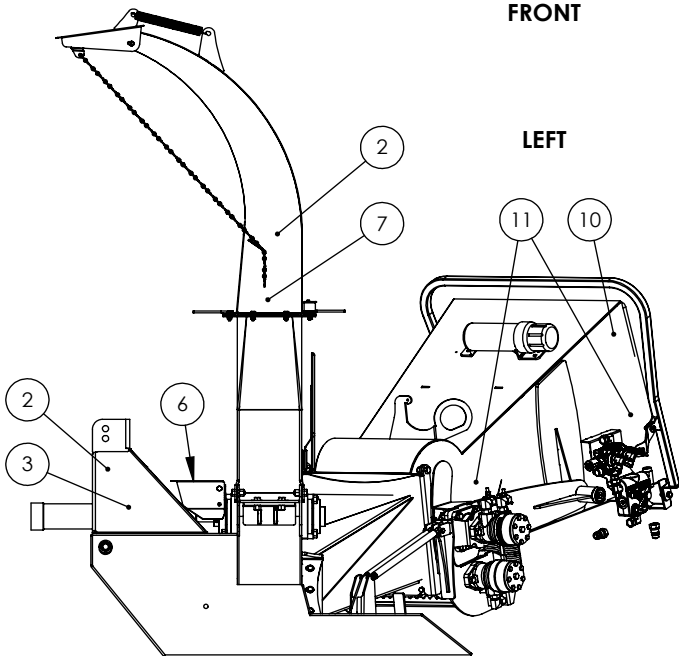

LEFT

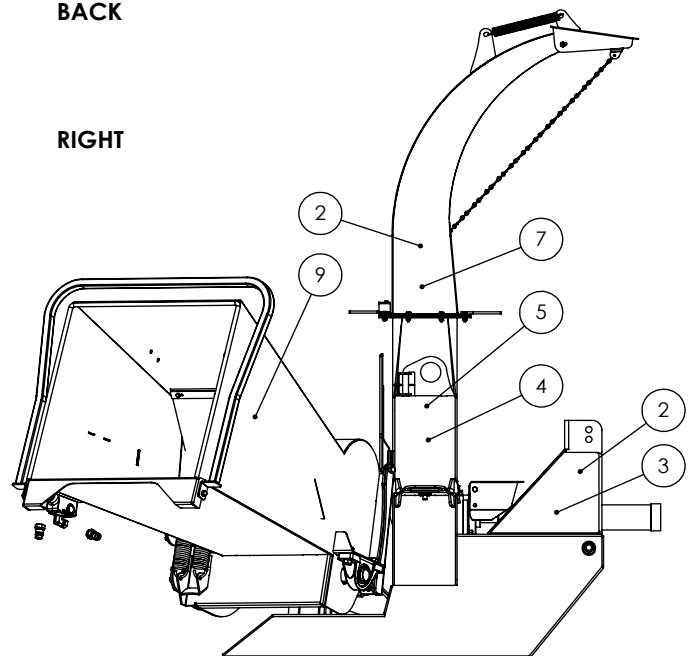

RIGHT

# Decals BX62R

Z94056



Z94173



Z94006

**⚠ CAUTION**

- Read and understand operator's manual before starting. Review safety instructions annually.
- Turn machine off, stop and disable engine, remove ignition key and place in your pocket, set park brake and wait for all moving parts to stop before adjusting, servicing, maintaining, repairing or unplugging.
- Keep the working area clean and free of debris to prevent slipping or tripping. Operate only on level ground.
- Close and secure rotor cover before operating.
- Close and secure all guards, deflectors and shields before starting and operating.
- Keep hydraulic lines and fittings tight, in good condition and free of leaks.
- Keep hands, feet, hair and clothing away from moving parts. Never wear loose clothing around machinery.
- Keep driveline universal joint angles equal and small as possible.
- Do not point discharge at people, animals or buildings. Rotor can expel wood chips fast enough to cause injury.
- Do not allow children, animals or unauthorized people into working area.
- Do not run machine inside a closed building to prevent asphyxiation from engine exhaust.
- Use care when feeding material into chipper. Do not send metal, bottles, cans, rocks, glass or other foreign material into wood chipper. If foreign material enters chipper, stop the machine, turn engine off and place ignition key in your pocket and wait for all moving parts to stop before removing material and/or unplugging. Inspect machine for damaged or loose parts before returning to work.
- Always wear P.P.E. (Personal Protective Equipment) such as safety goggles and heavy gloves whenever operating machine.
- Do not place hands or any body parts into feed hopper during operation.
- Do not move or transport chipper when the rotor is turning.
- Do not exceed a safe travel speed when transporting. Cross safety chain under hitch on trailer model when attaching to a truck.

Z94006

Z94007

**⚠ DANGER**

**ROTATING CUTTING BLADES**

Keep hands and feet out of inlet and discharge openings while machine is operating to avoid serious personal injury. Stop engine, remove spark plug wire and allow machine to come to a complete stop before clearing obstructions or making adjustments.

Z94007

Z94019



Z94009

**⚠ DANGER**

**ROTATING DRIVELINE HAZARD**

**KEEP AWAY**

To prevent serious injury or death from rotating driveline:

- Keep all guards in place when operating.
- Operate only at 540 RPM.
- Keep hands, feet, hair and clothing away from moving parts.
- Keep U-joint angles equal and small as possible.
- Do not exceed driveline manufacturers recommended operating length.

Z94009

Z94015

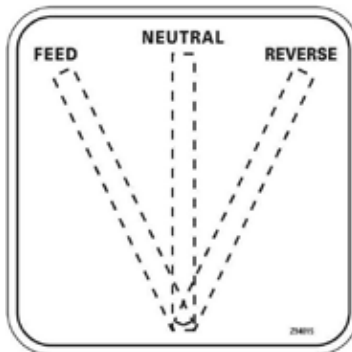

Z94014

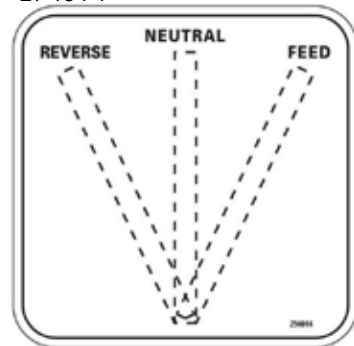

Z94008

**⚠ DANGER**

**THROWN OBJECT HAZARD**

To prevent serious injury or death from thrown objects:

- Turn machine off, stop and disable engine, remove ignition key and place in your pocket, set park brake and wait for all moving parts to stop before adjusting, servicing, maintaining repairing or unplugging.
- Do not direct discharge duct towards people, animals or property. Always wear appropriate safety gear. Keep hands and feet out of discharge openings.
- Keep others away.

Z94008

Z94602



Z94005

**⚠ WARNING**

**HIGH PRESSURE FLUID HAZARD**

To prevent serious injury or death from high-pressure fluid:

- Relieve pressure on system before repairing or adjusting.
- Wear proper hand and eye protection when searching for leaks. Use wood or cardboard instead of hands.
- Keep all components in good repair.

Z94005

## TWO PANEL BX62R DECAL BREAKDOWN

ITEM	PART NO.	DESCRIPTION	QTY
1	Z94056	WALLENSTEIN Decal	2
2	Z94019	1" Dia. Made In Canada	5
3	Z94173	BX62R Model	2
4	Z94120	DANGER - Rotating Blades	3
5	Z94119	CAUTION - Read Manual	1
6	Z94118	DANGER - Rotating Driveline Hazard	1
7	Z94117	DANGER - Thrown Object Hazard	3
8	Z94602	Reflector	1
9	Z94015	Reverse, Neutral, Feed - RH	1
10	Z94014	Reverse, Neutral, Feed - LH	1
11	Z94167	High Pressure	2
12	Z94143	Noise Level	1
13	Z94144	RH Rotation	1
14	Z94145	LH Rotation	1

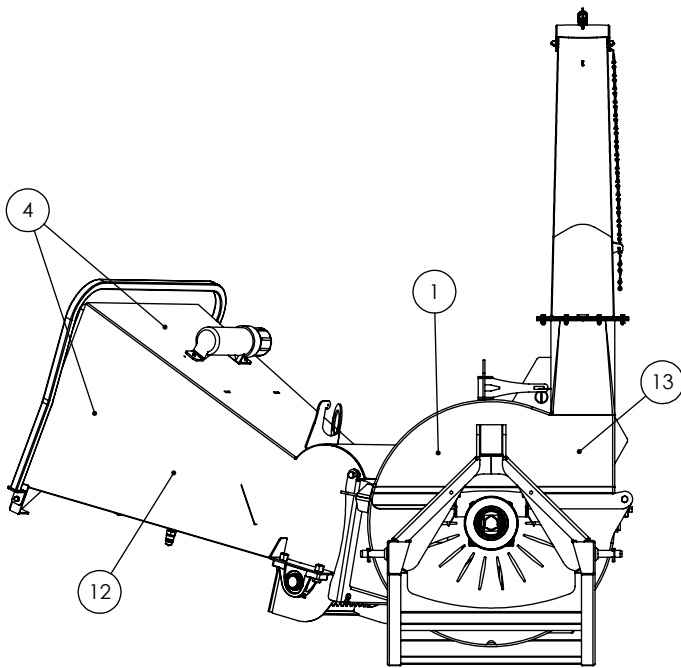

FRONT

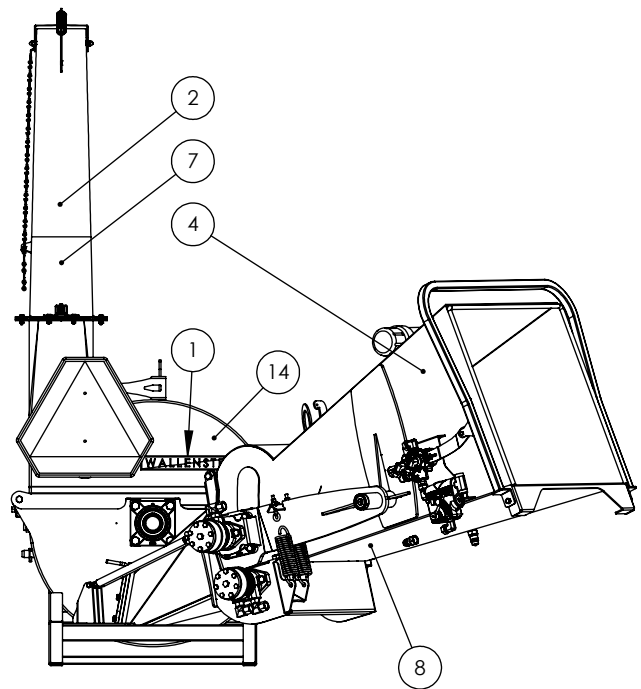

BACK

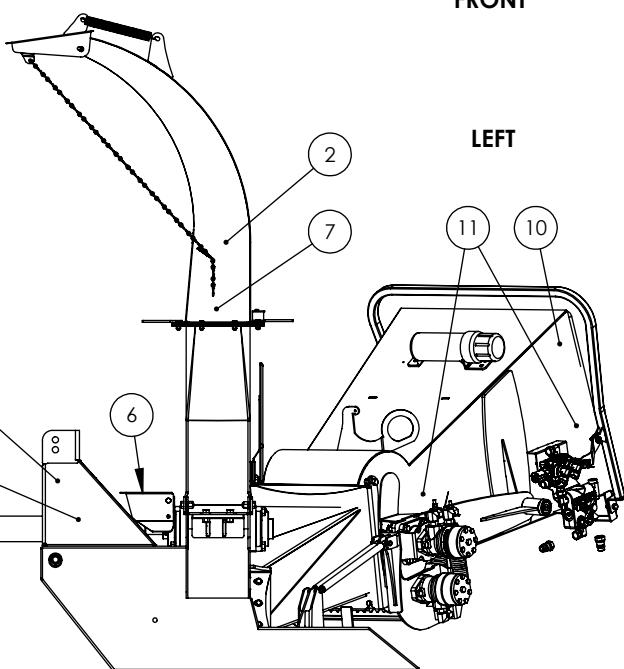

LEFT

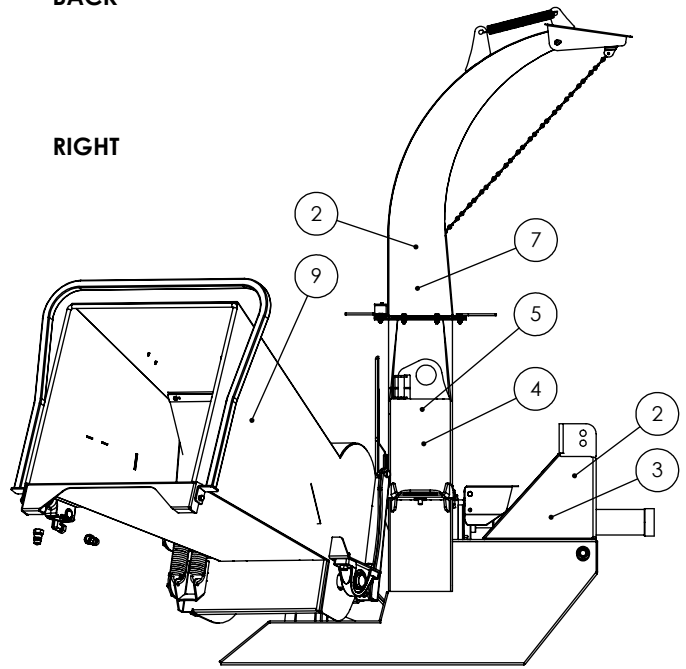

RIGHT

# Two Panel Decals BX62R

Z94056



Z94173



Z94119

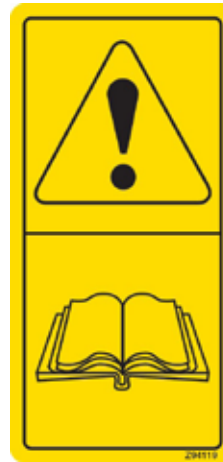

Z94120



Z94117



Z94019



Z94015

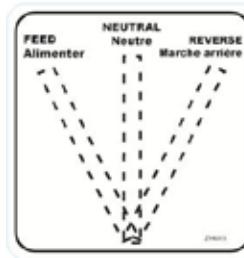

Z94014

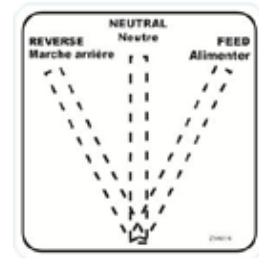

Z94143



Z94167



Z94118



Z94144



Z94602



Z94145

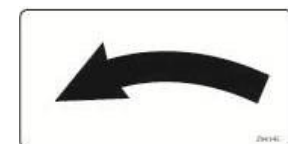





**WALLENSTEIN Products Manufactured by:**

**EMB MFG Inc.**

4144 Boomer Line  
St. Clements, Ontario  
Canada N0B 2M0  
Phone: 1-877-695-9283  
Fax: 519-699-4146  
[www.embmfg.com](http://www.embmfg.com)