

# WALLENSTEIN

BY EMB MFG INC.

EMB Manufacturing Inc.  
4144 Boomer Line · St. Clements, On · N0B 2M0 · Canada  
Ph: (519) 699-9283 · Fax: (519) 699-4146  
[www.wallensteinequipment.com](http://www.wallensteinequipment.com)

## BXT6224 Chipper S/N 2E9US1117FS050202 & After

## BXT6228su Chipper S/N 2E9US111XFS055040 & After

# Parts Manual

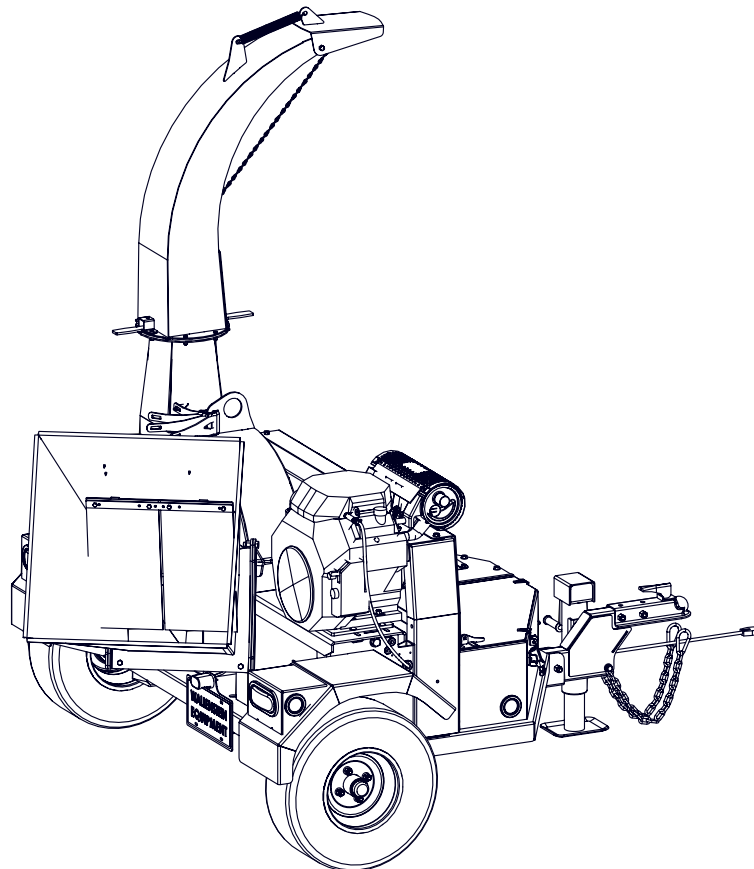

Refer to the operators  
manual for safe  
operation and  
maintenance

1053 BXT6224 BXT6228su RevK1 Parts Manual  
Rev K1 200416

## Foreword

EMB Mfg. has prepared this parts manual to assist customers in ordering quality OEM replacement parts.

Proper and regular service and replacing old, worn or broken parts with the correct OEM parts are essential to prolonging the life of your EMB product. Please refer to this manual before ordering any replacement parts.

All information contained in this parts manual is based on the latest product specification available at the time of printing this manual. If your product differs from the specifications contained within this manual contact EMB Mfg. for information.

EMB reserves the right to alter specifications on their products at any time.

Reproduction of this parts manual of any kind is prohibited without prior written permission from EMB Mfg.

For parts and information please contact your dealer. If your dealer is no longer available please go to our website: <http://www.wallensteinequipment.com> and click on "FIND A DEALER NEAR YOU" for information on a local dealer.

## Table of Contents

<b>Bolt Torque.....</b>	<b>4</b>
<b>Hydraulic Fitting Torque .....</b>	<b>5</b>
<b>Wheel Lug Torque .....</b>	<b>5</b>
<b>Main Frame, Guards, &amp; Battery .....</b>	<b>6</b>
<b>Blower Parts.....</b>	<b>7</b>
<b>Running Gear.....</b>	<b>8</b>
<b>Trailer Tongue Assembly .....</b>	<b>9</b>
<b>Idler Hub Assembly .....</b>	<b>9</b>
<b>Rotor.....</b>	<b>10</b>
<b>Discharge Chute Assembly.....</b>	<b>10</b>
<b>Engine &amp; Driveline.....</b>	<b>11</b>
<b>Fuel Tank Assembly &amp; Fuel Lines.....</b>	<b>12</b>
<b>Self-feed Hopper Flap Detail.....</b>	<b>13</b>
<b>Label Layout.....</b>	<b>14</b>
<b>Accessories.....</b>	<b>16</b>

Maintenance should be performed by  
trained personnel only.



Refer to the operators  
manual for safe  
operation and  
maintenance

**Bolt Torque**

**CHECKING BOLT TORQUE**

The tables shown below give correct torque values for various bolts and capscrews. Tighten all bolts to the torques specified in chart unless otherwise noted. Check tightness of bolts periodically, using bolt torque chart as a guide. Replace hardware with the same strength bolt.

ENGLISH TORQUE SPECIFICATIONS						
Bolt Diameter "A"	Bolt Torque*					
	SAE 2 (N.m) (lb-ft)		SAE 5 (N.m) (lb-ft)		SAE 8 (N.m) (lb-ft)	
1/4"	8	6	12	9	17	12
5/16"	13	10	25	19	36	27
3/8"	27	20	45	33	63	45
7/16"	41	30	72	53	100	75
1/2"	61	45	110	80	155	115
9/16"	95	60	155	115	220	165
5/8"	128	95	215	160	305	220
3/4"	225	165	390	290	540	400
7/8"	230	170	570	420	880	650
1"	345	225	850	630	1320	970

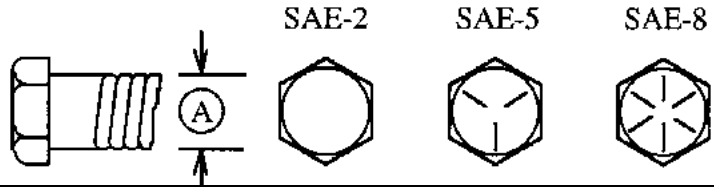

Torque figures indicated above are valid for non-greased or non-oiled threads and heads unless otherwise specified. Therefore, do not grease or oil bolts or capscrews unless otherwise specified in this manual. When using locking elements, increase torque values by 5%.

\* Torque value for bolts and capscrews are identified by their head markings.

METRIC TORQUE SPECIFICATIONS				
Bolt Diameter "A"	Bolt Torque*			
	8.8 (N.m) (lb-ft)		10.9 (N.m) (lb-ft)	
M3	0.5	0.4	1.8	1.3
M4	3	2.2	4.5	3.3
M5	6	4	9	7
M6	10	7	15	11
M8	25	18	35	26
M10	50	37	70	52
M12	90	66	125	92
M14	140	103	200	148
M16	225	166	310	229
M20	435	321	610	450
M24	750	553	1050	774
M30	1495	1103	2100	1550
M36	2600	1917	3675	2710

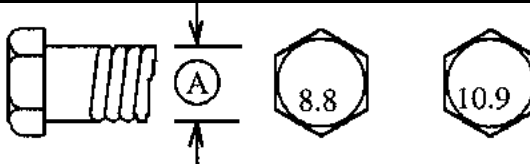

### Hydraulic Fitting Torque

#### Tightening Flare Type Tube Fittings \*

1. Check flare and flare seat for defects that might cause leakage.
2. Align tube with fitting before tightening.
3. Lubricate connection and hand tighten swivel nut until snug.
4. To prevent twisting the tube(s), use two wrenches. Place one wrench on the connector body and with the second tighten the swivel nut to the torque shown.

Tube Size OD (in.)	Nut Size Across Flats (in.)	Torque Value*		Recommended Turns To Tighten (After Finger Tightening)	
		(N.m)	(lb-ft)	(Flats)	(Turn)
3/16	7/16	8	6	1	1/6
1/4	9/16	12	9	1	1/6
5/16	5/8	16	12	1	1/6
<b>3/8</b>	<b>11/16</b>	<b>24</b>	<b>18</b>	<b>1</b>	<b>1/6</b>
1/2	7/8	46	34	1	1/6
5/8	1	62	46	1	1/6
3/4	1-1/4	102	75	3/4	1/8
7/8	1-3/8	122	90	3/4	1/8

The torque values shown are based on lubricated connections as in reassembly.

### Wheel Lug Torque

It is extremely important safety procedure to apply and maintain proper wheel mounting torque on your trailer axle. Torque wrenches are the best method to assure the proper amount of torque is being applied to a fastener.

Wheel lugs should be torqued before first road use and after each wheel removal. Check and re torque after the first 16Km (10 miles), 40Km (25 miles), and again at 80Km (50 miles). Check periodically thereafter.

Note: Wheel lugs must be applied and maintained at the proper torque levels to prevent loose wheels, broken studs, and possible dangerous separation of wheels from your axle.

- Start all lugs by hand to prevent cross threading.
- Tighten lugs in sequence, per wheel lug torque sequence chart.
- The tightening of the fasteners should be done in stages. Following the recommended sequence, tighten fasteners per wheel torque requirements chart.

Wheel Torque Requirements				
Wheel Size	Torque Unit	1st Stage	2nd Stage	3rd Stage
8"	ft-lbs	12 - 20	30 - 35	45 - 55
	Nm	16 - 26	39 - 45.5	58.5 - 71.5
12"	ft-lbs	20 - 25	35 - 40	50 - 60
	Nm	26 - 32.5	45.5 - 52	65 - 78
13"	ft-lbs	20 - 25	35 - 40	50 - 60
	Nm	26 - 32.5	45.5 - 52	65 - 78
14"	ft-lbs	20 - 25	50 - 60	90 - 120
	Nm	26 - 32.5	65 - 78	117 - 156
15"	ft-lbs	20 - 25	50 - 60	90 - 120
	Nm	26 - 32.5	65 - 78	117 - 156
16"	ft-lbs	20 - 25	50 - 60	90 - 120
	Nm	26 - 32.5	65 - 78	117 - 156

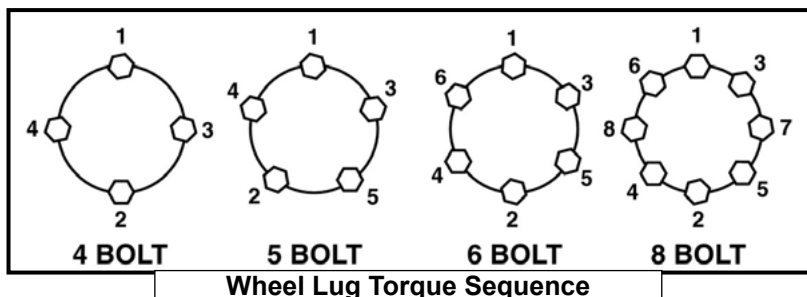

**Main Frame, Guards, & Battery**

Note:  
Items 13, 23 & 28 are not on  
the BXT6228su Model

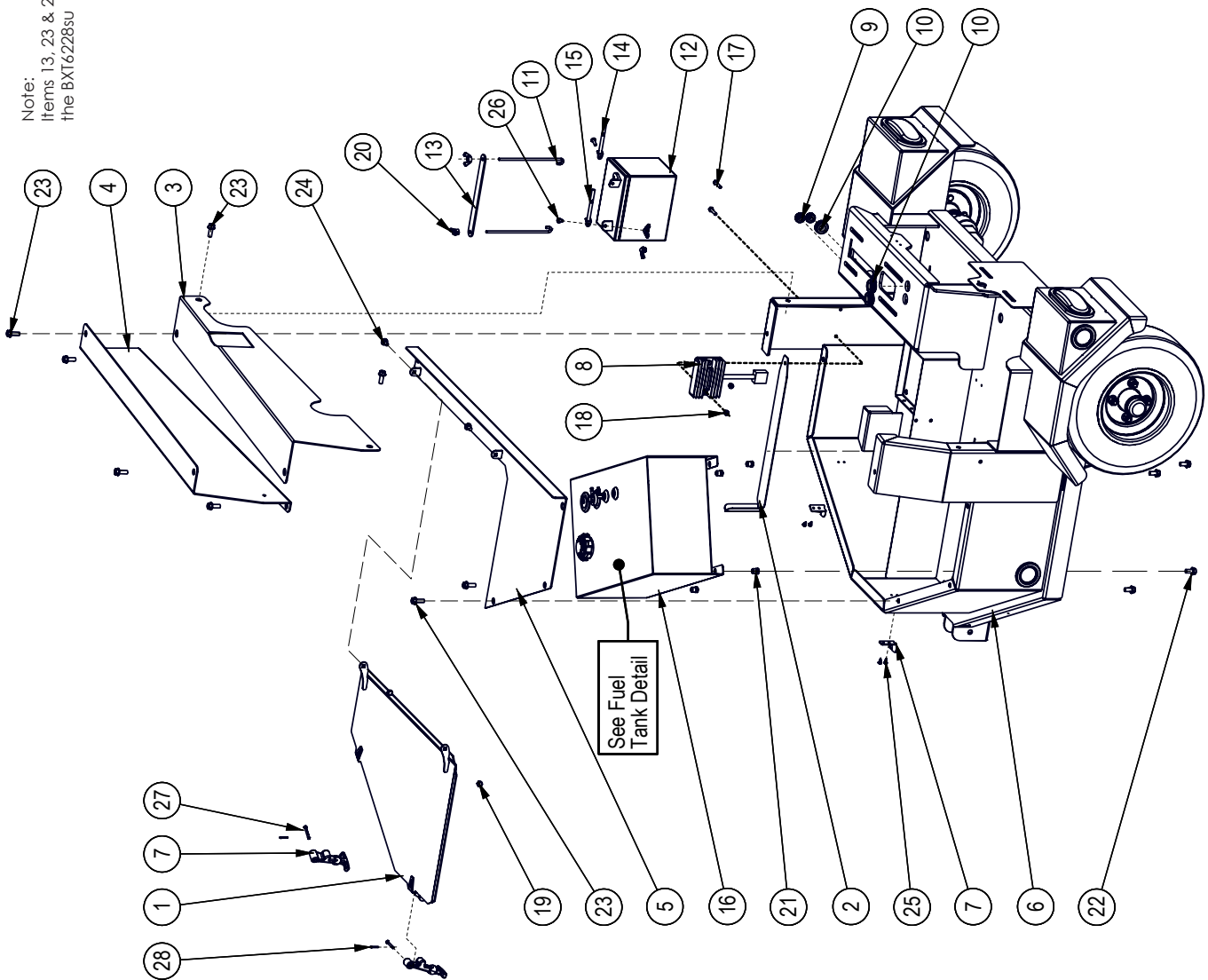

Item No.	Part No.	Description	Qty
1	1052A104	Toolbox Lid	1
2	1012L269	Gauge, Ledger Setting	1
3	1052L122	Rear Belt Guard	1
4	1052L125	Front Belt Guard	1
5	1052W106	Weldment, Bay Cover	1
6	1052W502	Main Frame	1
7	Z18201	Hood Fastener	2
8	Z47901	Regulator Rectifier	1
9	Z62808	Rubber Grommet, 7/16" x 1/4"	2
10	Z62822	Rubber Grommet, 3/4" x 1/4"	3
11	Z93202	J-Hook, 1/4" x 7"	2
12	Z93204	Battery, 325CCA	1
13	Z93207	Hold-Down Strap, 1" x 8-1/2"	1
14	Z93210	Battery Cable, Negative x 25"	1
15	Z93212	Battery Cable, Positive x 28"	1
16	1052A501	Fuel Tank, Trailer Chippers EPA	1
17	Z71112	Hex Bolt, 1/4NC x 1-1/4"	2
18	Z72211	Hex Lock Nut, 1/4NC	2
19	Z72914	Acorn Nut, 5/16NC	2
20	Z72921	Wing Nut, 1/4NC	4
21	Z72959	Rivet Nut, 3/8NC x 150	4
22	Z76133	Flange Bolt, 3/8NC x 3/4"	4
23	Z76134	Flange Bolt, 3/8NC x 1"	8
24	Z76221	Carriage Bolt, 5/16NC x 3/4"	2
25	Z76711	Self-tapping Screw, #10 x 1/2"	4
26	Z76301	Machine Screw, 1/4NC x 3/4"	2
27	Z11300	Clevis Pin 3/16 x 1-3/8	2
28	Z12300	Cotter Pin 3/32 X 3/4	2

**Blower Parts**

BOM ID	Part No.	Description	Qty
1	1012A202	Self-feed Hopper	1
2	1053W202	Housing, Upper Rotor	1
3	1012W204	Twig Breaker	1
4	Z12110	Lynch Pin, 3/16"	1
5	Z71512	Hex Bolt, 1/2NC x 1-1/4"	4
6	Z71515	Hex Bolt, 1/2NC x 1-1/2"	2
7	Z72251	Hex Lock Nut, 1/2NC	6
8	Z72531	Serrated Flange Locknut, 3/8NC	2
9	Z76152	Flange Bolt, 1/2NC x 1-1/4"	1
10	1012A201	Assembly, Discharge Chute	1

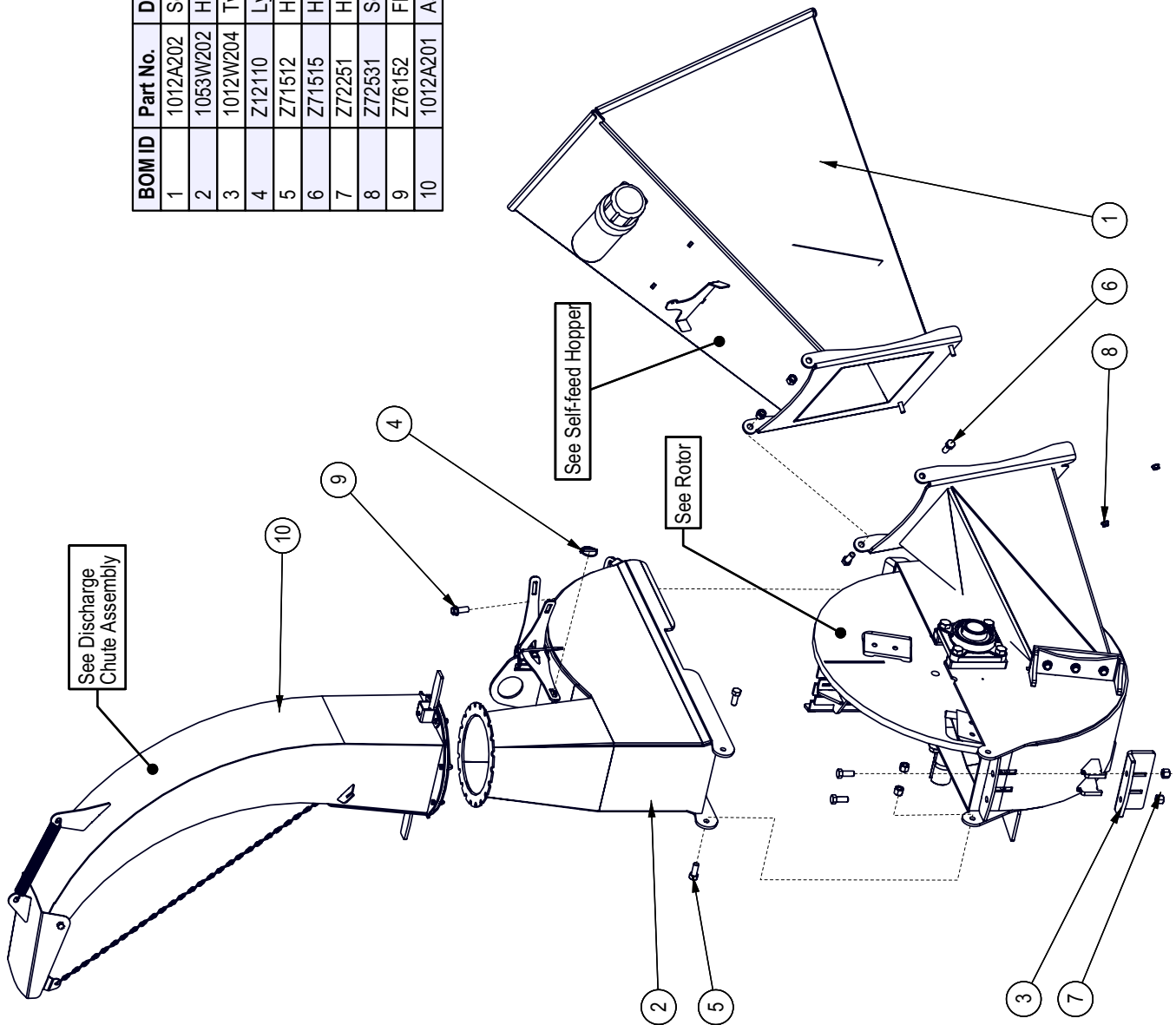

**Running Gear**

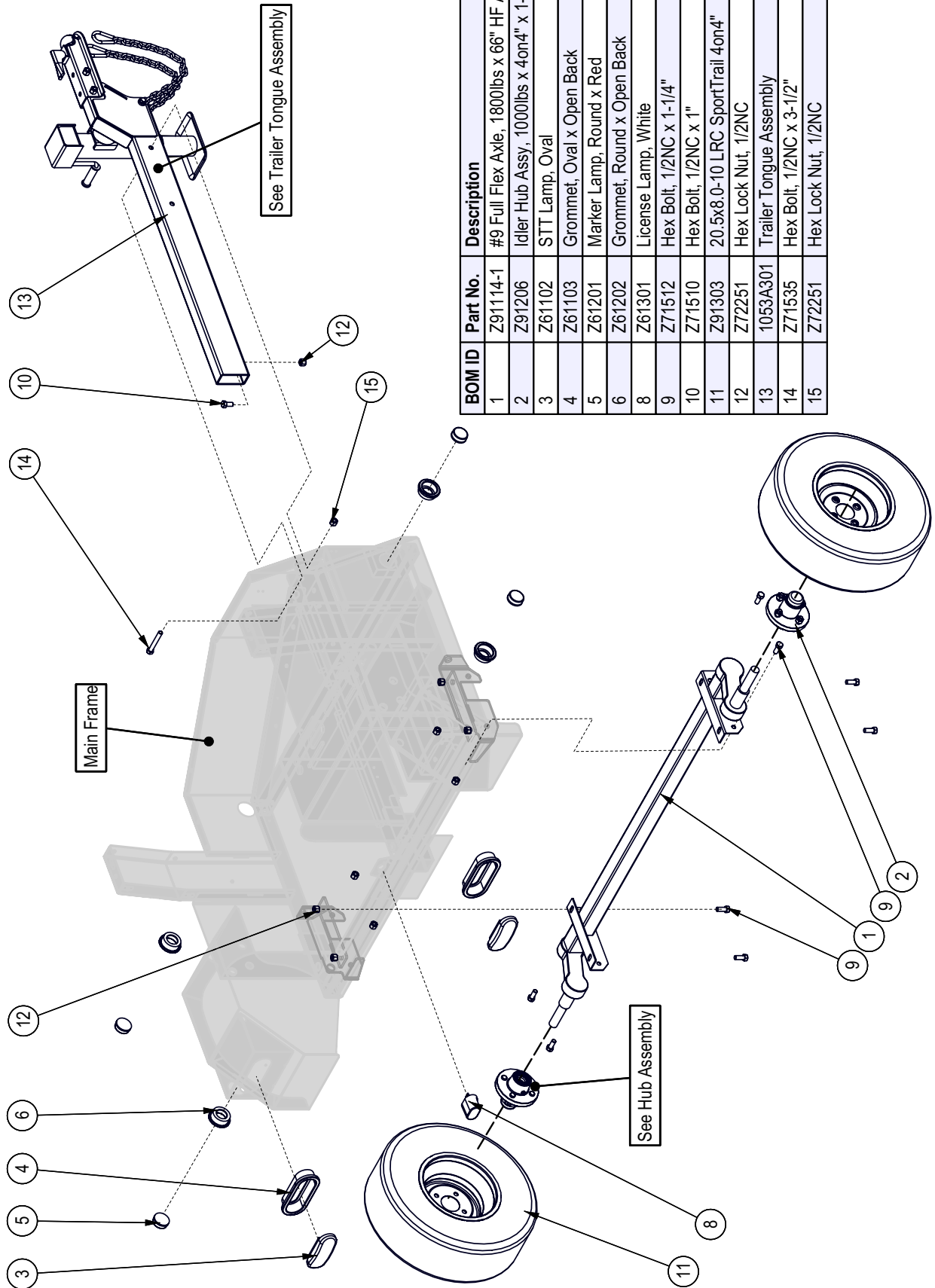

BOM ID	Part No.	Description	Qty
1	Z9114-1	#9 Full Flex Axle, 1800lbs x 66" HF Axle Only	1
2	Z91206	Idler Hub Assy, 1000lbs x 4on4" x 1-1/16"	2
3	Z61102	STT Lamp, Oval	2
4	Z61103	Grommet, Oval x Open Back	2
5	Z61201	Marker Lamp, Round x Red	2
6	Z61202	Grommet, Round x Open Back	4
8	Z61301	License Lamp, White	1
9	Z71512	Hex Bolt, 1/2NC x 1-1/4"	8
10	Z71510	Hex Bolt, 1/2NC x 1"	1
11	Z91303	20.5x8.0-10 LRC SportTrail 4on4"	2
12	Z72251	Hex Lock Nut, 1/2NC	9
13	1053A301	Trailer Tongue Assembly	1
14	Z71535	Hex Bolt, 1/2NC x 3-1/2"	1
15	Z72251	Hex Lock Nut, 1/2NC	1



**Trailer Tongue Assembly**

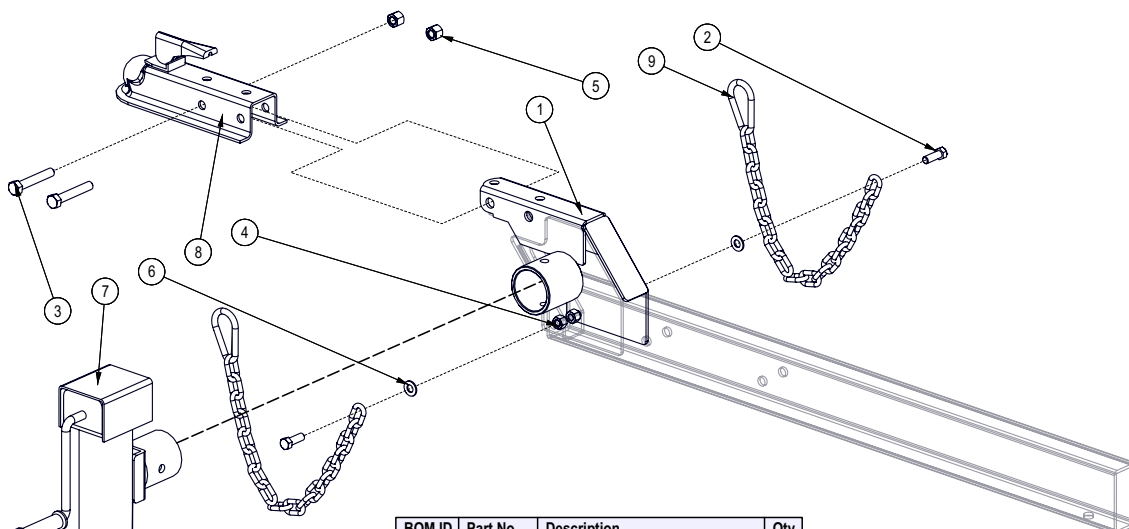

BOM ID	Part No.	Description	Qty
1	1053W301	Tongue Weldment	1
2	Z71412	Hex Bolt, 7/16NC x 1-1/4"	2
3	Z71530	Hex Bolt, 1/2NC x 3"	2
4	Z72241	Hex Lock Nut, 7/16NC	2
5	Z72251	Hex Lock Nut, 1/2NC	2
6	Z73142	SAE Washer, 7/16"	2
7	Z91512	Trailer Jack, Side Wind x 2000lbs	1
8	Z91614	Hitch Coupler, 2" Ball x 2" x 3500lbs	1
9	Z92303	Safety Chain, 1/4" x 2ft with Snap	2

**Idler Hub Assembly**

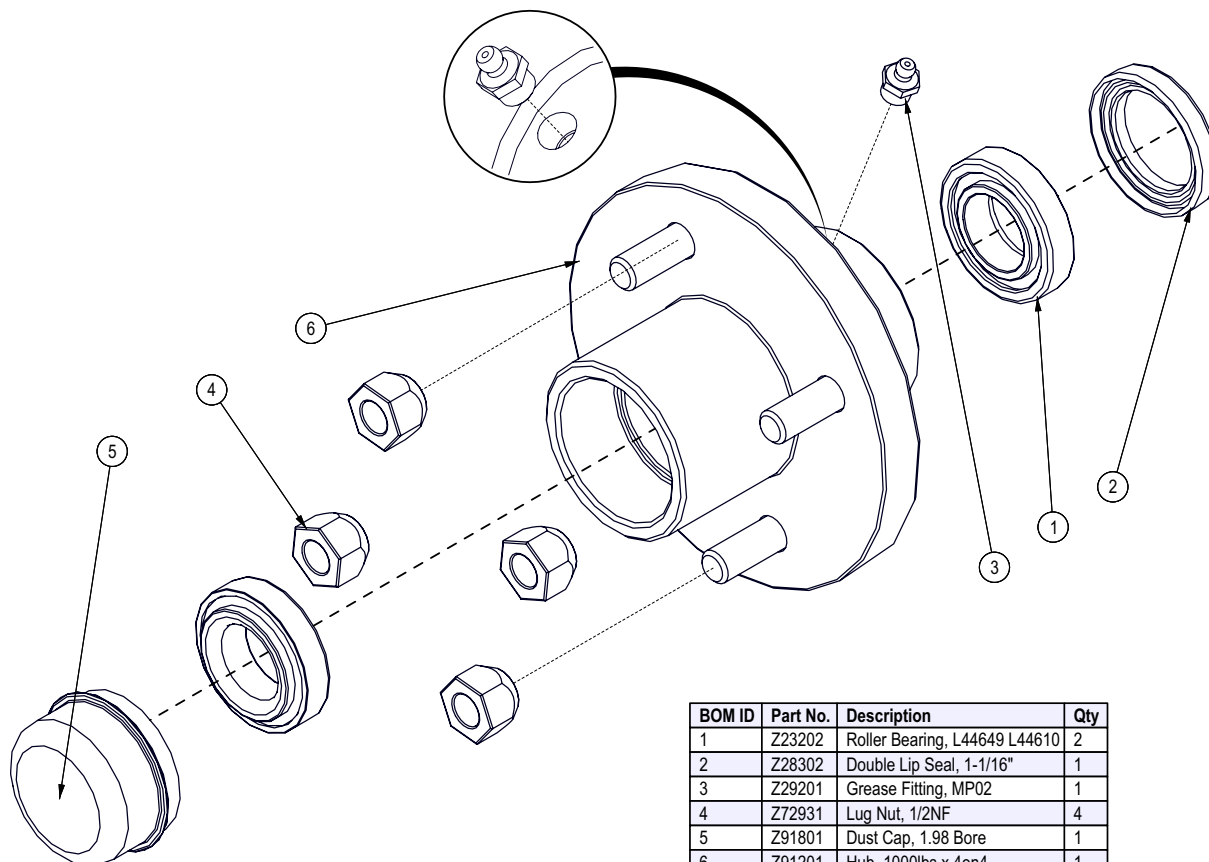

BOM ID	Part No.	Description	Qty
1	Z23202	Roller Bearing, L44649 L44610	2
2	Z28302	Double Lip Seal, 1-1/16"	1
3	Z29201	Grease Fitting, MP02	1
4	Z72931	Lug Nut, 1/2NF	4
5	Z91801	Dust Cap, 1.98 Bore	1
6	Z91201	Hub, 1000lbs x 4on4	1

**Rotor**

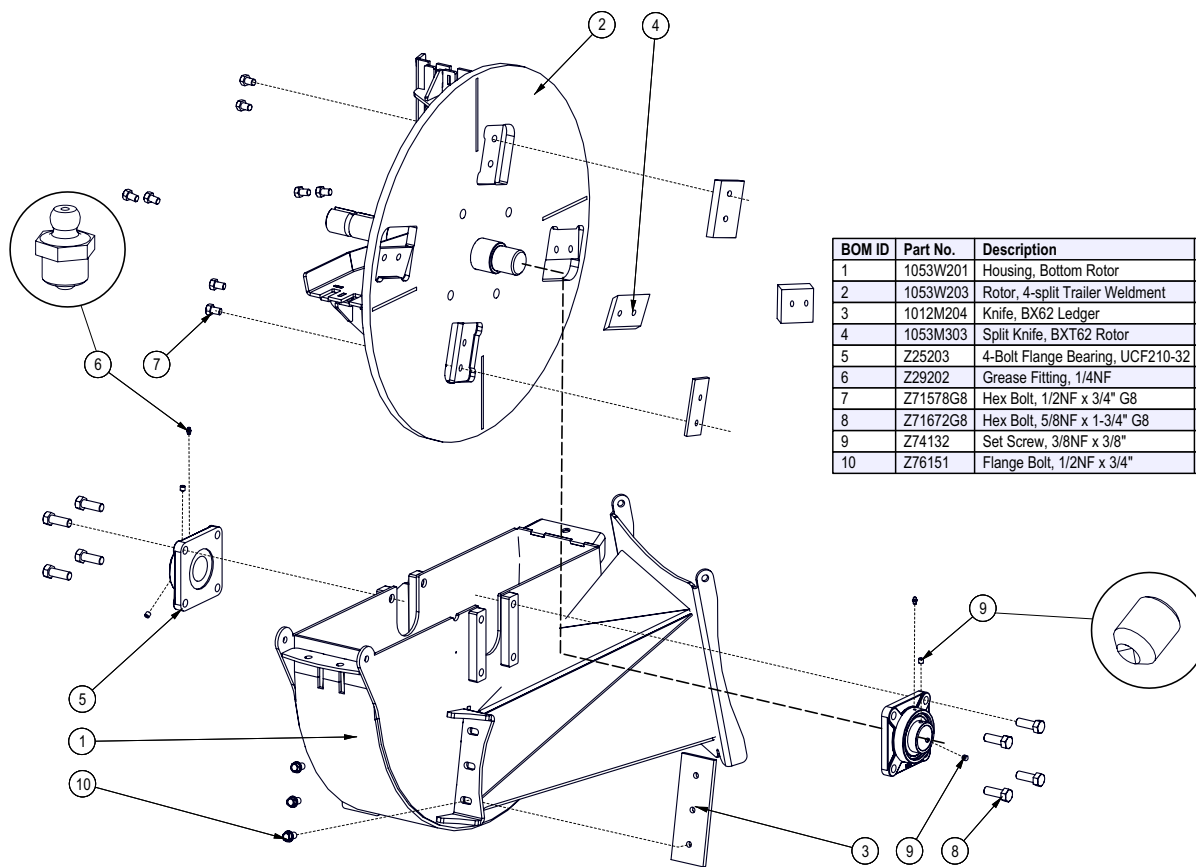

BOM ID	Part No.	Description	Qty
1	1053W201	Housing, Bottom Rotor	1
2	1053W203	Rotor, 4-split Trailer Weldment	1
3	1012M204	Knife, BX62 Ledger	1
4	1053M303	Split Knife, BXT62 Rotor	4
5	Z25203	4-Bolt Flange Bearing, UCF210-32	2
6	Z29202	Grease Fitting, 1/4NF	2
7	Z71578G8	Hex Bolt, 1/2NF x 3/4" G8	8
8	Z71672G8	Hex Bolt, 5/8NF x 1-3/4" G8	8
9	Z74132	Set Screw, 3/8NF x 3/8"	4
10	Z76151	Flange Bolt, 1/2NF x 3/4"	3

**Discharge Chute Assembly**

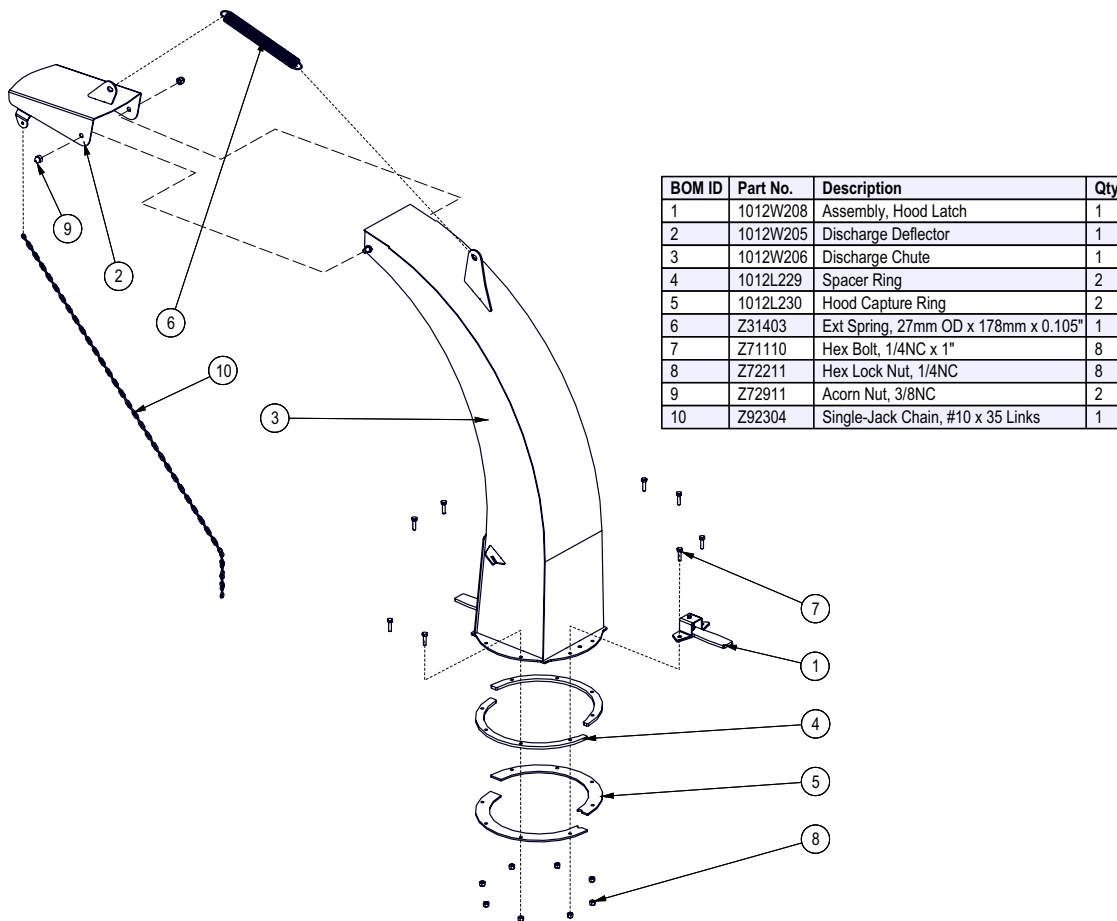

BOM ID	Part No.	Description	Qty
1	1012W208	Assembly, Hood Latch	1
2	1012W205	Discharge Deflector	1
3	1012W206	Discharge Chute	1
4	1012L229	Spacer Ring	2
5	1012L230	Hood Capture Ring	2
6	Z31403	Ext Spring, 27mm OD x 178mm x 0.105"	1
7	Z71110	Hex Bolt, 1/4NC x 1"	8
8	Z72211	Hex Lock Nut, 1/4NC	8
9	Z72911	Acorn Nut, 3/8NC	2
10	Z92304	Single-Jack Chain, #10 x 35 Links	1

**Engine & Driveline**

BOM ID	Part No.	Description	Qty
1	1052L503	Washer, Clutch Trap x 7/16"	1
2	Z41254	Double "B" Belt x 87	1
3	Z41512	Hub, SK x 2"	1
4	Z41702	Double Sheave, 2B124 x SK	1
5	Z41902	Centrifugal Clutch, 2B39 x 1-1/8"	1
6	Z46353	Spacer, 1-1/8" ID x 1.065"	1
7	Z46532	Key, 1/4" x 1/4" x 1-1/2"	1
8	Z46561	Key, 1/2" x 1/2" x 2"	1
9	Z47169	Aftermarket Muffler, GX690 (Ignition Side)	1
10	Z71220	Hex Bolt, 5/16NC x 2"	3
11	Z71472	Hex Bolt, 7/16NF x 1-1/2"	1
12	Z71660	Hex Bolt, 5/8NC x 6"	1
13	Z72231	Hex Lock Nut, 3/8NC	8
14	Z73131	SAE Washer, 3/8"	8
15	Z73161	SAE Washer, 5/8"	1
16	Z74111	Set Screw, 1/4NC x 1/4"	1
17	Z76232	Carriage Bolt, 3/8NC x 1-1/4"	4
18	Z76632	Plow Bolt, 3/8NC x 2"	4
19	Z93314	Plastic Reducer, HB x HB 0403	1
20	1053W304	Engine Adjustment Plate	1
21	Z47168	Honda GX690RTXF, Rope - BXT6224	1
	Z47709	Subaru EHT22DSF010, Electric - BXT6228su	1

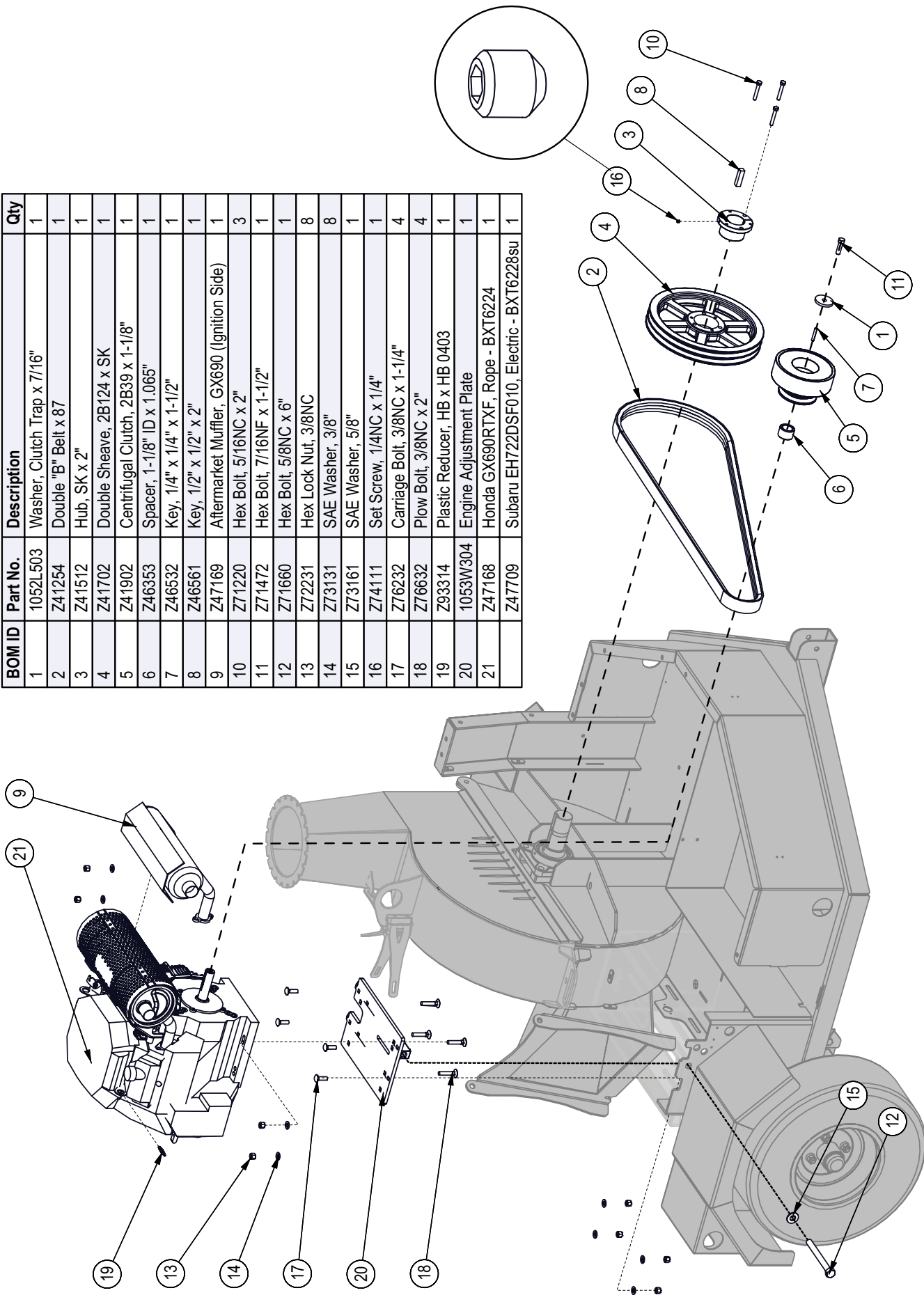

**Fuel Tank Assembly & Fuel Lines**

BOM ID	Part No.	Description	Qty
1	1062S501	Fuel Pickup Tube	1
2	1052W501	Fuel Tank, Trailer Chipper	1
3	Z51194	Socket Plug, MP 04	1
4	Z62821	Rubberized Wire Clamp, 5/8"	2
5	Z73111	SAE Washer, 1/4"	2
6	Z76712	Self-tapping Screw, #10 x 3/4"	2
7	Z77130	Hex Bolt, M6x1.0 x 14mm	2
8	Z79405	Hose Clamp, SAE #4 (5/8") BXT6224	8
11	Z79405	Hose Clamp, SAE #4 (5/8") BXT6228su	11
9	Z93108	EPA Ratchet Fuel Cap, Unleaded Fuel x Unvented with Teether	1
10	Z93110	EPA Remote Vent, HB04	1
11	Z93111	Vent Grommet For Z93110	1
12	Z93113	Fuel Gauge, Grommet Mount x 7"	1
13	Z93115	Fuel Gauge Grommet for Z93113	1

BOM ID	Part No.	Description	Qty
14	Z93307	EPA Fuel Line, 1/4" x 55" BXT6228su	1
15	Z93307	EPA Fuel Line, 1/4" x 8"	1
16	Z93309	EPA Carbon Canister, 652cc	1
17	Z93310	EPA Fuel Line, 3/16" x 68" BXT6224 A	1
18	Z93310	EPA Fuel Line, 3/16" x 69" BXT6228su B	1
19	Z93312	Plastic Elbow 90, MP x HB 0404 BXT6224 A	1
20	Z93312	Plastic Elbow 90, MP x HB 0404 BXT6228su	2
19	Z93313	Fuel Line, 3/8" ID x 3" BXT6224 Only	1
20	Z93314	Plastic Reducer, HB x HB 0403 BXT6224 Only	1
21	Z93317	Plastic Coupling, HB x HB 0404 BXT6228su Only	1
22	Z93301	Fuel Shut-Off Valve, 1/4" BXT6228su Only	1
23	Z93307	EPA Fuel Line, 1/4" ID x 4" BXT6228su Only	1
24	Z93307	EPA Fuel Line, 1/4" x 50" BXT6224 A	1
24	Z93307	EPA Fuel Line, 1/4" x 52" BXT6228su B	1

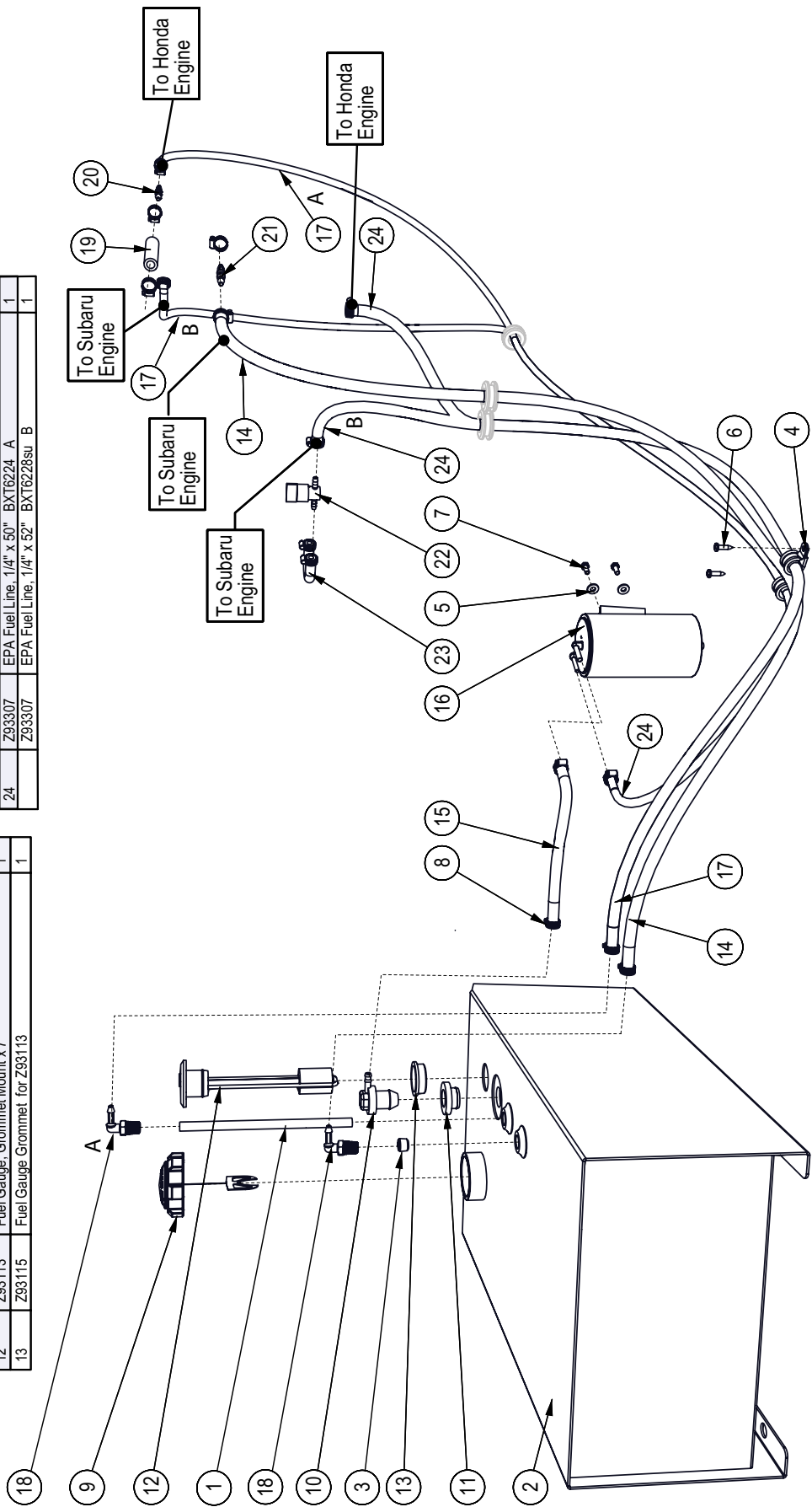

**Self-feed Hopper Flap Detail**

BOM ID	Part No.	Description	Qty
1	1011S103	Flap, Hopper	2
2	1012L251	Strap, Hopper Flap	1
3	Z71107	Hex Bolt, 1/4NC x 3/4"	4
4	Z71312	Hex Bolt, 3/8NC x 1-1/4"	2
5	Z78301	Machine Screw, 1/4NC x 3/4"	3
6	Z96503	Manual Tube, 3-1/2" Short	1
7	1012W207	Hopper, Self-Feed BX62	1
8	Z72211	Hex Lock Nut, 1/4NC	3

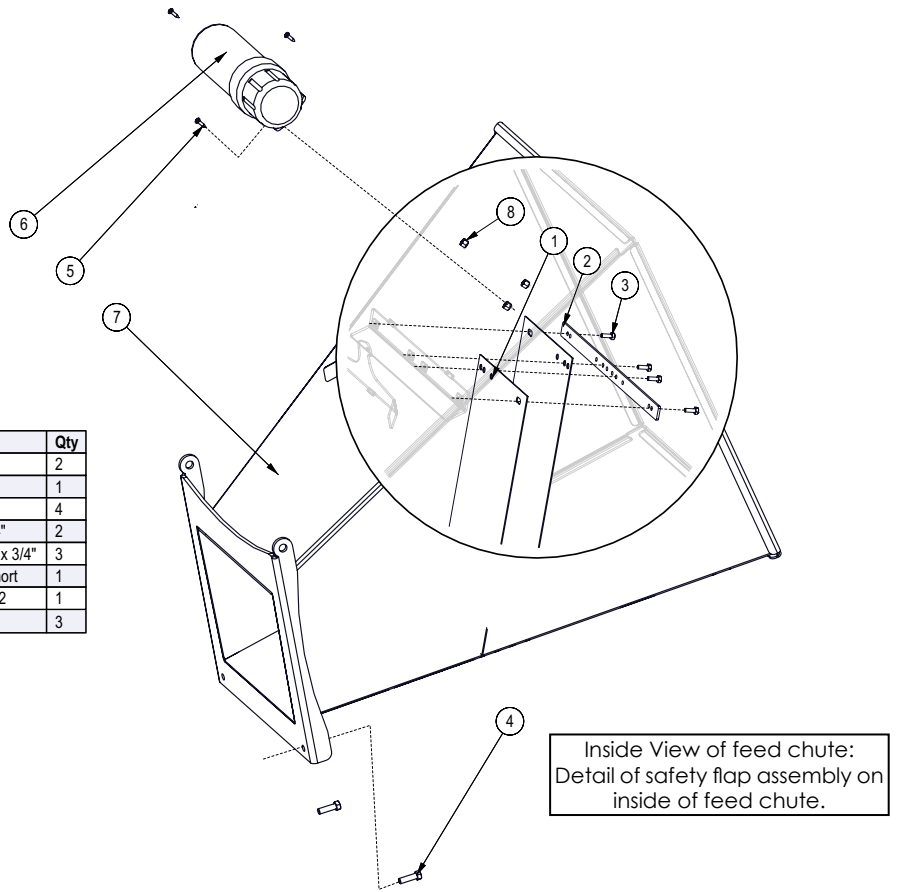

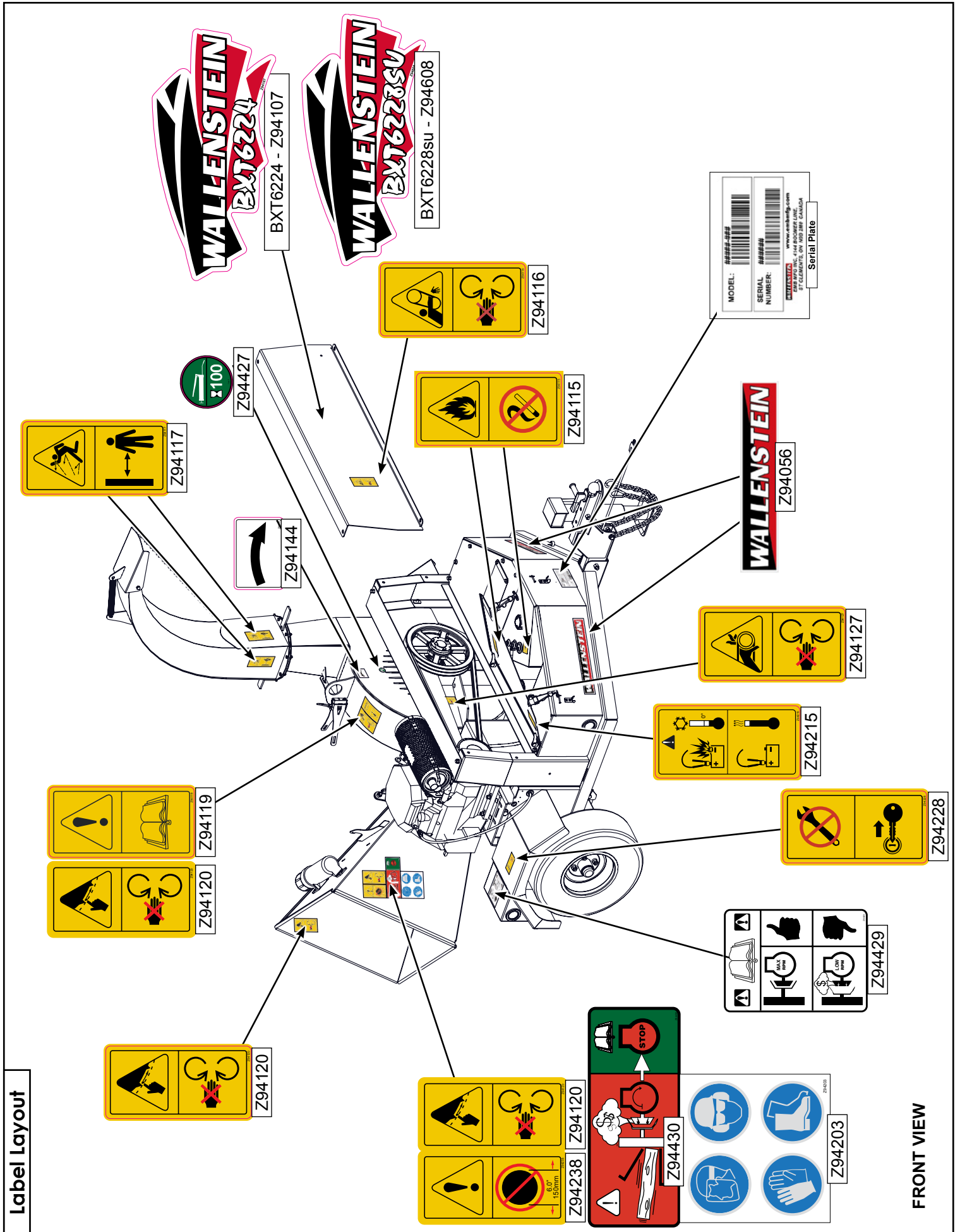

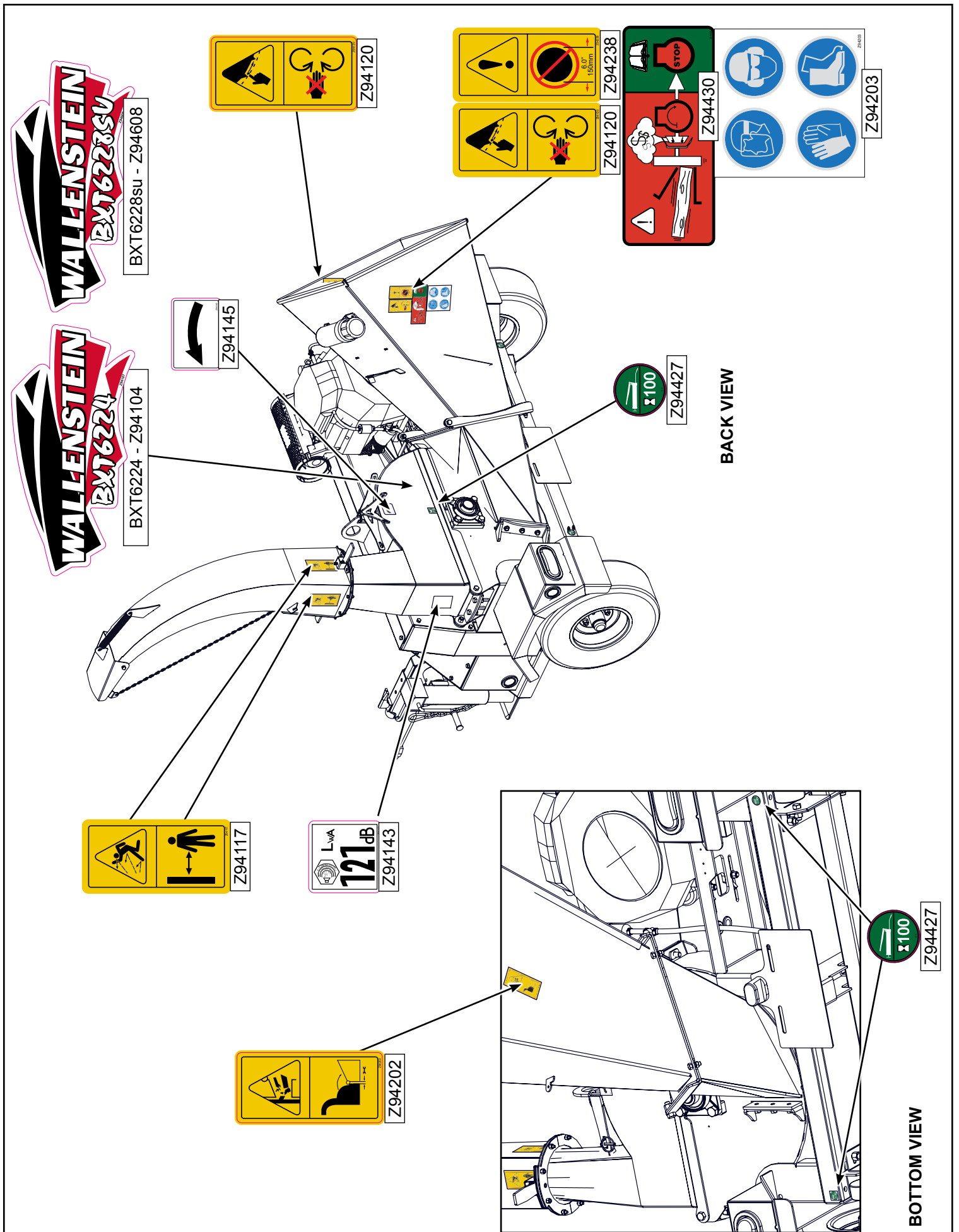

**Accessories**

Call your dealer for pricing and availability

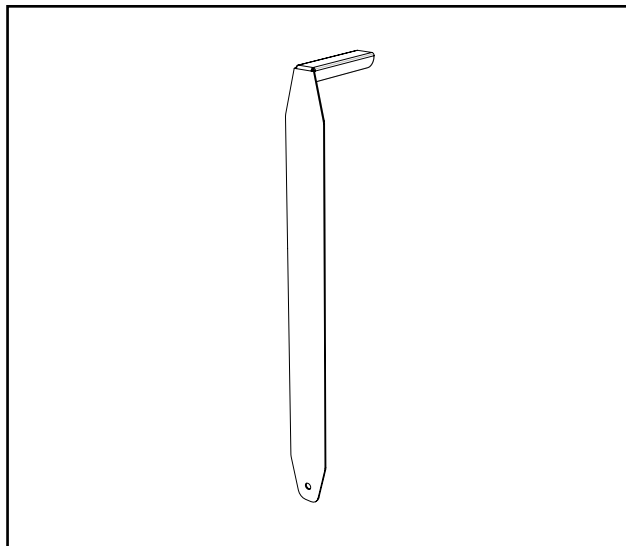

**#1012L269 LEDGER CLEARANCE SETTING GAUGE**



**#Z97033  
TRAILER WOOD CHIPPER  
OPERATOR'S MANUAL**

Available as a download at  
[www.wallensteinequipment.com](http://www.wallensteinequipment.com)