



EMB Manufacturing Inc.
4144 Boomer Line · St. Clements, On · N0B 2M0 · Canada
Ph: (519) 699-9283 · Fax: (519) 699-4146
www.embmfg.com

WX930 Trailer Log Splitter Parts Manual

S/N 2E9US1114ES340007 & After
340007 & After



Refer to the operators
manual for safe opera-
tion and maintainance

2057T100 WX930 Parts Manual
Rev F 281114

Foreword

EMB Mfg. has prepared this parts manual to assist customers in ordering quality OEM replacement parts.

Proper and regular service and replacing old, worn or broken parts with the correct Wallenstein parts are essential to prolonging the life of your Wallenstein product. Please refer to this manual before ordering any replacement parts.

All information contained in this parts manual is based on the latest product specification available at the time of printing this manual. If your product differs from the specifications contained within this manual contact EMB Mfg. for information.

EMB reserves the right to alter specifications on their products at any time.

Reproduction of this parts manual of any kind is prohibited without prior written permission from EMB Mfg.

Note: Products with factory installed light kits will have a VIN number included. The last six numbers of this VIN number are the splitters serial number

Example: 2E9US1112BSXXXXXX

Table of Contents

Bolt Torque	4
Hydraulic Fitting Torque	5
Engine & Pump	6
Cylinder	6
Main Parts	7
Valve	8
Valve & Fittings	10
Hub	10
4-Way Wedge (Optional)	11
Light Kit (Optional)	12
Decal Breakdown	14

Bolt Torque

CHECKING BOLT TORQUE

The tables shown below give correct torque values for various bolts and capscrews. Tighten all bolts to the torques specified in chart unless otherwise noted. Check tightness of bolts periodically, using bolt torque chart as a guide. Replace hardware with the same strength bolt.

Torque figures indicated above are valid for non-greased or non-oiled threads and heads unless otherwise specified. Therefore, do not grease or oil bolts or capscrews unless otherwise specified in this manual. When using locking elements, increase torque values by 5%.

* Torque value for bolts and capscrews are identified by their head markings.

ENGLISH TORQUE SPECIFICATIONS

Bolt Diameter "A"	Bolt Torque*					
	SAE 2 (N.m) (lb-ft)		SAE 5 (N.m) (lb-ft)		SAE 8 (N.m) (lb-ft)	
1/4"	8	6	12	9	17	12
5/16"	13	10	25	19	36	27
3/8"	27	20	45	33	63	45
7/16"	41	30	72	53	100	75
1/2"	61	45	110	80	155	115
9/16"	95	60	155	115	220	165
5/8"	128	95	215	160	305	220
3/4"	225	165	390	290	540	400
7/8"	230	170	570	420	880	650
1"	345	225	850	630	1320	970

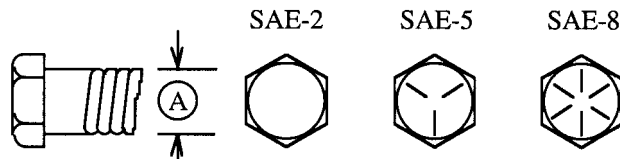

METRIC TORQUE SPECIFICATIONS

Bolt Diameter "A"	Bolt Torque*			
	8.8 (N.m) (lb-ft)		10.9 (N.m) (lb-ft)	
M3	.5	.4	1.8	1.3
M4	3	2.2	4.5	3.3
M5	6	4	9	7
M6	10	7	15	11
M8	25	18	35	26
M10	50	37	70	52
M12	90	66	125	92
M14	140	103	200	148
M16	225	166	310	229
M20	435	321	610	450
M24	750	553	1050	774
M30	1495	1103	2100	1550
M36	2600	1917	3675	2710

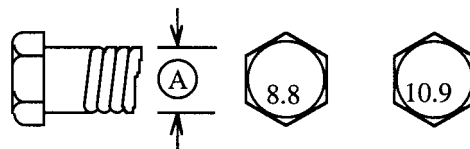

Hydraulic Fitting Torque

Tightening Flare Type Tube Fittings *

1. Check flare and flare seat for defects that might cause leakage.
2. Align tube with fitting before tightening.
3. Lubricate connection and hand tighten swivel nut until snug.
4. To prevent twisting the tube(s), use two wrenches. Place one wrench on the connector body and with the second tighten the swivel nut to the torque shown.

Tube Size OD	Nut Size Across Flats	Torque Value*		Recommended Turns To Tighten (After Finger Tightening)	
		(N.m)	(lb-ft)	(Flats)	(Turn)
3/16	7/16	8	6	1	1/6
1/4	9/16	12	9	1	1/6
5/16	5/8	16	12	1	1/6
3/8	11/16	24	18	1	1/6
1/2	7/8	46	34	1	1/6
5/8	1	62	46	1	1/6
3/4	1-1/4	102	75	3/4	1/8
7/8	1-3/8	122	90	3/4	1/8

The torque values shown are based on lubricated connections as in reassembly.

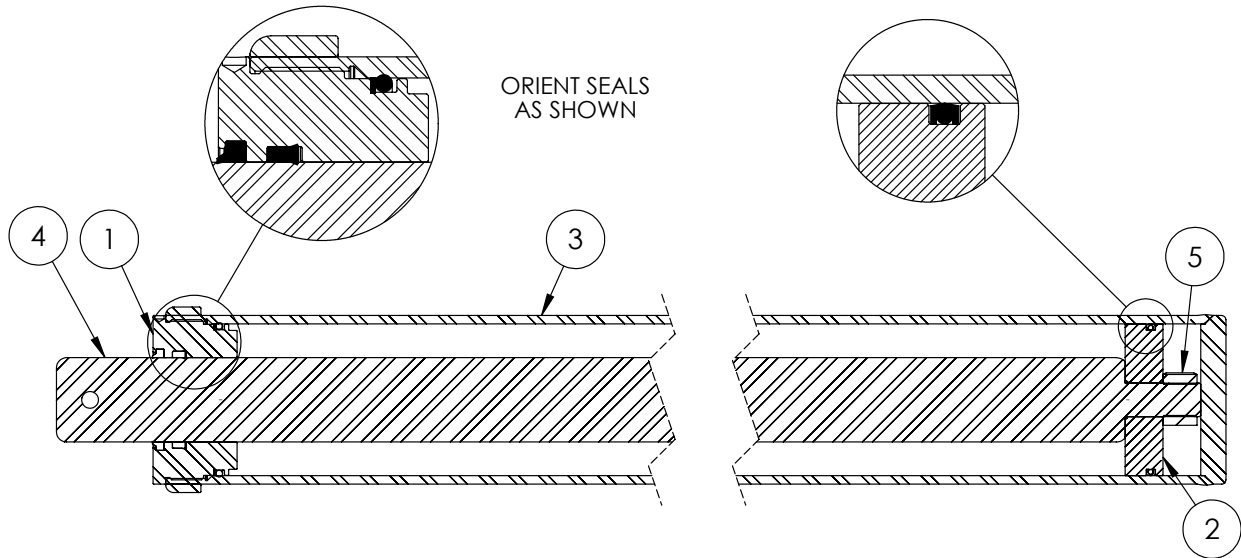

4-1/2" x 48" STROKE CYLINDER PARTS

ITEM	PART NO.	DESCRIPTION	QTY
1	G450-250SA	4-1/2" Bore x 2-1/2" Rod Gland With Seals	1
2	P100-450SA	4-1/2" Bore Piston With Seals	1
3	2013C3014	Barrel, 4-1/2"	1
4	2013C3012	Rod, 2-1/2x 1	1
5	Z72292G8	Hex Lock Nut 1NF Grade 8	1
6	SLK-4525	Seal Kit, 4-1/2 x 2-1/2	1

2061A103 9hp ENGINE / PUMP ASSEMBLY PARTS

ITEM	PART NO.	DESCRIPTION	QTY
1	Z47136	Honda 9hp Engine	1
2	Z53802	Pump Mounting, PM-9	1
3	Z46404	Shaft Coupler L095 x 1	1
4	Z46405	Coupler Spider L095	1
5	Z46409	Shaft Coupler L095 x 1/2	1
6	Z53205	Pump, 16gpm Two-Stage	1
7	Z51331	Elbow 90 MP x FPX 0808	1
8	Z71210	Hex Bolt 5/16NC x 1	4
9	Z46533	Key 1/4 x 1/4 x 1	1
10	Z46592	Woodruff Key, 1/8 x 1/2	1
11	Z71274	Hex Bolt, 5/16NF x 1	4
12	Z71320	Hex Bolt 3/8NC x 2	4
13	Z72231	Hex Lock Nut 3/8NC	4

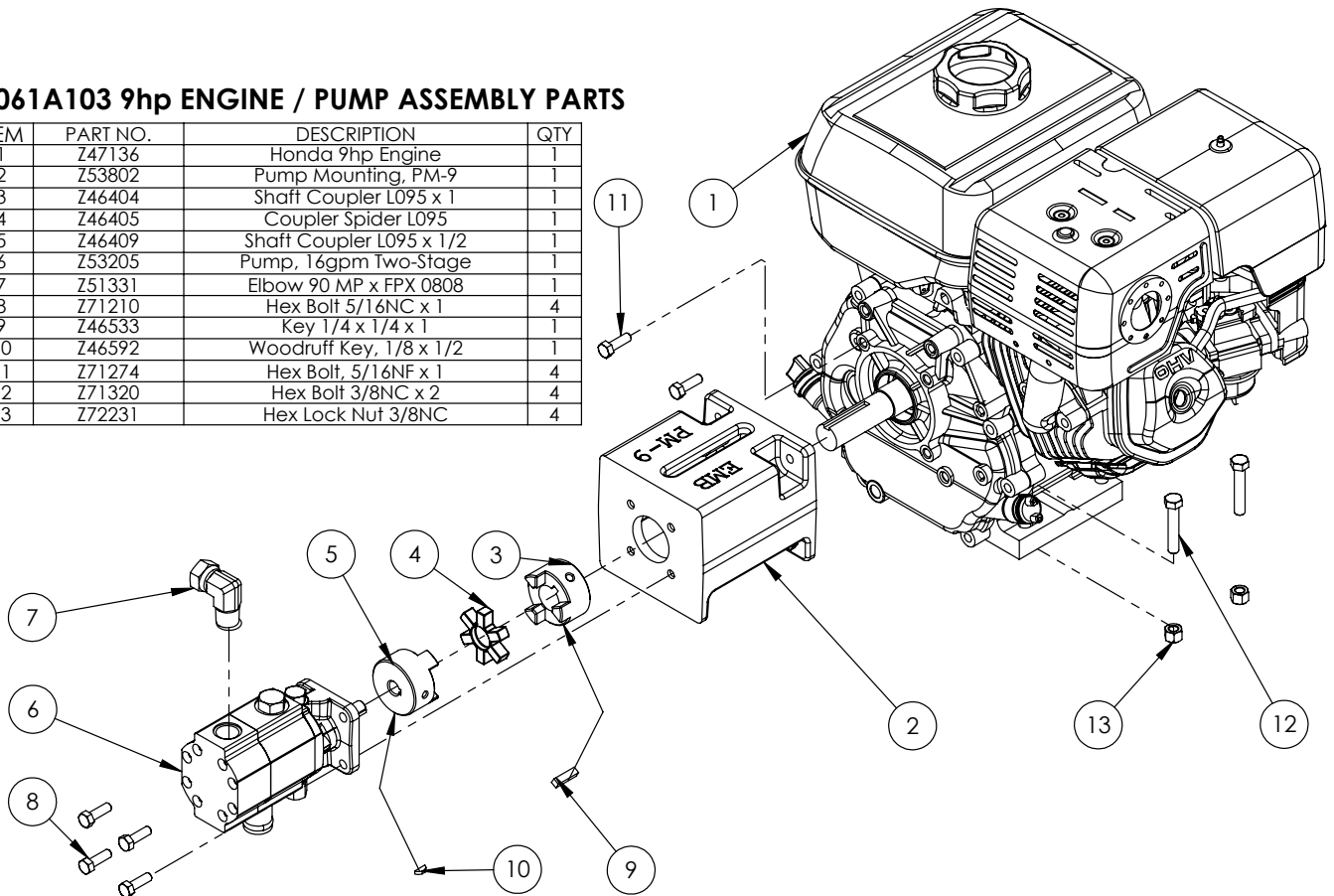

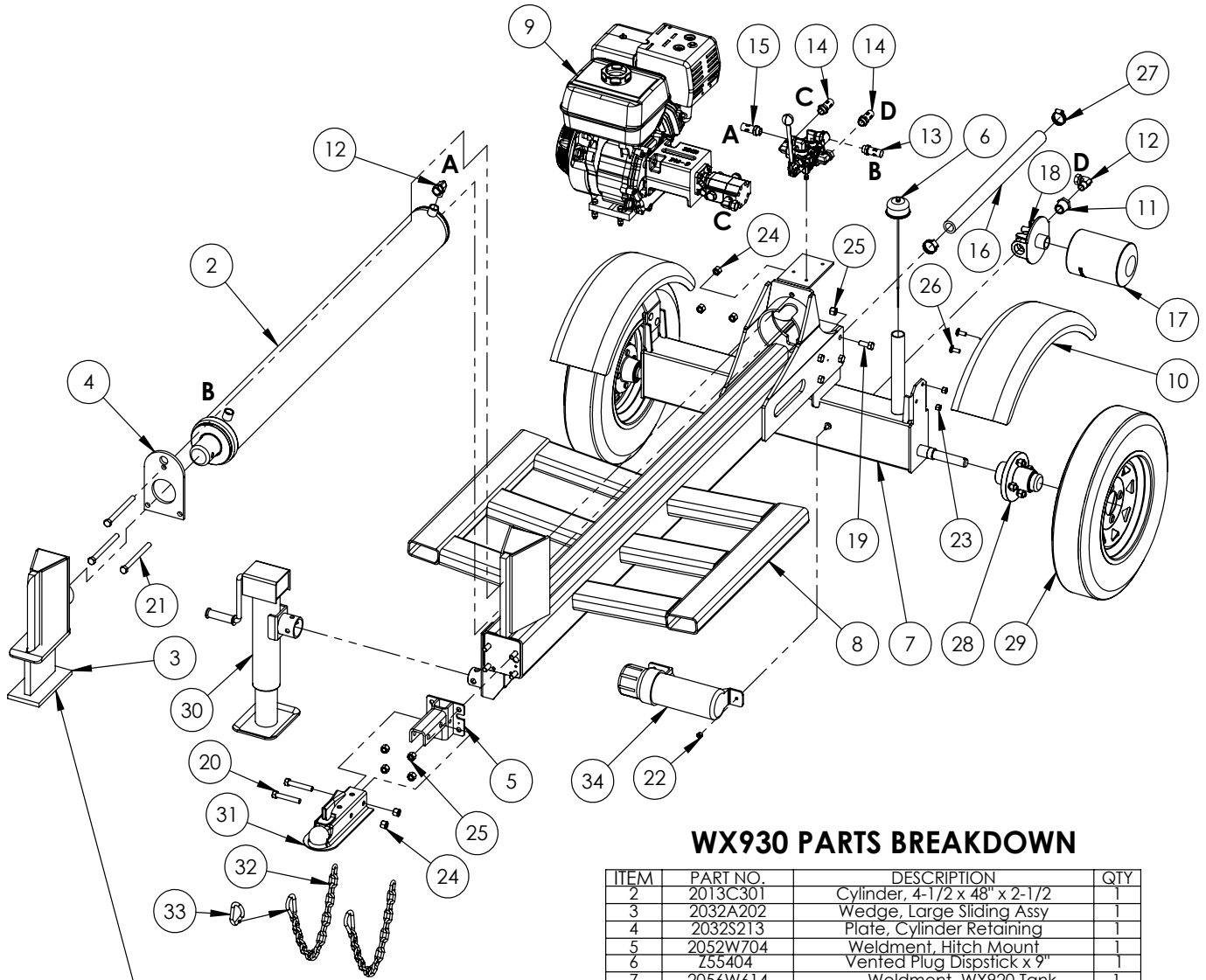

WX930 PARTS BREAKDOWN

ITEM	PART NO.	DESCRIPTION	QTY
2	2013C301	Cylinder, 4-1/2 x 48" x 2-1/2	1
3	2032A202	Wedge, Large Sliding Assy	1
4	2032S213	Plate, Cylinder Retaining	1
5	2052W704	Weldment, Hitch Mount	1
6	Z55404	Vented Plug Dispstick x 9"	1
7	2056W614	Weldment, WX920 Tank	1
8	2057W710	Weldment, WX930 Cylinder	1
9	2061A103	Assy, 9hp Engine to 16gpm Pump	1
10	2061W103	Weldment, Fender	2
11	Z51223	Reducer, MP x FP 1608	1
12	Z51331	Elbow 90 MP x FPX 0808	2
13	Z52301	1/2 Hose MP08 x MP08 x 16"	1
14	Z52305	1/2 Hose, MP08 x MP08 x 24"	2
15	Z52310	1/2 Hose MP08 x MP08 x 48"	1
16	Z52405	Suction Hose, 1" x 22"	1
17	Z55303	Oil Filter - 1" - Particulate	1
18	Z55304	Filter Cap, FP16 x FP16	1
19	Z71512	Hex Bolt 1/2NC x 1-1/4	8
20	Z71530	Hex Bolt 1/2NC x 3	2
21	Z71560	Hex Bolt 1/2NC x 6	3
22	Z72221	Hex Lock Nut 5/16NC	1
23	Z72231	Hex Lock Nut 3/8NC	4
24	Z72251	Hex Lock Nut 1/2NC	5
25	Z72251	Hex Lock Nut 1/2NC	12
26	Z76231	Carriage Bolt 3/8NC x 1	4
27	Z79401	Hose Clamp, #16	2
28	Z91202	Assembly, 1000# 4-Bolt Hub	2
29	Z91302	5.30-12 LRB Sporttrail 4 Spoked	2
30	Z91512	Side-Wind 10" Swivel Jack	1
31	Z91614	2" Hitch Coupler	1
32	Z92303	Safety Chain 1/4 x 2'	2
33	Z92303-2	Safety Snap	2
34	Z96503	Manual Tube 3-1/2 Short	1
ITEM	PART NO.	DESCRIPTION	QTY
40	2014S414	Plate, Sliding Wedge Capture	-
41	2058W803	Wedge, Large Sliding	-
42	Z71540	Hex Bolt 1/2NC x 4	-
43	Z71576	Hex Bolt 1/2NF x 1-1/2	-
44	Z72251	Hex Lock Nut 1/2NC	-

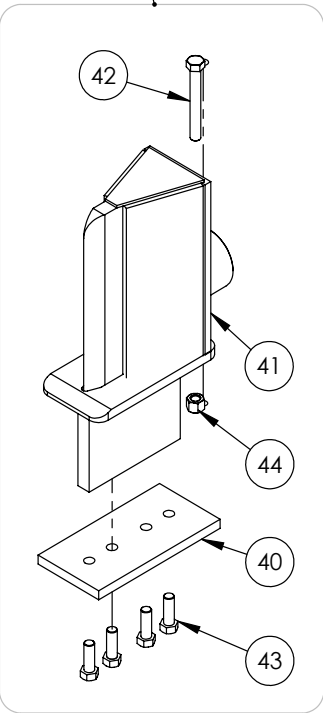

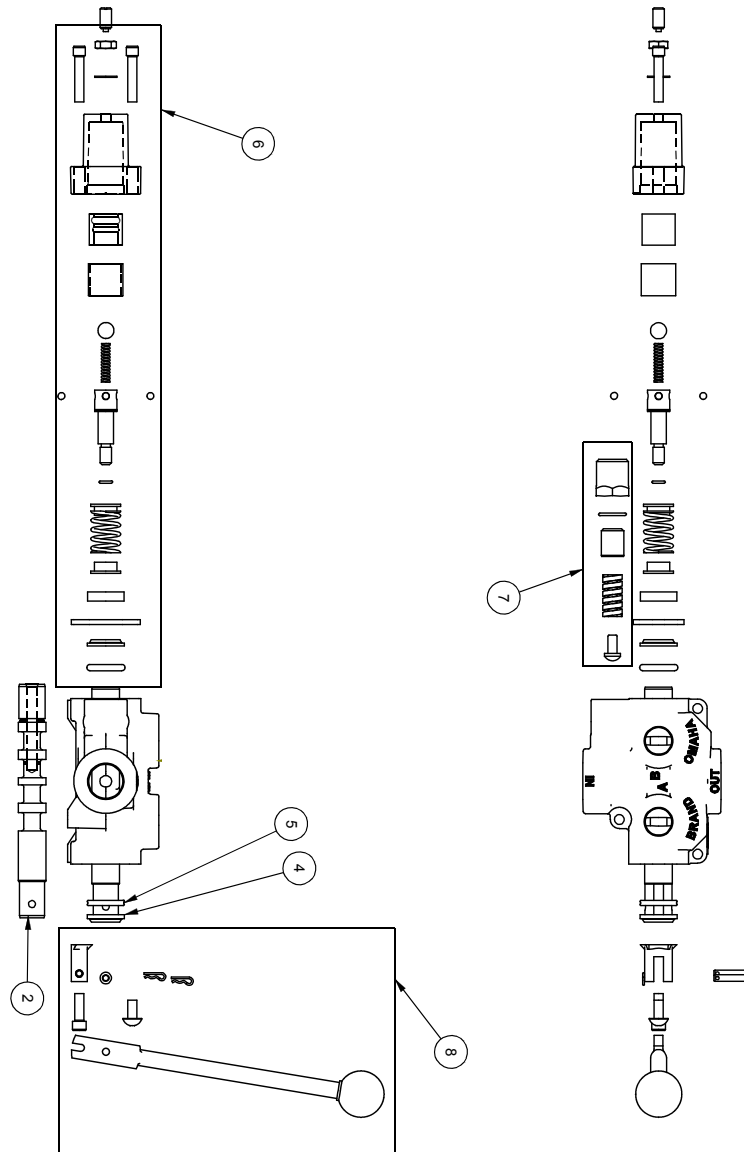

ITEM NO.	QTY.	PART NO.	DESCRIPTION
1	1	AOCASTB	AO CASTING
2	1	LS304TAJ	SPOOL
3	1	P1740	NAME TAG
4	1	SF305	WIPER
5	1	SF304	QUAD RING
6	1	SUB-LS	SUB-LS
	1	B5057	7/16 BALL
	4	DC7604	3/16 BALL
	1	SF306	RETAINER
	1	SF477L	SH LS ENDCAP
	1	XDC672	LS SLEEVE
	1	SF483	SPACER
	2	SF486	ALLEN SCREW
	2	SF489	CENTER STOP
	1	SF490	CENTERING SPRING
	1	SF492	HOUSING
	1	SF315	SPACER
	1	LS305	DETENT SPRING
	1	DC7583	O-RING 3-902
	1	SF496	O-RING BLUE METRIC
	1	LS306	LS WIPER
	1	SF502	5/16 LOCK WASHER
	1	SF503	PLUNGER SPRING
	1	SF504	5/16 HEX JAM NUT
7	1	SUB-R	RELIEF
	1	P1603	CAP NUT
	1	SF322	O-RING 2-016
	1	SF364A	ADJ. SCREW
	1	B505	SPRING
	1	SF361A	POPPET
8	1	Z56915	HANDLE KIT
	1	SF377	RETAINER
	1	SF376	SEAL RETAINER
	1	SF367A	CLEVIS
	1	SF368	HANDLE
	2	SF369	PIN
	2	P1767	PIN CLIP
	1	HR5	MACH. SCREW
	1	SF311	KNOB
	1	SF308	CAP SCREW
	1	SF303TAJ	SPOOL
9	1	P1654	WARNING TAG

ITEM NO.	QTY.	PART NO.	DESCRIPTION
1	1	B5057	7/16 BALL
2	4	DC7604	3/16 BALL
3	1	SF306	RETAINER
4	1	SF477L	SH LS ENDCAP
5	1	SF480	SD SLEEVE
6	1	SF483	SPACER
7	2	SF486	ALLEN SCREW
8	2	SF489	CENTER STOP
9	1	SF490	CENTERING SPRING
10	1	SF492	HOUSING
11	1	SF315	SPACER
12	1	LS305	DETENT SPRING
13	1	DC7583	O-RING 3-902
14	1	SF496	METRIC O-RING
15	1	LS306	LS WIPER
16	1	SF502	5/16 LOCK WASHER
17	1	SF503	SPRING PLUNGER
18	1	SF504	5/16 HEX JAM NUT

Note: This diagram is for reference only. Parts not sold separately.

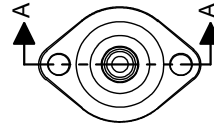
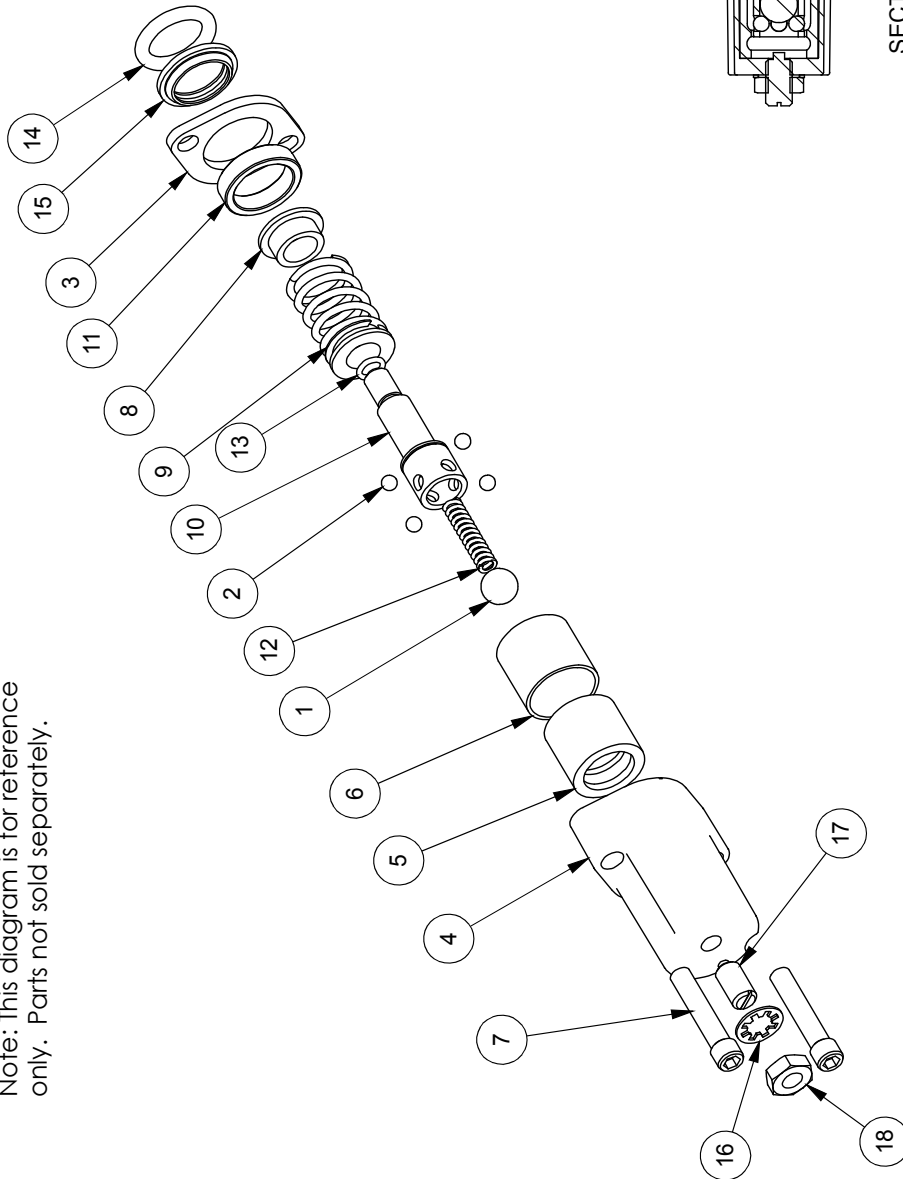

SECTION A-A

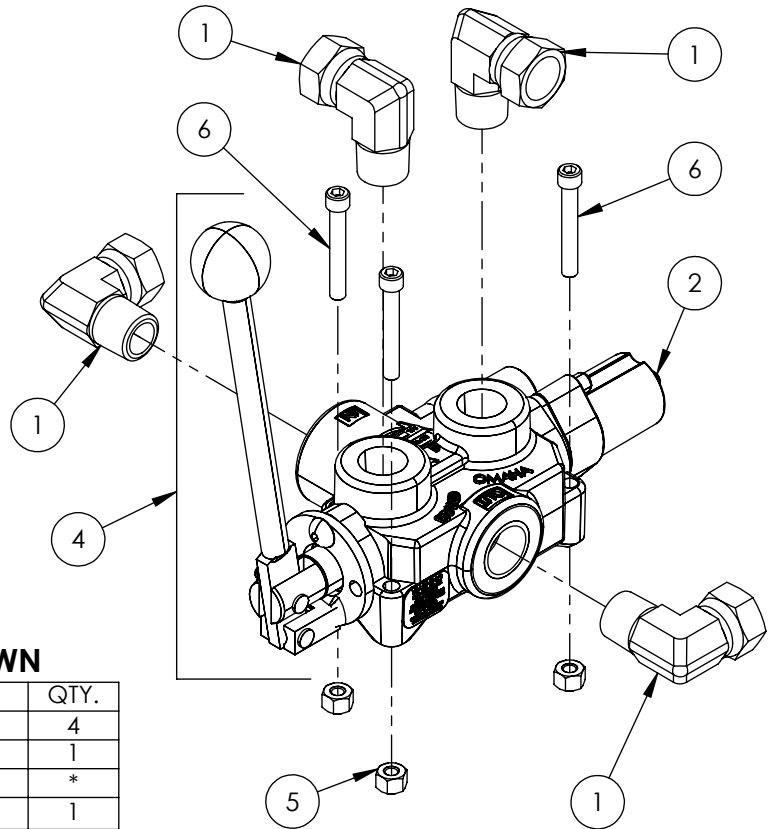

VALVE AND FITTINGS PARTS BREAKDOWN

ITEM	PART NO.	Description	QTY.
1	Z51331	Elbow 90 MP x FPX 0808	4
2	Z56209	Valve, Single Function Detent	1
3	*Z56210*	Valve, Closed Center	*
4	Z56915	Complete Handle Kit for Z56209	1
5	Z72111	Hex Lock Nut 1/4NC	3
6	Z75114	SHCS, 1/4NC x 1-3/4	3

CLOSED CENTER VALVE REQUIRED FOR "C" MODELS.

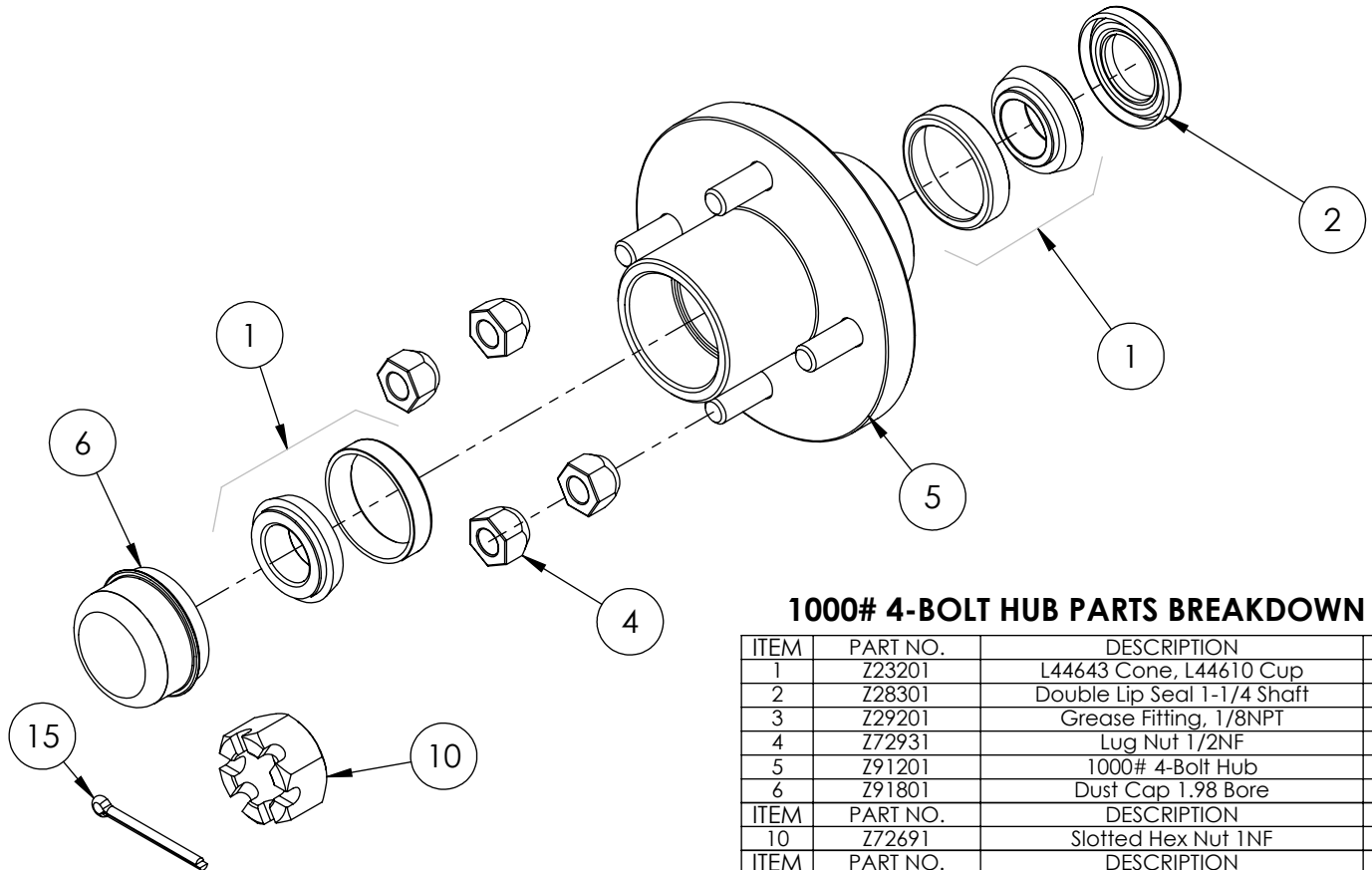

1000# 4-BOLT HUB PARTS BREAKDOWN

ITEM	PART NO.	DESCRIPTION	QTY
1	Z23201	L44643 Cone, L44610 Cup	2
2	Z28301	Double Lip Seal 1-1/4 Shaft	1
3	Z29201	Grease Fitting, 1/8NPT	1
4	Z72931	Lug Nut 1/2NF	4
5	Z91201	1000# 4-Bolt Hub	1
6	Z91801	Dust Cap 1.98 Bore	1
ITEM	PART NO.	DESCRIPTION	QTY
10	Z72691	Slotted Hex Nut 1NF	1
ITEM	PART NO.	DESCRIPTION	QTY
15	Z12322	Cotter Pin 3/16 X 2	1

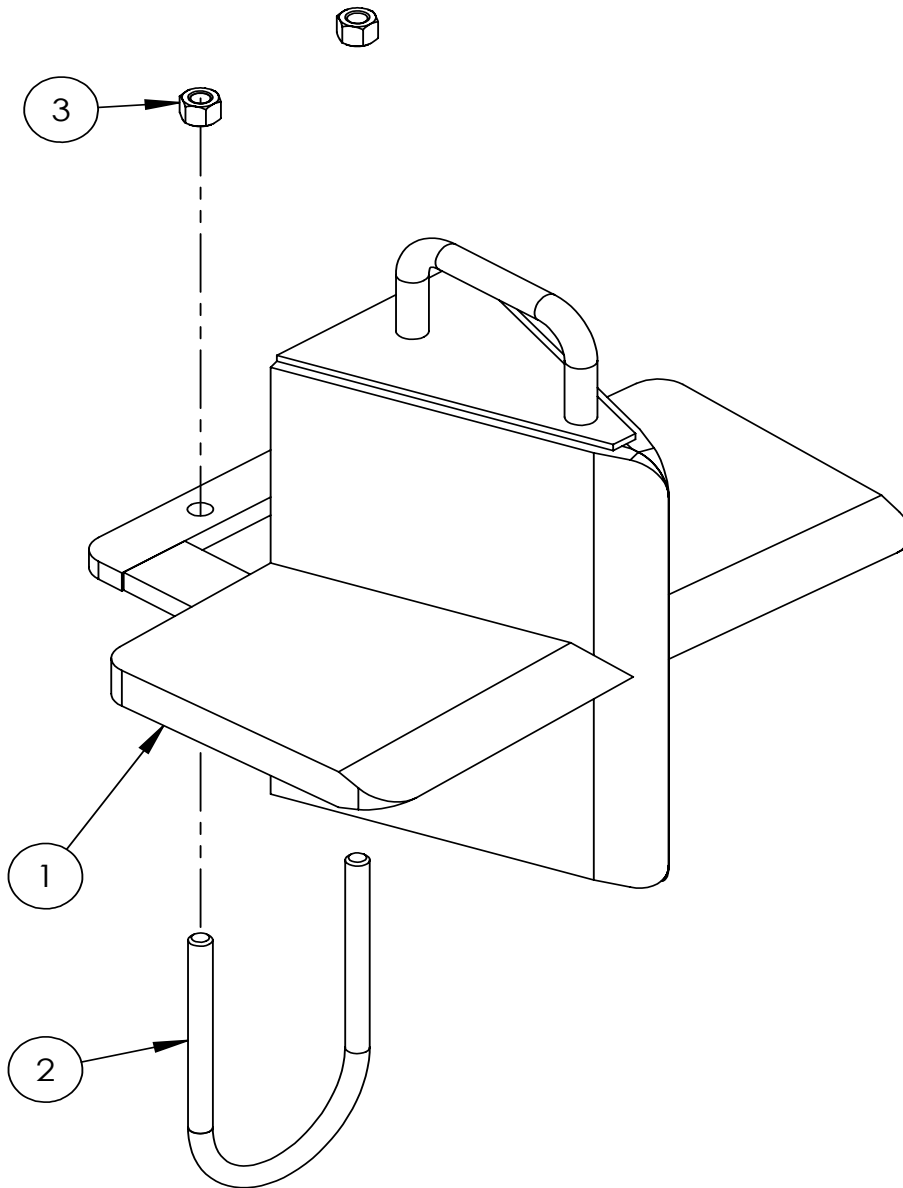

W4130 4-Way Wedge (Optional)

ITEM	PART NO.	DESCRIPTION	QTY
1	2082W301	Weldment, Main 4-Way	1
2	2082S307	U-Bolt, 3 x 4	1
3	Z72231	Hex Lock Nut 3/8NC	2

WX TRAILER SPLITTER WIRING

RIGHT SIDE

KEY	
Bl	- BLUE
Br	- BROWN
Gr	- GREEN
Rd	- RED
Yl	- YELLOW
Bk	- BLACK
Wh	- WHITE

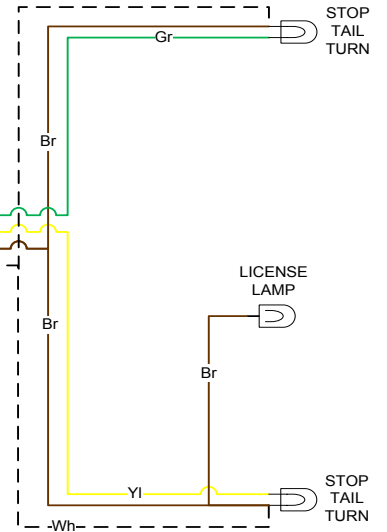
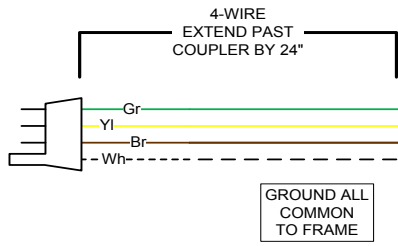

LEFT SIDE

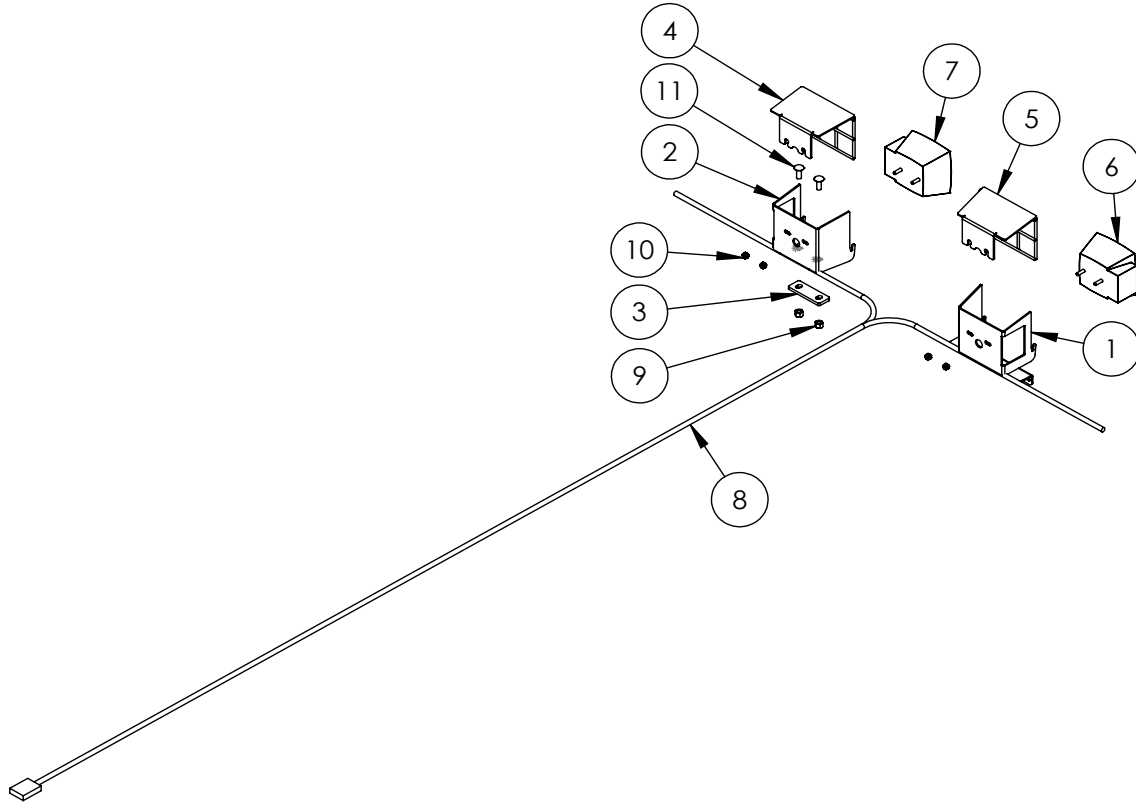

2089A350 LIGHT KIT (Optional)

ITEM	PART NO.	DESCRIPTION	QTY
1	2054L402	Light Bracket, LH	1
2	2054L601	Light Bracket, RH	1
3	2054L622	Bracket, Light Base	1
4	2054W403	Light Guard, RH	1
5	2054W404	Light Guard, LH	1
6	Z61106	Stop, Turn, Tail Light LH	1
7	Z61107	Stop, Turn, Tail Light RH	1
8	Z62105	110" Wishbone Trailer Harness	1
9	Z72231	Hex Lock Nut 3/8NC	2
10	Z72941	Serrated Washer Nut 1/4NC	4
11	Z76231	Carriage Bolt 3/8NC x 1	2

Decal Breakdown

TWO PANEL 920/930 SPLITTER DECAL BREAKDOWN

ITEM	PART NO.	DESCRIPTION	QTY
1	Z94119	CAUTION - Read Manual	1
2	Z94123	Keep Feet Clear	1
3	Z94067	Clear Guide	2
4	Z94056	Wallenstein	2
5	Z94019	Made in Canada	2
6	Z94142	99 dB Sound Level	1
7	Z94124	Keep Hands Clear	1

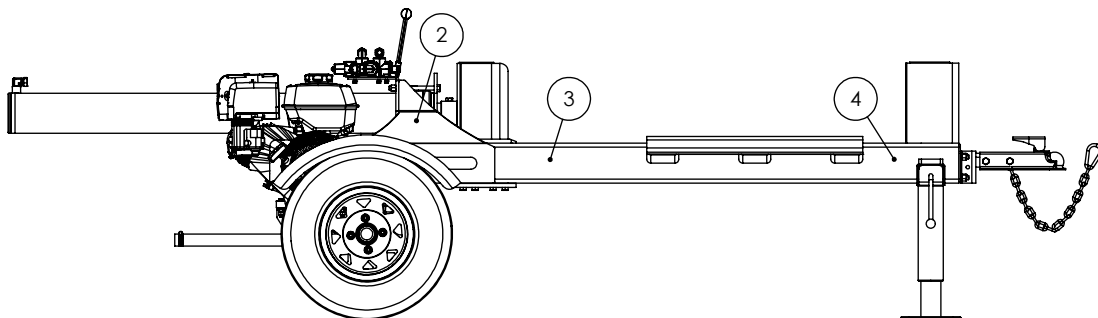
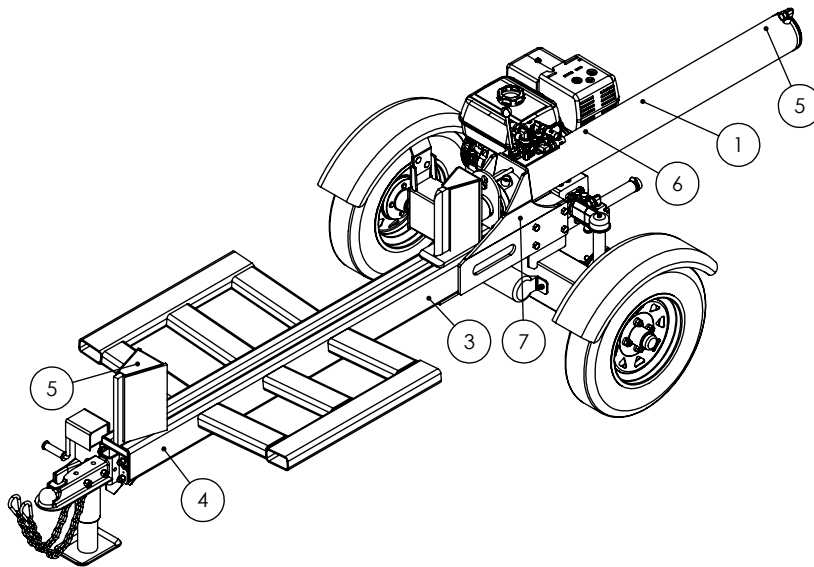

Two Panel Trailer Splitter Decals

Z94019



Z94142



Z94067

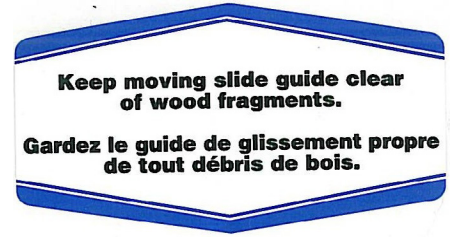

Z94056



Z94119



Z94123



Z94124





WALLENSTEIN Products Manufactured by:

EMB MFG Inc.

4144 Boomer Line
St. Clements, Ontario
Canada N0B 2M0
Phone: 1-877-695-9283
Fax: 519-699-4146
www.embmfg.com